



Pressure
vessels and
accessories



EUROTR**L**[®]
WATER TREATMENT COMPONENTS

MWG[®]
ITALIAN WATER TECHNOLOGY

Exclusive distributor worldwide

STRUCTURAL

MWG Residential Pressure Vessels with Base



- Made in China;
- Composite pressure vessels PE liner reinforced with fiberglass and epoxy resin;
- For industrial and potable water treatment systems;
- European 2014/68/EU Directive compliant for pressure equipment (PED);
- Certification for contact with drinking water following EC directives and KTW (for Germany) recommendations;
- D.M. n.174 dated 06/04/2004 compliant about materials suitable for contact with water for human consumption;
- In compliance with the sanitary certification ACS (France);
- Max operating pressure 10 bar; max operating temperature 50°C;
- Top connection threaded 2 ½" – 8NPSM or 4" – 8UN;
- Cycle test 250.000 times from 0,7 to 10 bar;
- Burst test to 4 times max operating pressure;
- Blue colour; warranty 10 years.

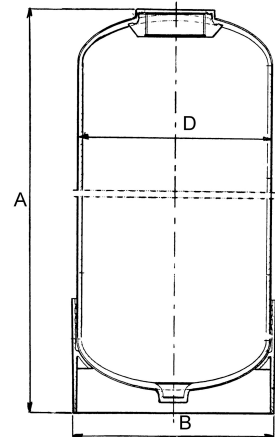

REF.	MODEL	VOLUME (liters)	EXTERNAL D (mm)	A (mm)	B (mm)	CONNECTION	
BMWG05013BB	5 x 13	3,2	130	335 ± 6	135	2 ½"	
BMWG06013BB	6 x 13	4,9	159	335 ± 6	165	2 ½"	
BMWG06018BB	6 x 18	7,2	159	462 ± 6	165	2 ½"	
BMWG06035BB	6 x 35	15,0	159	896 ± 6	165	2 ½"	
BMWG07013BB	7 x 13	6,3	180	333 ± 6	188	2 ½"	
BMWG07017BB	7 x 17	8,6	180	434 ± 6	188	2 ½"	
BMWG07024BB	7 x 24	13,2	180	605 ± 6	188	2 ½"	
BMWG07030BB	7 x 30	16,4	180	768 ± 6	188	2 ½"	
BMWG07035BB	7 x 35	20,1	180	891 ± 6	188	2 ½"	
BMWG08013BB	8 x 13	8,5	207	338 ± 6	216	2 ½"	
BMWG08017BB	8 x 17	10,9	207	439 ± 6	216	2 ½"	
BMWG08024BB	8 x 24	15,9	207	627 ± 6	216	2 ½"	
BMWG08030BB	8 x 30	20,9	207	773 ± 6	216	2 ½"	
BMWG08035BB	8 x 35	25,0	207	898 ± 6	216	2 ½"	
BMWG08044BB	8 x 44	32,6	207	1130 ± 6	216	2 ½"	
BMWG09017BB	9 x 17	13,8	231	456 ± 6	240	2 ½"	
BMWG09030BB	9 x 30	26,9	231	776 ± 6	240	2 ½"	
BMWG09035BB	9 x 35	32,1	231	900 ± 6	240	2 ½"	
BMWG09042BB	9 x 42	38,4	231	1076 ± 6	240	2 ½"	
BMWG09048BB	9 x 48	44,4	231	1227 ± 6	240	2 ½"	
BMWG10017BB	10 x 17	16,7	258	445 ± 6	266	2 ½"	
BMWG10019BB	10 x 19	19,3	258	482 ± 6	266	2 ½"	
BMWG10024BB	10 x 24	25,2	258	611 ± 6	266	2 ½"	
BMWG10030BB	10 x 30	33,0	258	780 ± 6	266	2 ½"	
BMWG10035BB	10 x 35	39,4	258	902 ± 6	266	2 ½"	
BMWG10044BB	10 x 44	51,0	258	1132 ± 6	266	2 ½"	
BMWG10047BB	10 x 47	54,1	258	1197 ± 6	266	2 ½"	
BMWG10054BB	10 x 54	63,5	258	1391 ± 6	266	2 ½"	
BMWG10054GB	10 x 54	63,5	258	1390 ± 6	266	4"	
BMWG12048BB	12 x 48	78,9	308	1234 ± 6	318	2 ½"	
BMWG12052BB	12 x 52	85,9	308	1334 ± 6	318	2 ½"	
BMWG13044BB	13 x 44	83,1	335	1118 ± 6	343	2 ½"	
BMWG13054BB	13 x 54	104,3	335	1375 ± 6	343	2 ½"	
BMWG13054GB	13 x 54	104,3	335	1375 ± 6	343	4"	

Structural Residential Pressure Vessels with Base



- Made in European Union (Belgium);
- Composite pressure vessels PE liner reinforced with fiberglass and epoxy resin;
- For industrial and potable water treatment systems;
- European 2014/68/EU Directive compliant for pressure equipment (PED);
- Certification for contact with drinking water following EC directives and KTW (for Germany) recommendations;
- D.M. n.174 dated 06/04/2004 compliant about materials suitable for contact with water for human consumption;
- In compliance with the sanitary certification ACS (France);
- Max operating pressure 10 bar;
- Max operating temperature 50°C;
- Top connection threaded 2 1/2" – 8NPSM or 4" – 8UN;
- Cycle test 250.000 times from 0,7 to 10 bar;
- Burst test to 4 times max operating pressure;
- Blue colour;
- Warranty 5 years.

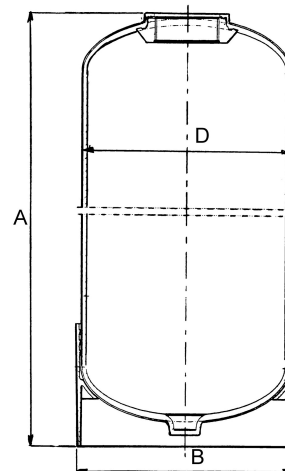

REF.	MODEL	VOLUME (liters)	EXTERNAL D (mm)	A (mm)	B (mm)	CONNECTION	
BSQ0613A3	6 x 13	4,6	159	342 ± 2	170	2 1/2"	
BSQ0618A3	6 x 18	6,9	159	475 ± 2	170	2 1/2"	
BSRT0635P3E	6 x 35	14,4	159	907 ± 2	170	2 1/2"	
BSQ0713A3	7 x 13	6,3	184	341 ± 2	195	2 1/2"	
BSQ0717A3	7 x 17	8,8	184	446 ± 2	195	2 1/2"	
BSRT0724A3E	7 x 24	13,5	184	613 ± 2	195	2 1/2"	
BSQ0730A3	7 x 30	16,8	184	778 ± 2	195	2 1/2"	
BSQ0735A3	7 x 35	20,4	184	901 ± 2	195	2 1/2"	
BSQ0817A3	8 x 17	11,0	208	435 ± 2	220	2 1/2"	
BSRT0824A3E	8 x 24	16,6	208	612 ± 4	220	2 1/2"	
BSQ0830A3	8 x 30	22,0	208	783 ± 2	220	2 1/2"	
BSQ0835A3	8 x 35	25,7	208	902 ± 2	220	2 1/2"	
BSQ0844P3	8 x 44	33,6	208	1124 ± 2	220	2 1/2"	
BSRT0917A3E	9 x 17	13,7	233	431 ± 4	240	2 1/2"	
BSRT0930A3E	9 x 30	26,6	233	766 ± 5	240	2 1/2"	
BSQ0935A3	9 x 35	31,3	233	903 ± 2	240	2 1/2"	
BSRT0942A3E	9 x 42	38,2	233	1074 ± 5	240	2 1/2"	
BSRT0948A3E	9 x 48	44,6	233	1228 ± 5	240	2 1/2"	
BSRT1017A3E	10 x 17	16,8	257	436 ± 4	269	2 1/2"	
BSQ1019A3	10 x 19	19,1	257	502 ± 2	269	2 1/2"	
BSRT1022A3E	10 x 22	22,9	257	559 ± 4	269	2 1/2"	
BSRT1024A3E	10 x 24	25,1	257	605 ± 4	269	2 1/2"	
BSRT1030A3E	10 x 30	32,4	257	766 ± 4	269	2 1/2"	
BSQ1035A3	10 x 35	38,9	257	903 ± 2	269	2 1/2"	
BSQ1044P3	10 x 44	48	257	1122 ± 2	269	2 1/2"	
BSRT1047P3E	10 x 47	54	257	1188 ± 5	269	2 1/2"	
BSQ1054P3	10 x 54	61	257	1385 ± 2	269	2 1/2"	
BSRT1055P3EN	10 x 55	62	257	1382 ± 5	269	4"	
BSQ1248P3	12 x 48	76	304	1232 ± 3	315	2 1/2"	
BSQ1252P3	12 x 52	84	304	1335 ± 3	315	2 1/2"	
BSRT1344A3E	13 x 44	85	334	1145 ± 6	330	2 1/2"	
BSQ1354A3	13 x 54	103	334	1371 ± 3	330	2 1/2"	
BSRT1355A3EN	13 x 55	103	334	1371 ± 3	330	4"	

MWG Residential Pressure Vessels without Base



- Made in China;
- Composite pressure vessels PE liner reinforced with fiberglass and epoxy resin;
- For industrial and potable water treatment systems;
- European 2014/68/EU Directive compliant for pressure equipment (PED);
- Certification for contact with drinking water following EC directives and KTW (for Germany) recommendations;
- D.M. n.174 dated 06/04/2004 compliant about materials suitable for contact with water for human consumption;
- In compliance with the sanitary certification ACS (France);
- Max operating pressure 10 bar;
- Max operating temperature 50°C;
- Top connection threaded 2 ½" – 8NPSM or 4"– 8UN;
- Cycle test 250.000 times from 0,7 to 10 bar;
- Burst test to 4 times max operating pressure;
- Blue colour;
- Warranty 10 years.

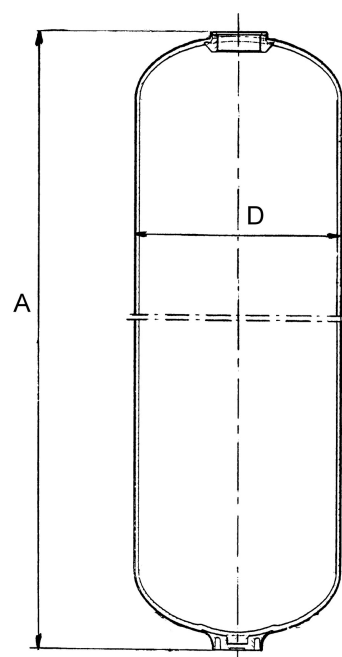

REF.	MODEL	VOLUME (liters)	EXTERNAL D (mm)	A (mm)	CONNECTION (inch)	
BMWG05013AB	5 x 13	3,1	129	329 ± 3	2 ½"	
BMWG06013AB	6 x 13	4,7	159,5	329 ± 3	2 ½"	
BMWG07013AB	7 x 13	5,9	180	329 ± 3	2 ½"	
BMWG07017AB	7 x 17	8,2	180	431 ± 3	2 ½"	
BMWG07019AB	7 x 19	9,4	180	483 ± 3	2 ½"	
BMWG07024AB	7 x 24	12,4	180	611 ± 3	2 ½"	
BMWG07030AB	7 x 30	16,01	180	771 ± 3	2 ½"	
BMWG07035AB	7 x 35	18,09	180	891 ± 3	2 ½"	
BMWG08013AB	8 x 13	7,6	207	329 ± 3	2 ½"	
BMWG08017AB	8 x 17	10,7	207	431 ± 3	2 ½"	
BMWG08024AB	8 x 24	16,03	207	611 ± 3	2 ½"	
BMWG08030AB	8 x 30	21,2	207	771 ± 3	2 ½"	
BMWG08035AB	8 x 35	25,0	207	891 ± 3	2 ½"	
BMWG09017AB	9 x 17	13,3	230	431 ± 3	2 ½"	
BMWG09024AB	9 x 24	20,3	230	611 ± 3	2 ½"	
BMWG09030AB	9 x 30	26,5	230	771 ± 3	2 ½"	
BMWG09035AB	9 x 35	31,1	230	891 ± 3	2 ½"	
BMWG10017AB	10 x 17	16,4	257,5	431 ± 3	2 ½"	
BMWG10019AB	10 x 19	19,0	257,5	483 ± 3	2 ½"	
BMWG10024AB	10 x 24	25,2	257,5	611 ± 3	2 ½"	
BMWG10030AB	10 x 30	33,0	257,5	771 ± 3	2 ½"	
BMWG10035AB	10 x 35	38,8	257,5	891 ± 3	2 ½"	

Structural Dome-Hole Residential Pressure Vessels



- Made in U.S.A.;
- Composite pressure vessels PE liner reinforced with fiberglass and epoxy resin;
- 1 ¼" opening on the dome top of the tank with Noryl plug;
- For industrial and potable water treatment systems;
- European 2014/68/EU Directive compliant for pressure equipment (PED);
- Certification for contact with drinking water following EC directives and KTW (for Germany) recommendations;
- Max operating pressure 10 bar;
- Max operating temperature 50°C;
- Top connection threaded 2 ½" – 8NPSM;
- Cycle test 250.000 times from 0,7 to 10 bar;
- Burst test to 4 times max operating pressure;
- Natural colour;
- Warranty 5 years.

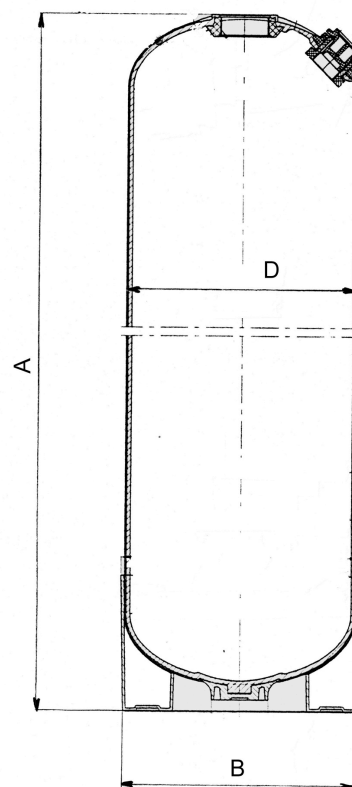

REF.	MODEL	VOLUME (liters)	EXTERNAL D (mm)	A (mm)	B (mm)	CONNECTION (inch)	
B10044QN(*)	10 x 44 DH	48	257	1122	269	2 ½"	
B10054QN(*)	10 x 54 DH	61	257	1378	269	2 ½"	
B12052QN(*)	12 x 52 DH	84	306	1346	312	2 ½"	
B13054QN(*)	13 x 54 DH	103	364	1370	375	2 ½"	

(*) not available in stock.

MWG Industrial Pressure Vessels With Threaded Top Opening



- Made in China;
- Composite pressure vessels PE liner reinforced with fiberglass and epoxy resin;
- For industrial and potable water treatment systems;
- European 2014/68/EU Directive compliant for pressure equipment (PED);
- Certification for contact with drinking water following EC directives and KTW (for Germany) recommendations;
- D.M. n.174 dated 06/04/2004 compliant about materials suitable for contact with water for human consumption;
- In compliance with the sanitary certification ACS (France);
- Max operating pressure 10 bar;
- Max operating temperature 50°C;
- Threaded top connection 4"– 8UN;
- Cycle test 250.000 times from 0,7 to 10 bar;
- Burst test to 4 times max operating pressure;
- Blue colour;
- Warranty 5 years.

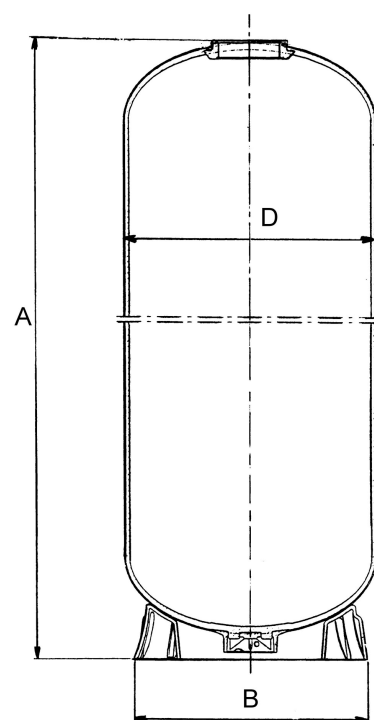

REF.	MODEL	VOLUME (liters)	EXTERNAL DIAMETER (mm)	A (mm)	B (mm)	CONNECTION (inch)	
BMWG14052GB	14 x 52	115,4	360	1325 ± 6	369	4" (**)	
BMWG14065GB	14 x 65	147	360	1655 ± 6	369	4" (**)	
BMWG16052GB	16 x 52	150,0	410	1316 ± 6	420	4" (**)	
BMWG16065GB	16 x 65	191,3	410	1648 ± 6	420	4" (**)	
BMWG18053GB	18 x 53	193,6	464	1366 ± 6	451	4"	
BMWG18065GB	18 x 65	242,3	464	1670 ± 6	451	4"	
BMWG21036GB	21 x 36	168,2	541	958 ± 10	532	4"	
BMWG21053GB	21 x 53	262,4	541	1390 ± 10	532	4"	
BMWG21062GB	21 x 62	312,7	541	1620 ± 10	532	4"	
BMWG24065GB	24 x 65	426,5	615	1730 ± 10	612	4"	
BMWG24072GB	24 x 72	477,5	615	1910 ± 10	612	4"	
BMWG30072GB (*)	30 x 72	725,9	767	1890 ± 10	752	4"	
BMWG36072GB (*)	36 x 72	1030,2	919	1965 ± 10	910	4"	

(*) Vacuum breaker included.

(**) with reduction 2,5"

Structural Industrial Pressure Vessels With Threaded Top Opening



- Made in European Union (Belgium);
- composite pressure vessels PE liner reinforced with fiberglass and epoxy resin;
- for industrial and potable water treatment systems;
- European 2014/68/EU Directive compliant for pressure equipment (PED);
- Certification for contact with drinking water following EC directives and KTW (for Germany) recommendations;
- D.M. n.174 dated 06/04/2004 compliant about materials suitable for contact with water for human consumption;
- In compliance with the sanitary certification ACS (France);
- Max operating pressure 10 bar;
- max operating temperature 50°C;
- threaded top connection 4"– 8UN;
- cycle test 250.000 times from 0,7 to 10 bar;
- burst test to 4 times max operating pressure;
- blue colour;
- Warranty 5 years.

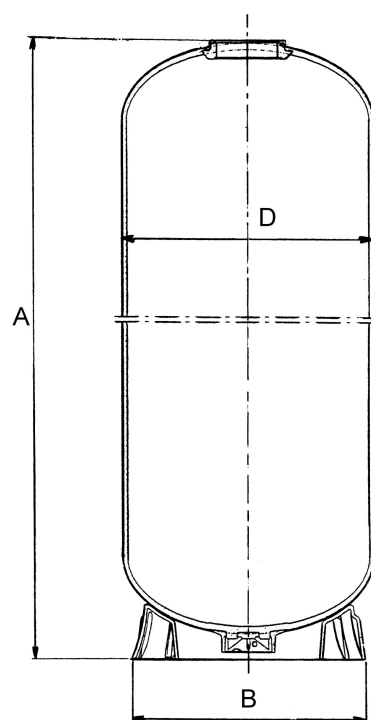

REF.	MODEL	VOLUME (liters)	EXTERNAL DIAMETER (mm)	A (mm)	B (mm)	CONNECTION (inch)	
BSRT1452A3REN	14 x 52	122	369	1360 ± 20	330	4" (**)	
BSRT1465A3REN	14 x 65	140	369	1645 ± 20	380	4" (**)	
BSRT1649A3REN	16 x 49	125	406	1269 ± 20	420	4" (**)	
BSRT1665A3REN	16 x 65	170	406	1632 ± 20	420	4" (**)	
BSRT1856A3E	18 x 56	211	469	1432 ± 20	510	4"	
BSRT1865A3EN	18 x 65	250	469	1726 ± 20	510	4"	
BSRT2153A3E	21 x 53	277	552	1434 ± 20	510	4"	
BSRT2160A3E	21 x 60	310	552	1625 ± 20	510	4"	
BSRT2469A3E	24 x 69	440	610	1870 ± 20	510	4"	
BSRT3072A3E (*)	30 x 72	710	770	2030 ± 30	730	4"	
BSRT3672A3E (*)	36 x 72	1020	930	2130 ± 30	730	4"	

(*) Vacuum breaker included.

(**) with reduction 2,5"

MWG Industrial Pressure Vessels With Top&Bottom Threaded Openings



- Made in China;
- Composite pressure vessels PE liner reinforced with fiberglass and epoxy resin;
- For industrial and potable water treatment systems;
- European 2014/68/EU Directive compliant for pressure equipment (PED);
- Certification for contact with drinking water following EC directives and KTW (for Germany) recommendations;
- D.M. n.174 dated 06/04/2004 compliant about materials suitable for contact with water for human consumption;
- In compliance with the sanitary certification ACS (France);
- Max operating pressure 10 bar;
- Max operating temperature 50°C;
- Top and bottom threaded connection 4" – 8UN;
- Cycle test 250.000 times from 0,7 to 10 bar;
- Burst test to 4 times max operating pressure;
- Blue colour;
- Warranty 5 years.

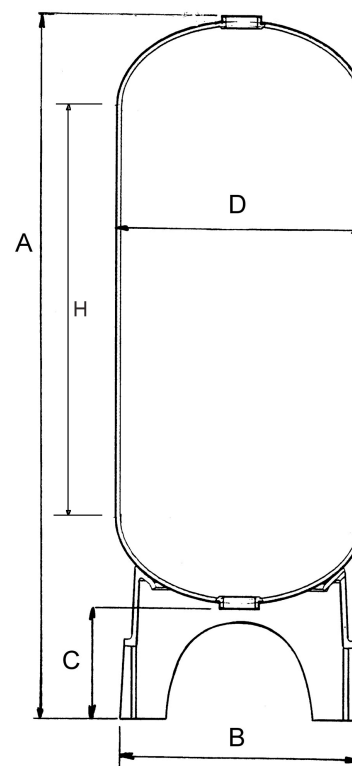

REF.	MODEL	VOLUME (liters)	EXTERNAL DIAMETER (mm)	A (mm)	B (mm)	C (mm)	H (mm)	CONNECTION (inch)	
BMWG14065HB	14 x 65	147,0	360	1856 ± 6	369	230	1386	4"	
BMWG16065HB	16 x 65	191,3	410	1880 ± 6	430	250	1365	4"	
BMWG18065HB	18 x 65	242,3	464	1950 ± 10	480	320	1330	4"	
BMWG21062HB	21 x 62	312,7	541	1902 ± 10	555	330	1220	4"	
BMWG24065HB	24 x 65	426,5	615	1916 ± 10	610	246	1220	4"	
BMWG24072HB	24 x 72	477,5	615	2095 ± 10	610	240	1400	4"	
BMWG30072HB (*)	30 x 72	726	750	2075 ± 10	762	235	1270	4"	
BMWG36072HB (*)	36 x 72	1030,2	922	2190 ± 10	930	350	1170	4"	

(*) Vacuum breaker included.

Structural Industrial Pressure Vessels With Top&Bottom Threaded Openings



- Made in European Union (Belgium);
- Composite pressure vessels PE liner reinforced with fiberglass and epoxy resin;
- For industrial and potable water treatment systems;
- European 2014/68/EU Directive compliant for pressure equipment (PED);
- Certification for contact with drinking water following EC directives and KTW (for Germany) recommendations;
- D.M. n.174 dated 06/04/2004 compliant about materials suitable for contact with water for human consumption;
- In compliance with the sanitary certification ACS (France);
- Max operating pressure 10 bar;
- Max operating temperature 50°C;
- Top and bottom threaded connection 4"– 8UN;
- Cycle test 250.000 times from 0,7 to 10 bar;
- Burst test to 4 times max operating pressure;
- Blue colour;
- Warranty 5 years.

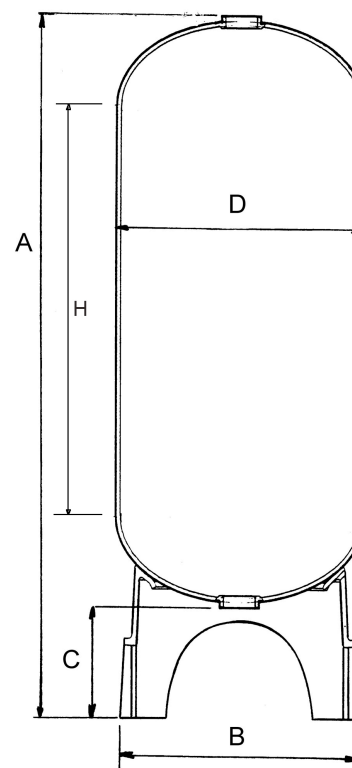

REF.	MODEL	VOLUME (liters)	EXTERNAL DIAMETER (mm)	A (mm)	B (mm)	C (mm)	H (mm)	CONNECTION (inch)	
BSRT1465F7E	14 x 65	140	369	2031 ± 20	488	381	1378	4"	
BSRT1665F7E	16 x 65	170	406	2031 ± 20	497	384	1371	4"	
BSRT1865F7E	18 x 65	250	469	2080 ± 20	554	404	1350	4"	
BSRT2160F7E	21 x 60	310	552	1923 ± 20	554	389	1155	4"	
BSRT2469F7E	24 x 69	440	610	2169 ± 20	620	422	1327	4"	
BSRT3072F7E (*)	30 x 72	710	770	2248 ± 30	816	413	1313	4"	
BSRT3672F7E (*)	36 x 72	1020	927	2305 ± 30	1001	408	1266	4"	

(*) Vacuum breaker included.

Structural Industrial Pressure Vessels With Flanged Top Opening



- Made in European Union (Belgium);
- Composite pressure vessels PE liner reinforced with fiberglass and epoxy resin;
- For industrial and potable water treatment systems;
- European 2014/68/EU Directive compliant for pressure equipment (PED);
- Certification for contact with drinking water following EC directives and KTW (for Germany) recommendations;
- D.M. n.174 dated 06/04/2004 compliant about materials suitable for contact with water for human consumption;
- In compliance with the sanitary certification ACS (France);
- Max operating pressure 10 bar;
- Max operating temperature 65°C;
- 6" top connection;
- Cycle test 250.000 times from 0,7 to 10 bar;
- Burst test to 4 times max operating pressure;
- Blue colour;
- Warranty 5 years.

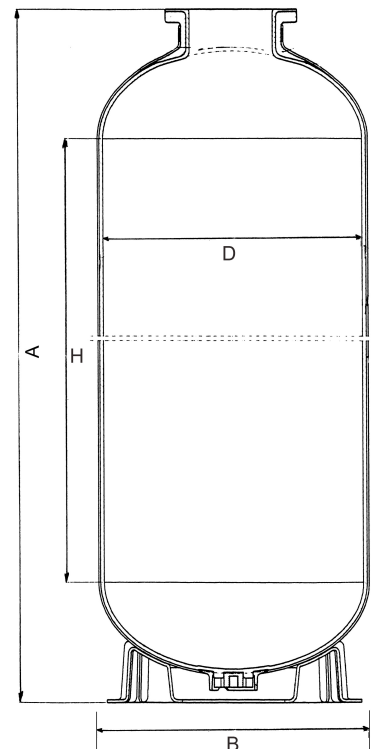

Flanged top opening detail
(dimensions in mm)

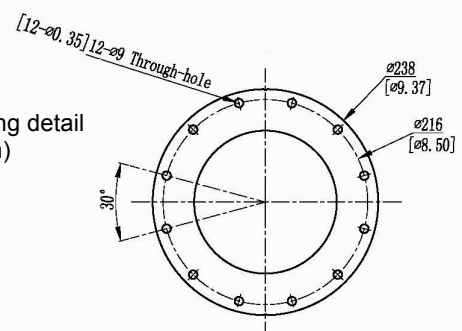

REF.	MODEL	VOLUME (liters)	EXTERNAL DIAMETER (mm)	A (mm)	B (mm)	H (mm)	CONNECTION (inch)	
BSRT1868A3E	18 x 68	250	469	1777 ± 20	510	1344	6"	
BSRT2166A3E	21 x 66	310	552	1673 ± 20	510	1159	6"	
BSRT2475A3E	24 x 75	450	610	1908 ± 20	510	1320	6"	
BSRT3078A3E (*)	30 x 78	710	770	2058 ± 30	768	1282	6"	
BSRT3678A3E (*)	36 x 78	1020	927	2155 ± 30	768	1235	6"	

(*) Vacuum breaker included.

MWG Industrial Pressure Vessels With Flanged Top&Bottom Openings



- Made in China;
- Composite pressure vessels PE liner reinforced with fiberglass and epoxy resin;
- For industrial and potable water treatment systems;
- European 2014/68/EU Directive compliant for pressure equipment (PED);
- Certification for contact with drinking water following EC directives and KTW (for Germany) recommendations;
- D.M. n.174 dated 06/04/2004 compliant about materials suitable for contact with water for human consumption;
- In compliance with the sanitary certification ACS (France);
- Max operating pressure 10 bar;
- Max operating temperature 65°C;
- Top and bottom 6" flange connection;
- Cycle test 250.000 times from 0,7 to 10 bar;
- Burst test to 4 times max operating pressure;
- Blue colour;
- Warranty 5 years.

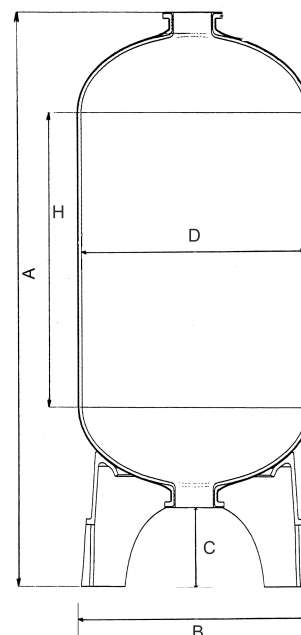

Flanged top opening detail
(dimensions in mm)

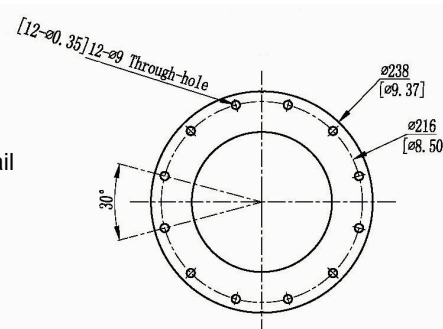

(*) Vacuum breaker included.

REF.	MODEL	VOLUME (liters)	EXTERNAL DIAMETER (mm)	A (mm)	B (mm)	C (mm)	H (mm)	CONN. (inch)	
BMWG30072MB (*)	30 x 72	736	772	2245 ± 25	815	265	1260	6"	
BMWG36072MB (*)	36 x 72	1045	925	2270 ± 25	920	285	1195	6"	
BMWG42063MB (*)	42 x 63	1235	1085	2055 ± 25	1070	270	955	6"	
BMWG42072MB (*)	42 x 72	1437	1085	2290 ± 25	1070	275	1185	6"	
BMWG48072MB (*)	48 x 72	1784	1218	2275 ± 25	1230	260	1110	6"	
BMWG63067MB (*)	63 x 67	2630	1608	2050 ± 25	1620	260	660	6"	
BMWG63086MB (*)	63 x 86	3425	1608	2460 ± 25	1620	260	1100	6"	

ATTENTION: for 63" pressure vessels, when you use a DN100 lower system, you have to raise the pressure vessel.

Structural Industrial Pressure Vessels With Flanged Top&Bottom Openings



- Made in European Union (Belgium);
- Composite pressure vessels PE liner reinforced with fiberglass and epoxy resin;
- For industrial and potable water treatment systems;
- European 2014/68/EU Directive compliant for pressure equipment (PED);
- Certification for contact with drinking water following EC directives and KTW (for Germany) recommendations;
- D.M. n.174 dated 06/04/2004 compliant about materials suitable for contact with water for human consumption;
- In compliance with the sanitary certification ACS (France);
- Max operating pressure 10 bar;
- Max operating temperature 65°C;
- Top and bottom 6" flange connection;
- Cycle test 250.000 times from 0,7 to 10 bar;
- Burst test to 4 times max operating pressure;
- Blue colour;
- Warranty 5 years.

(*) Vacuum breaker included.

(**) not available in stock.

Flanged top opening detail
(dimensions in mm)

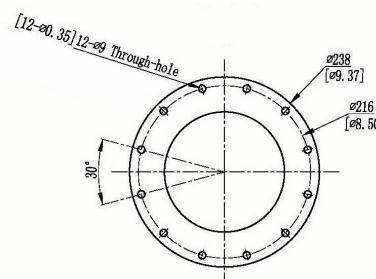
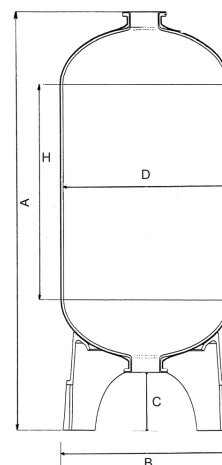

REF.	MODEL	VOLUME (liters)	EXTERNAL DIAMETER (mm)	A (mm)	B (mm)	C (mm)	H (mm)	CONN. (inch)	
BSC1868F7	18 x 68	250	469	2120 ± 20	545	340	1344	6"	
BSC2166F7	21 x 66	310	552	2010 ± 20	545	368	1158	6"	
BSC2475F7	24 x 75	450	610	2220 ± 20	620	354	1320	6"	
BSC3078F7 (*)	30 x 78	710	770	2285 ± 30	778	365	1284	6"	
BSC3678F7 (*)	36 x 78	1020	927	2330 ± 30	955	355	1272	6"	
BSRT4264F7E (*)	42 x 64	1047	1074	2065 ± 30	1110	440	775	6"	
BSC4278F7 (*)	42 x 78	1360	1074	2402 ± 30	1110	395	1162	6"	
BSC4882F7 (*)	48 x 82	1840	1226	2442 ± 30	1270	387	1075	6"	
BSC55104F7 (*) (**)	55 x 104	2619	1429	2661 ± 30	1370	539	1106	6"	
BSC55120F7 (*) (**)	55 x 120	3220	1429	3061 ± 30	1370	545	1500	6"	
BSC55130F7 (*) (**)	55 x 130	3602	1429	3311 ± 30	1370	545	1750	6"	
BSC55140F7 (*) (**)	55 x 140	3984	1429	3561 ± 30	1370	545	2000	6"	
BSRT6367F7E (*)	63 x 67	2484	1623	2075 ± 30	1570	355	594	6"	
BSRT6386F7E (*)	63 x 86	3200	1623	2475 ± 30	1570	355	996	6"	
BSC63103F7 (*) (**)	63 x 103	4265	1623	3250 ± 30	1570	627	1500	6"	
BSC63113F7 (*) (**)	63 x 113	4760	1623	3500 ± 30	1570	627	1750	6"	
BSC63123F7 (*) (**)	63 x 123	5255	1623	3750 ± 30	1570	627	2000	6"	



Adapters

- adapter 4" – 8UN to 2 1/2" – 8NPSM;
- with O-ring.

REF.	MODEL	REDUCTION TO	
PV300	PVC machined	2 1/2" – 8 NPSM	
PV307	PVC machined	2" BSP	

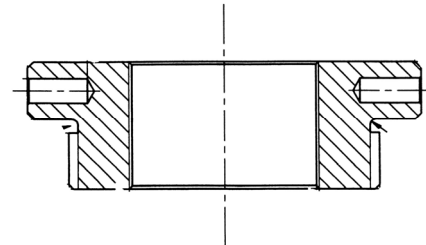

Closures

- closure for 4" – 8UN tanks thread;
- with O-ring.

REF.	MATERIAL	
PV301	PVC machined	

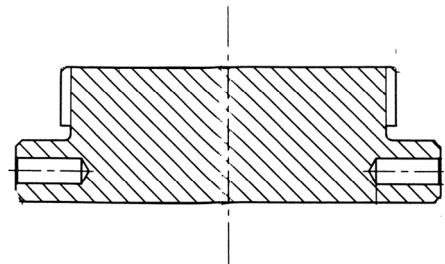

6" closed flange

- 6" closed flange complete with bolts, nuts, washer and O-ring;
- flange material PVC;
- bolts material AISI 304.

REF.	
PV510B	

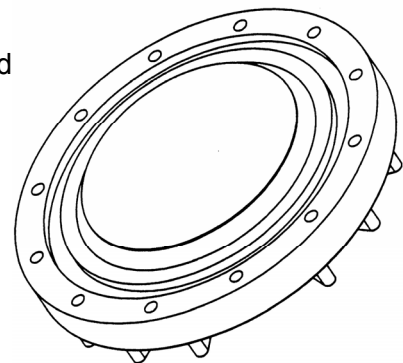



6" - 4" adapter

- 6" flanged adapter 4"-8UN, complete with bolts, nuts, washer and O-ring;
- bolts material AISI 304.

REF.	ADAPTER MATERIAL	
PV511B	PVC	

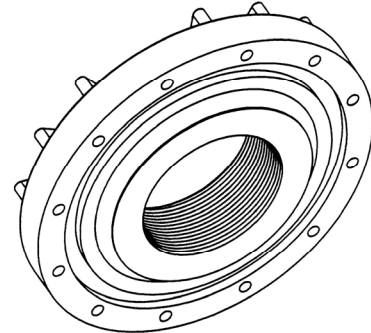

6" - 3" - 3" adapter

- 6" flanged x 3" x 3" BSP threaded adapter complete with bolts, nuts, washer and O-ring.;
- flange material PPO;
- bolts material AISI 304.

REF.	
PV509 (*)	

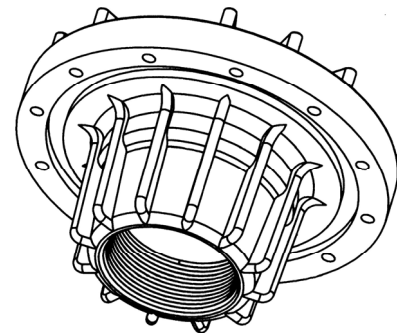

(*) available till it will be out-of-stock.

Aeration valve & vacuum breaker

- aeration valve and vacuum breaker in PP;
- connection 1 1/2", drain 1/2";
- max pressure 10 bar;
- max temperature 65°C.

REF.	
PV308	
PV308B	

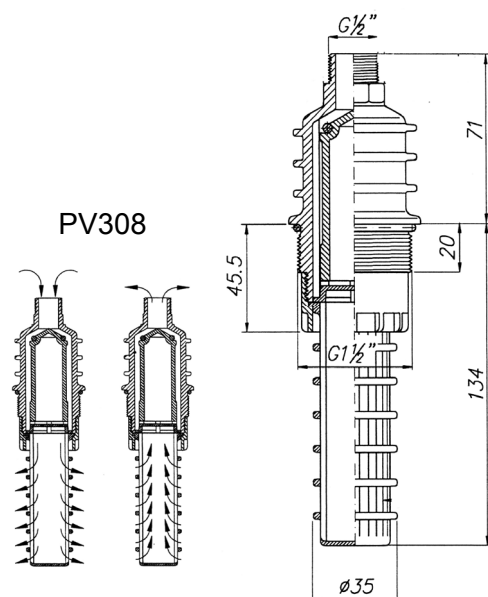



Cylindrical diffusors

- cylindrical diffuser for vessels with 4"- 8UN, for upper or lower installation;
- outlet connection to glue D.63;
- 0,2 mm slots or 0,5 mm;
- materials: adapter PVC, diffuser PP;
- flow 20 m³/h at Δp 0,2 bar;
 - A. union D63 (REF. PV329);
 - B. adapter 4" with gasket (REF. PV332);
 - C. reduction 2" M/F (REF. PV335);
 - D. diffuser diameter 85 mm length 180 mm.(REF. PV340 0,2 mm slots – REF. PV342 0,5 mm slots).

REF.	SLOTS (mm)	VESSEL	
PV351	0,2	14" ÷ 36"	
PV352	0,5	14" ÷ 36"	

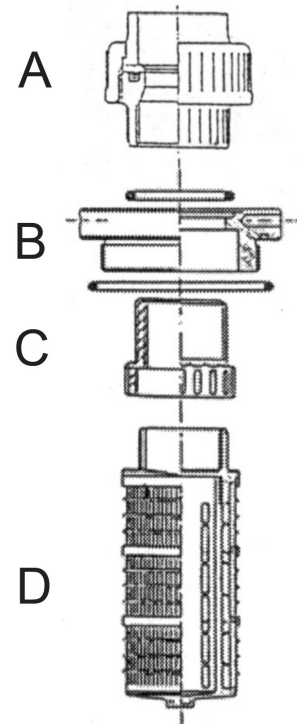

Cylindrical diffusors with elbow

- cylindrical diffuser for vessel 4"-8UN, for upper installation;
- outlet connection with elbow to glue D63;
- 0,2 mm slots or 0,5 mm
- materials: adapter and elbow PVC, diffuser PP;
- flow 20 m³/h at Δp 0,2 bar;
- including:
 - A. elbow D63 (REF. PV331);
 - B. adapter 4" with gasket (REF. PV332);
 - C. reduction 2" M/F (REF. PV335);
 - D. diffuser con diameter 85 mm length 180 mm (REF.PV340 0,2 mm slots – REF. PV342 0,5 mm slots).

REF.	SLOTS (mm)	VESSEL	
PV350	0,2	14" ÷ 36"	
PV349	0,5	14" ÷ 36"	

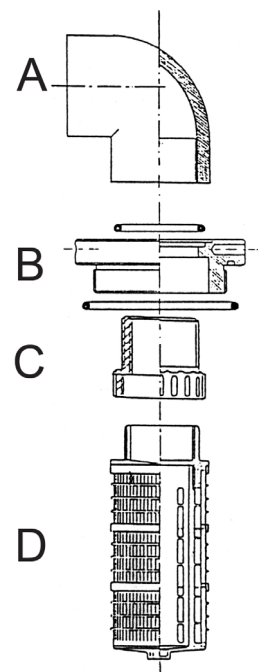



Flanged upper diffusors

- upper diffusor 6" flanged, complete with bolts, nuts, washer and O-ring;
- flange material PVC;
- PP cylindrical diffusor 0,2 mm slots or 0,5 mm slots – see data sheet 02-03-05-EN;
- bolts material AISI 304.

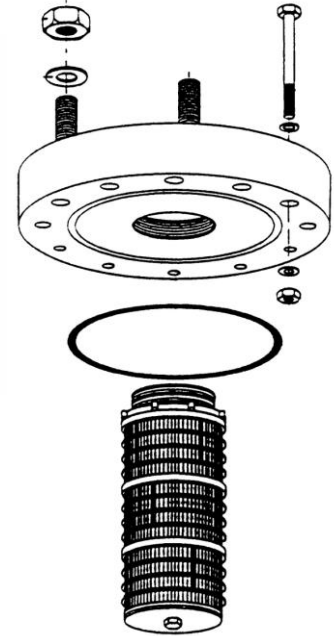

REF.	VESSEL	OUTLET	CYLINDRICAL DIFFUSOR DIAMETER (mm)	CYLINDRICAL DIFFUSOR LENGTH (mm)	SLOTS (mm)	FLOW (m ³ /h) Δp 0,2 bar	
PV512	18" ÷ 36"	DN65	85	284	0,2	20	
PV514	24" ÷ 36"	DN80	120	240	0,2	30	
PV515	42" ÷ 48"	DN80	120	312	0,2	36	
PV553	63"	DN80	120	384	0,2	50	
PV518	63"	DN100	120	384	0,2	60	
PV513	18" ÷ 36"	DN65	85	284	0,5	20	
PV516	24" ÷ 36"	DN80	120	240	0,5	30	
PV517	42" ÷ 48"	DN80	120	312	0,5	36	
PV554	63"	DN80	120	384	0,5	50	
PV519	63"	DN100	120	384	0,5	60	



Cylindrical diffusors

- PP cylindrical diffuser with thread connection 2", 3" or 4";
- slots 0,2 or 0,5 mm.

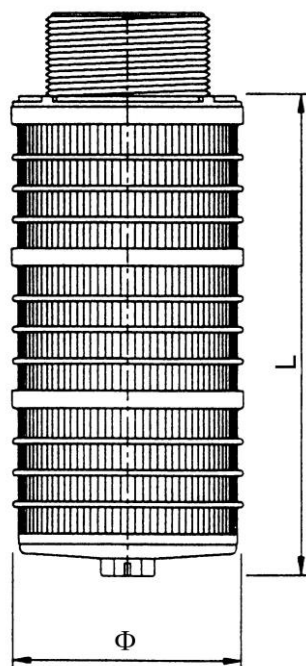

REF.	CONNECTION	DIAMETER (mm)	LENGTH (mm)	SLOTS (mm)	
PV340	2"	85	180	0,2	
PV339	2"	85	284	0,2	
PV341	2"	85	338	0,2	
PV342	2"	85	180	0,5	
PV343	2"	85	284	0,5	
PV344	2"	85	338	0,5	
PV364	3"	120	240	0,2	
PV365	3"	120	312	0,2	
PV366	3"	120	384	0,2	
PV367	3"	120	240	0,5	
PV368	3"	120	312	0,5	
PV369	3"	120	384	0,5	
PV393	4"	120	384	0,2	
PV394	4"	120	384	0,5	



Lower lateral system

- lower lateral system for vessels with 4" – 8UN opening;
- outlet connection to glue D63;
- slots 0,2 or 0,5 mm;
- materials: adapter PVC, hub and laterals PP;
- including:
 - A. union D63 (REF. PV329);
 - B. adapter 4" with O-rings (REF. PV332);
 - C. reduction 2" M/F (REF. PV335);
 - D. n.3 spacers (REF. PV337);
 - E. hub (REF. PV336);
 - F. N.5 laterals diameter 54 mm, length = see table.

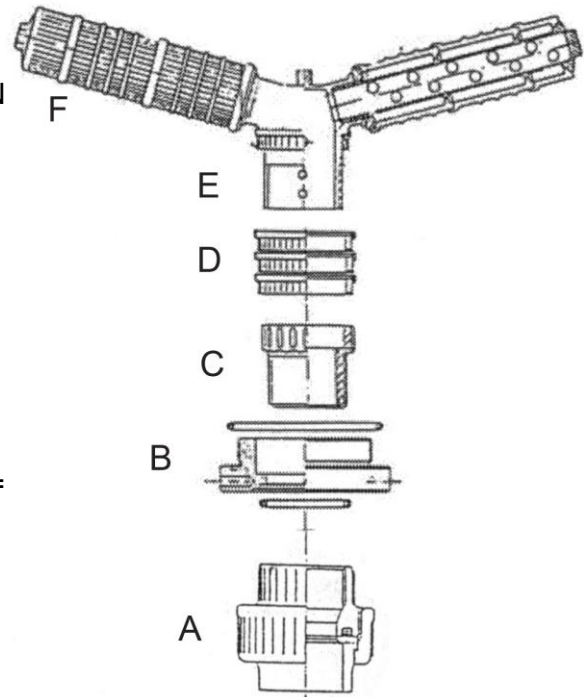

REF.	VESSEL	LATERALS LENGHT (mm)	SLOTS (mm)	FLOW (m ³ /h) Δp 0,2 bar	
PV353	14" - 16" - 18"	113	0,2	16	
PV354	21" - 24"	175	0,2	17	
PV355	30"	237	0,2	18	
PV356	36"	299	0,2	20	
PV360	14" - 16" - 18"	113	0,5	16	
PV361	21" - 24"	175	0,5	17	
PV362	30"	237	0,5	18	
PV363	36"	299	0,5	20	



Lower lateral systems with 6 laterals hub for flanged pressure vessels

- lower lateral system for 6" flanged pressure vessels;
- flange material PVC;
- complete with AISI 304 bolts and washer;
- hub at 6 laterals;
- laterals in PP, slots 0,2 or 0,5 mm, length as table below.

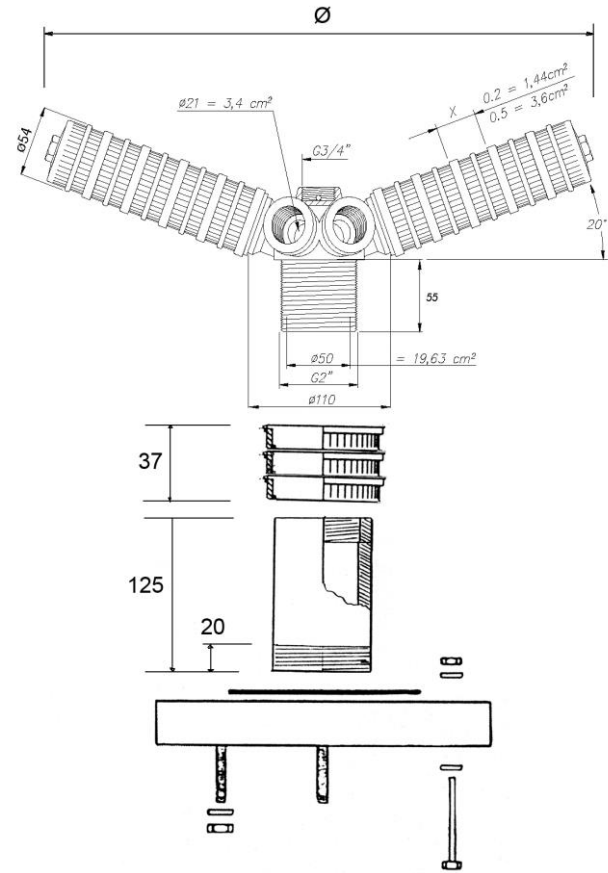

REF.	VESSEL	CONNECTION	LATERALS LENGTH (mm)	DIAMETER Ø (mm)	SLOTS (mm)	FLOW (m³/h) Δp 0,2 bar	
PV520	18" - 21"	DN 65	144	374	0,2	16	
PV521	24"	DN 65	175	432	0,2	17	
PV522	30"	DN 65	237	549	0,2	18	
PV523	36"	DN 65	299	665	0,2	20	
PV524	18" - 21"	DN 65	144	374	0,5	16	
PV525	24"	DN 65	175	432	0,5	17	
PV526	30"	DN 65	237	549	0,5	18	
PV527	36"	DN 65	299	665	0,5	20	



Lower lateral systems with 8 laterals hub for flanged pressure vessels

- lower lateral system for 6" flanged pressure vessels;
- flange material PVC;
- complete with AISI 304 bolts and washer;
- hub at 8 laterals;
- laterals in PP, slots 0,2 or 0,5 mm, length as table below.

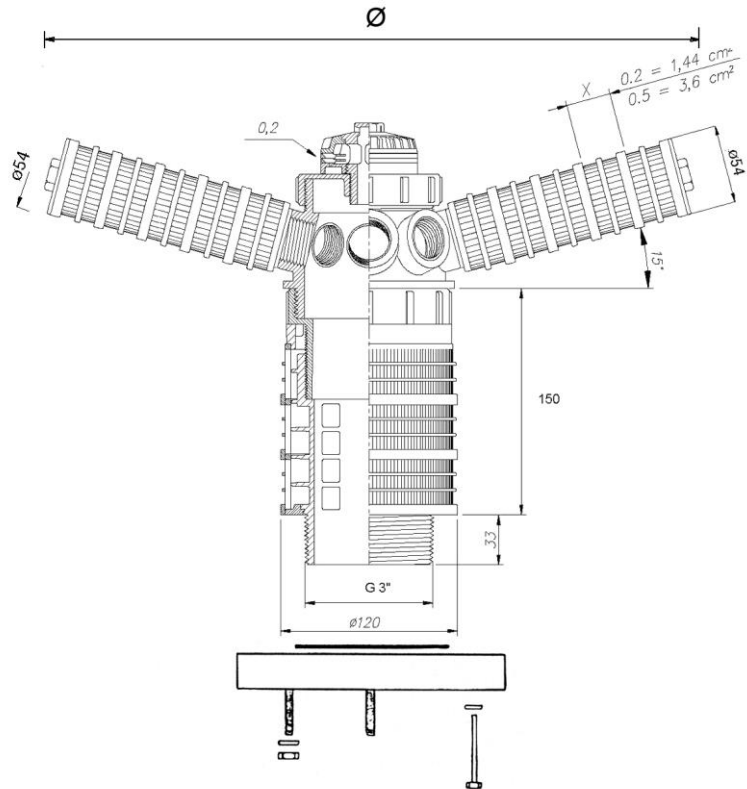

REF.	VESSEL	CONNECTION	LATERALS LENGTH (mm)	DIAMETER Ø (mm)	SLOTS (mm)	FLOW (m ³ /h) Δp 0,2 bar	
PV522A	30"	DN 65	237	580	0,2	28	
PV523A	36"	DN 65	299	699	0,2	30	
PV528	24"	DN 80	175	461	0,2	26	
PV529	30"	DN 80	237	580	0,2	28	
PV530	36"	DN 80	299	699	0,2	30	
PV526A	30"	DN 65	237	580	0,5	28	
PV527A	36"	DN 65	299	699	0,5	30	
PV531	24"	DN 80	175	461	0,5	26	
PV532	30"	DN 80	237	580	0,5	28	
PV533	36"	DN 80	299	699	0,5	30	



Lower double lateral systems for flanged pressure vessels

- lower double lateral system for 6" flanged pressure vessels;
- flange material PVC, bolts in AISI 304;
- complete with bolts and washer;
- double hub at 8 + 8 laterals;
- laterals in PP, slots 0,2 or 0,5 mm, length as table below.

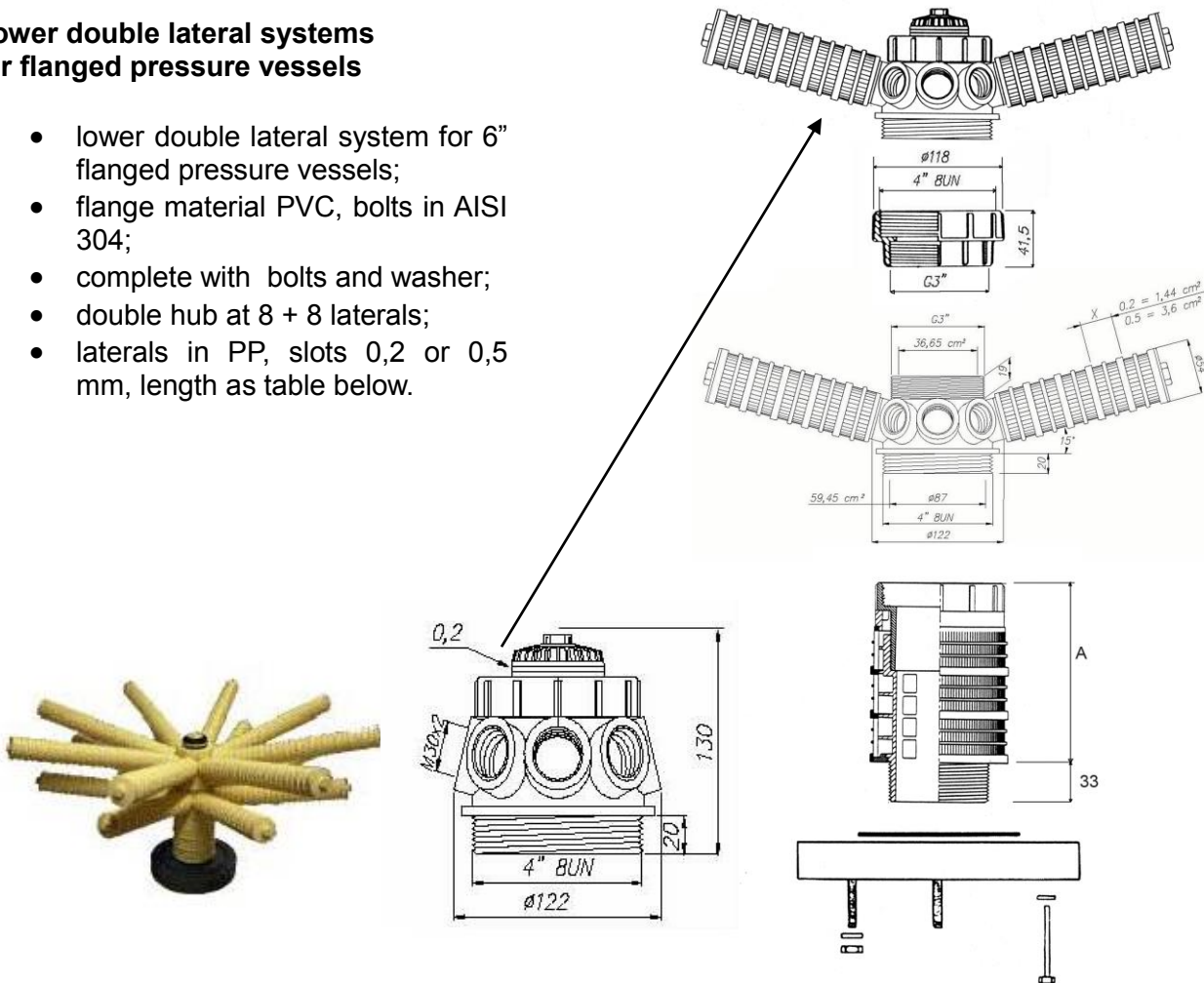

REF.	VESSEL	CONNECTION	LATERALS QUANTITY	A (mm)	LATERALS LENGTH (mm)	SYSTEMS DIAMETERS (mm)	SLOTS (mm)	FLOW (m3/h) Δp 0,2 bar	
PV534	42"	DN 80	8 + 8	150	361 423	819 939	0,2	32	
PV535	48"	DN 80	8 + 8	150	423 485	939 1059	0,2	36	
PV555	63"	DN 80	8 + 8	190	578 640	1239 1359	0,2	50	
PV538	63"	DN 100	8 + 8	190	578 640	1239 1359	0,2	60	
PV536	42"	DN 80	8 + 8	150	361 423	819 939	0,5	32	
PV537	48"	DN 80	8 + 8	150	423 485	939 1059	0,5	36	
PV556	63"	DN 80	8 + 8	190	578 640	1239 1359	0,5	50	
PV539	63"	DN 100	8 + 8	190	578 640	1239 1359	0,5	60	



Top mount lower lateral systems for flanged pressure vessels

- lower lateral system for 6" flanged pressure vessels for top mount valve, with 6 laterals;
- material hub and laterals PP, length as table below;
- slots 0,2 or 0,5 mm;
- to install with 2" adapter for the needed riser tube diameter.

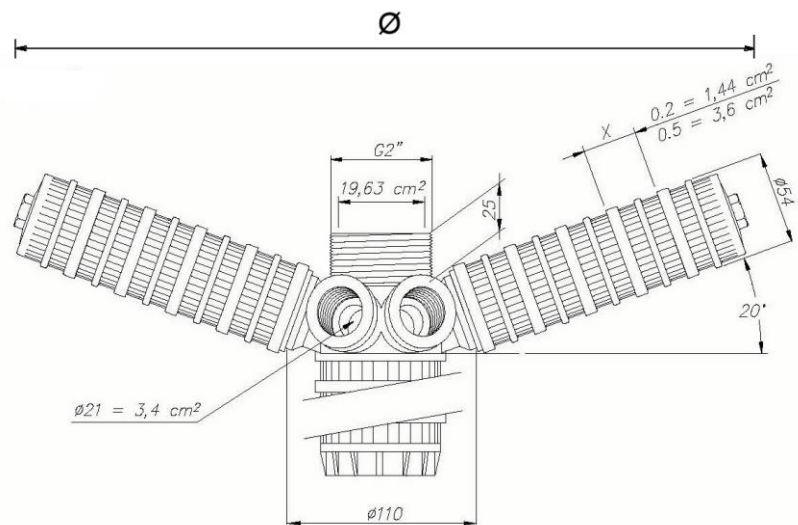

REF.	VESSEL	LATERALS LENGTH (mm)	DIAMETER Ø (mm)	SLOTS (mm)	FLOW (m³/h) Δp 0,2 bar
PV540	18" - 21"	144	374	0,2	16
PV541	24"	175	432	0,2	17
PV542	30"	237	549	0,2	18
PV543	36"	299	665	0,2	20
PV544	18" - 21"	144	374	0,5	16
PV545	24"	175	432	0,5	17
PV546	30"	237	549	0,5	18
PV547	36"	299	665	0,5	20

2" gas adapter

- 2" GAS adapters with connection to glue;
- material PVC.

REF.	CONNECTION TO GLUE (mm)
PV384	41,8
PV385	48,3
PV386	50,0
PV387	63,0

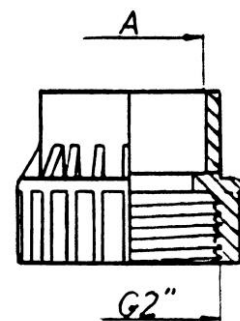

Pressure Vessels Accessories



Top mount lower lateral systems for tubes diameter 90 mm

- lower lateral system for 6" flanged pressure vessels for top mount valve, with 8 laterals;
- material hub and laterals PP, length as table below;
- slots 0,2;
- to glue on tube diameter 90 mm.

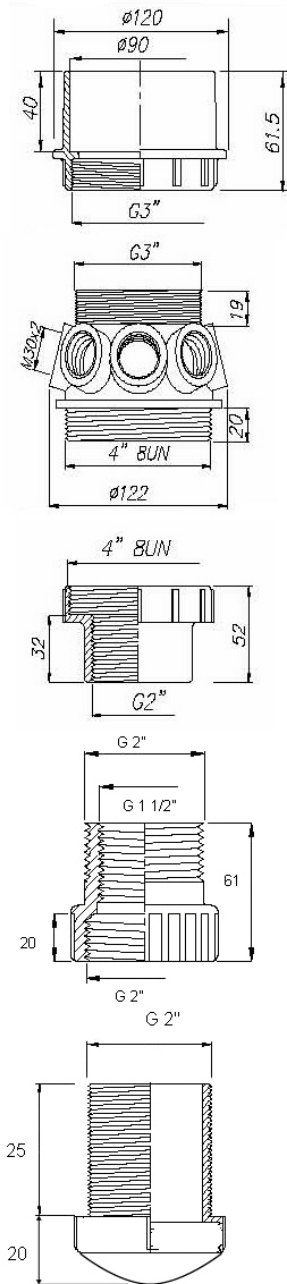
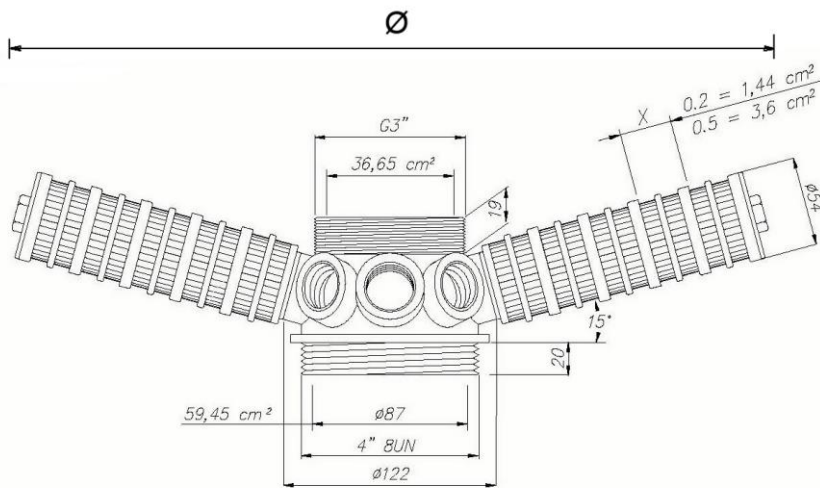

REF.	PRESSURE VESSEL	LATERALS LENGTH (mm)	DIAMETER Ø (mm)	SLOTS (mm)	FLOW (m3/h) Δp 0,2 bar	
PV548	30"	237	580	0,2	28	
PV549	36"	299	699	0,2	30	



Top mount lower double lateral systems for tubes diameter 90 mm

- lower lateral system for 6" flanged pressure vessels for top mount valve, with 8+8 laterals;
- material hub and laterals PP, length as table below;
- slots 0,2;
- to glue on tube diameter 90 mm.

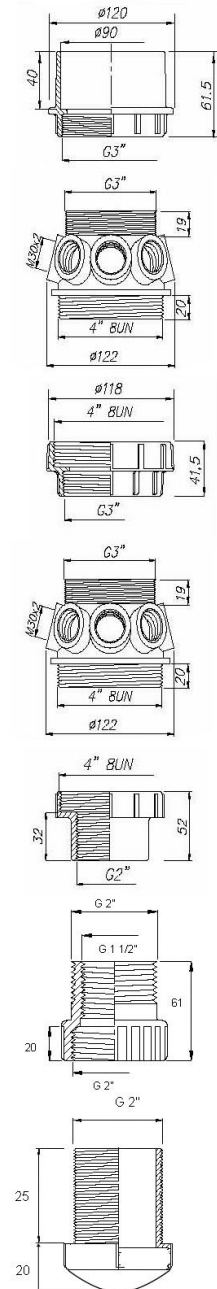
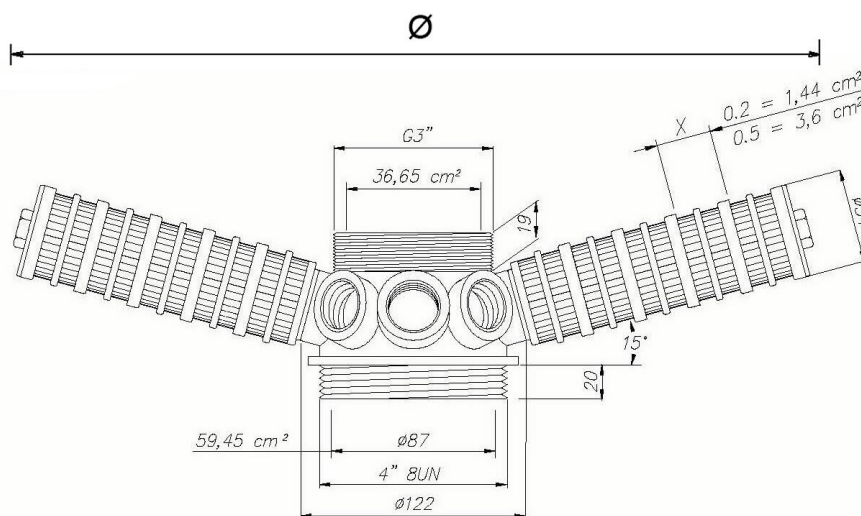

REF.	PRESSURE VESSEL	LATERALS QUANTITY	LATERALS LENGTH (mm)	DIAMETERS Ø (mm)	SLOTS (mm)	FLOW (m3/h) Δp 0,2 bar	
PV550	42"	8 + 8	299 423	699 939	0,2	31	
PV551	48"	8 + 8	361 485	819 1059	0,2	34	



Cylindrical laterals

- cylindrical laterals with threaded connection
- M 30x2;
- material PP;
- diameter 54 mm;
- slots 0,2 or 0,5 mm.

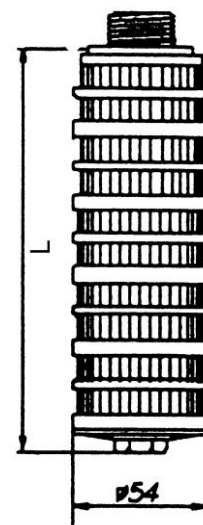

Laterals with 0,2 mm slots											
REF.	PV345	PV370	PV346	PV371	PV347	PV348	PV372	PV373	PV374	PV389	PV391
LENGTH (mm)	113	144	175	206	237	299	361	423	485	578	640

Laterals with 0,5 mm slots											
REF.	PV375	PV376	PV377	PV378	PV379	PV380	PV381	PV382	PV383	PV390	PV392
LENGTH (mm)	113	144	175	206	237	299	361	423	485	578	640

Flange coupling kit

- for 6" flanged pressure vessels;
- including flange adaptor and coupling flange in PVC;
- with gasket in EPDM.

REF.	CONNECTION	
PV594M	DN65	
PV595M	DN80	
PV596M	DN100	





Mineral tank funnels

- The tank funnels are designed for filling mineral tanks with granular media and ion exchange resin;
- the funnels are designed to fit 2,5", 4" and 6" mineral tank openings;
- these economical funnels are nestable to reduce shipping and storage costs;
- the funnel ref. PV395 snaps into a 4" or 6" mineral tank opening for stability when pouring media. The neck of the funnel has been carefully designed to allow trapped air inside the mineral tank to escape when media is poured in. This heavy duty part is blow molded out of high density polyethylene for exceptional strength and durability. The oval design provides an extra wide opening for ease of use when pouring. Handles are molded into the funnel for added convenience.



REF.	DESCRIPTION	
PV295	Funnel 2,5" openings	
PV395	Funnel 4" and 6" openings	

WELLMATE Pressure Vessels



- Pressure Vessels, suitable for industrial and potable water treatment systems;
- Made in U.S.A.;
- In Polyether Urethane (PEU);
- CE and NSF/ANSI 61 certified;
- European 97/23/EC Directive compliant for pressure equipment (PED);
- Max operating external temperature 50°C;
- Max operating internal temperature 38°C;
- Min. operating temperature 4°C;
- Grey colour;
- Warranty 5 years.



REF.	VOLUME (liters)	MAX OPERATING PRESSURE (bar)	DIAMETER (mm)	TOTAL HEIGHT (mm)	IN-OUT HEIGHT FROM THE FLOOR (mm)	CONNECTION (inch)	WEIGHT (kg)
BWM0060	55	8,5	410	660	44	1" NPT M	7
BWM0075	75	8,5	410	810	44	1" NPT M	8
BWM0120	112	8,5	410	1120	44	1" NPT M	11
BWM0150	153	8,5	530	1570	57	1" NPT M	30
BWM0180	178	8,5	610	1050	57	1 ¼" NPT M	23
BWM0235	235	8,5	610	1400	57	1 ¼" NPT M	33
BWM0330	328	8,5	610	1400	57	1 ¼" NPT M	33
BWM0450	453	8,5	610	1890	57	1 ¼" NPT M	43
BWM-LP-075	73	8,5	610	510	57	1" NPT M	11
BWM-LP-130	131	8,5	610	710	57	1" NPT M	14
BWM0600	606	10,0	760	1740	150	2" NPT M	76
BWM-HP-110	114	5,0	410	1110	38	1 ¼" NPT M	12
BWM-HP-150	151	5,0	410	1440	38	1 ¼" NPT M	13
BWM-HP-300	303	5,0	530	1570	51	1 ¼" NPT M	16
BWM-HP-450	454	5,0	610	1840	51	1 ¼" NPT M	29

Note: Diameter, height and weight could change without prior advice.
Not available in stock.



Accessories and Spare Parts:

REF.	DESCRIPTION	
BWM-AC-0600	AIRCELL REPLACEMENT KIT FOR BWM0600	
BWM-AC-0750	AIRCELL REPLACEMENT KIT FOR BWM-IN-0750	
BWM-AC-1000	AIRCELL REPLACEMENT KIT FOR BWM-IN-1000	
BWM-AVC-20290	AIR VOLUME CONTROL ASSEMBLY FOR BWM-HP-110	
BWM-AVC-20288	AIR VOLUME CONTROL ASSEMBLY FOR BWM-HP-150	
BWM-AVC-20287	AIR VOLUME CONTROL ASSEMBLY FOR BWM-HP-300	
BWM-AVC-20291	AIR VOLUME CONTROL ASSEMBLY FOR BWM-HP-450	
BWM-AVC-1	AIR VOLUME CONTROL ASSEMBLY FOR BWM-HP/UT	
BWM-BA-20513	WELLMATE BASE 180/300	
BWM-DA-3174	WM SCREEN & ADAPT. ASSY + O-RING - 4" X 2" NPSM	
BWM-DA-HU79	WM BOTTOM DRAIN + 1 1/4" NPT THREADED PIPES HP110-150	
BWM-DA-HU86	WM BOTTOM DRAIN + 1 1/4" NPT THREADED PIPES HP300-450	
BWM-PB-001	WM PUMP MOUNT BRACKET	
BWM-AI-01	WM AIR INJECTOR/MICRONIZER-HP	
BWM-VB-10724	WM VACUUM BREAKER UT/HP	
BWM-CL-0002	WM "H" CLIP	