



Valves, controllers and accessories



Pressure vessels and accessories



Cabinets



Brine tanks



Membranes reverse osmosis and Ultra Filtration



Vessels, accessories, rotary pumps



UV sterilizers and spare parts



Filter housings, cartridges and polyphosphate feeders



Ion exchange resins and filtering media



Residential R.O. components



EUROTROL is an Italian Family Company, leader in the water treatment components. It operating on the international market, in over 50 countries, as distributor of a wide range of components for water treatment systems, both residential and industrial.

The long experience on this job allows us to know thoroughly the reality and requirements of the market and to meet our Customer's needs with customized solution too.

Our business philosophy is based on service, respect and attention to Customers, swiftness in replying and delivering.

EUROTROL does not manufacture complete water treatment systems, this is our Customer's job: we just sell components and solutions.

Kindness, quality, service: we hope to have the opportunity to show you that these are our peculiarities.





Valves, controllers and accessories



Pressure vessels and accessories



Cabinets



Brine tanks



Membranes reverse osmosis and Ultra Filtration



Vessels, accessories, rotary pumps



UV sterilizers and spare parts



Filter housings, cartridges and polyphosphate feeders



Ion exchange resins and filtering media



Residential R.O. components

INDEX



Valves,
controllers
and accessories



366-604 Autotrol Residential Valves



- for automatic and residential water softening systems;
- valve body in NSF listed Noryl plastic material;
- valve rubber compounded for cold water, NSF listed material;
- operating flow rate $K_v = 2$;
- backwash flow rate = 7 lpm @ Δp 1,72 bar;
- resin volume range = 5 ÷ 25 litres;
- with 606 electronic volumetric controller;
- with European transformer 12/230V – 50Hz;
- accessories (e.g. upper screen, etc.) not included.



Characteristics	
Pressure vessel connection	Threaded 2 ½" - 8 UN male
Brine line connection	Threaded ¾" BSPT male
Distributor tube O. D. diameter	1,05" (= 27 mm)
Distributor tube length above pressure vessel	29 ± 3 mm
Weight (valve + controller)	1,7 kg

366-604 Autotrol Residential Valves



Pressure Drop Diagram

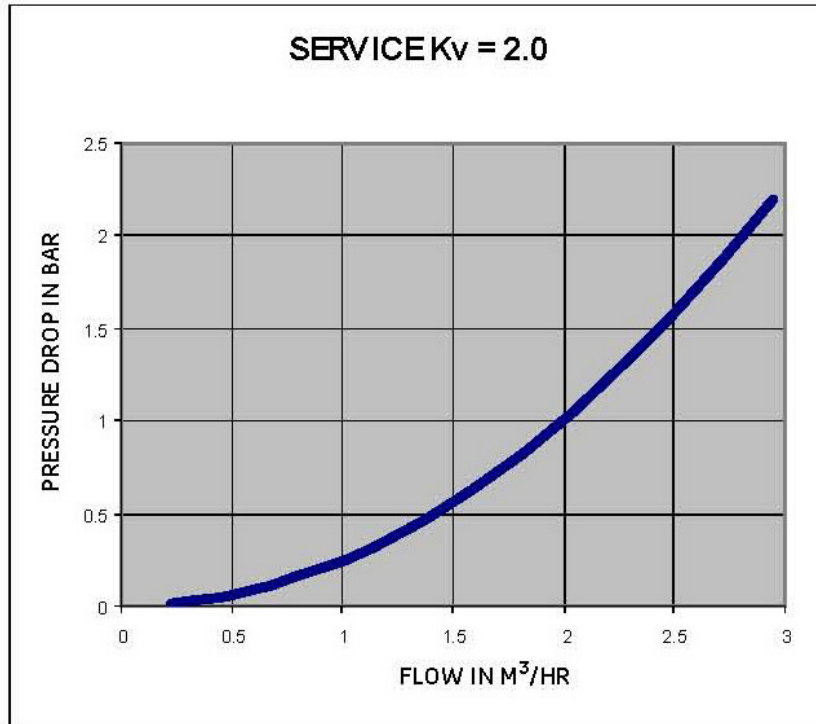

Recommended Operating Conditions	
Operating pressure	1,38 ÷ 8,27 bar
Water temperature	2°C ÷ 38°C

Model	Description	
366/604	Electronic Chronometric	

Autotrol Residential Valves Series 368



- For automatic and residential water softening systems;
- Valve body in NSF listed Noryl plastic material;
- Valve rubber compounded for cold water, NSF listed material;
- Operating flow rate Kv = 3,68;
- Backwash flow rate = 10 lpm @ Δp 1,72 bar;
- Resin volume range = 5 ÷ 25 litres;
- Available with the following controllers:
 - 604 electronic chronometric;
 - 606 electronic volumetric;
- With European transformer 12/230V – 50Hz;
- Accessories (e.g. upper screen, etc.) not included;
- Programmable chronometric regeneration (calendar override) and consumption statistical data memory.



Characteristics	
Pressure vessel connection	Threaded 2 ½" - 8 UN male
Brine line connection	Threaded ¾" BSPT male
Distributor tube O. D. diameter	1,05" (= 27 mm)
Distributor tube length above pressure vessel	29 ± 3 mm
Weight (valve + controller)	1,7 kg



Pressure Drop Diagram

SERVICE Kv = 3,7

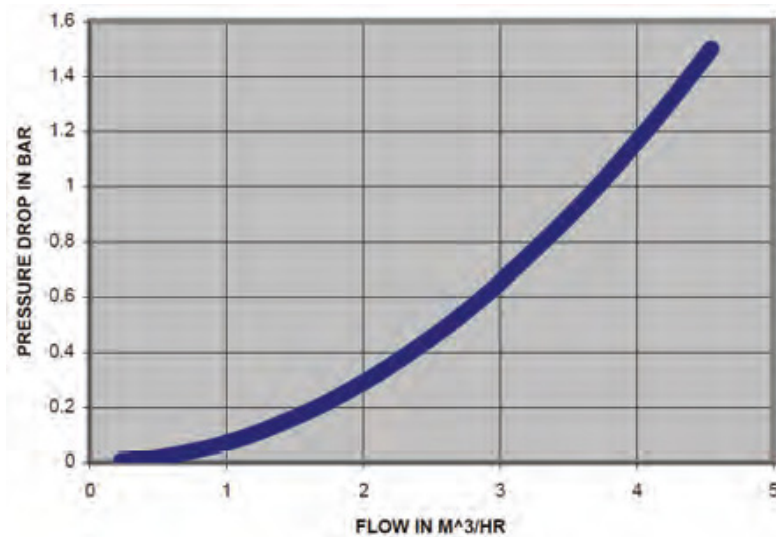

Recommended Operating Condition	
Operating pressure	1,38 ÷ 8,27 bar
Water temperature	2°C ÷ 38°C

Model	Description	
368/604	Electronic Chronometric	
368/606 (*)	Electronic Volumetric	
368/606B	Electronic volumetric with bypass	

(*) NOTE: It's not possible to coupling the bypass with a valve shipped without bypass.

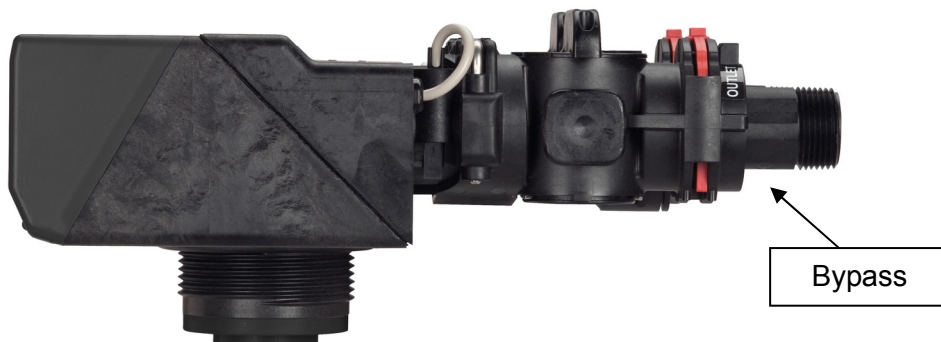

Autotrol Residential Valves Series 255 with Series 400 Controller



- for automatic and residential water softening systems;
- valve body in NSF listed Noryl plastic material;
- valve rubber compounded for cold water, NSF listed material;
- operating flow rate $K_v = 3,4$;
- backwash flow rate = 22,7 lpm @ Δp 1,72 bar;
- resin volume range = 5 ÷ 75 litres;
- available with series 400 controller (see 01-03-01-EN data sheet):
 - 460tc electronic chronometric;
 - 460i electronic volumetric;
- with European transformer 12/230V – 50Hz, except models with 450i pulse controller which need separate alimentation 24V – 50Hz;
- adapters and manifold kit not included, to order separately: see 01-04-01-EN and 01-04-05-EN data sheets;
- accessories (e.g. upper screen, etc.) not included.



Characteristics	
Pressure vessel connection	Threaded 2 ½" - 8 UN male
Brine line connection	Threaded ¼" NPT male
Distributor tube O. D. diameter	1,05" (= 27 mm)
Distributor tube length above pressure vessel	29 ± 3 mm
Weight (valve + controller)	1,8 kg

Autotrol Residential Valves Series 255 with Series 400 Controller



Pressure Drop Diagram

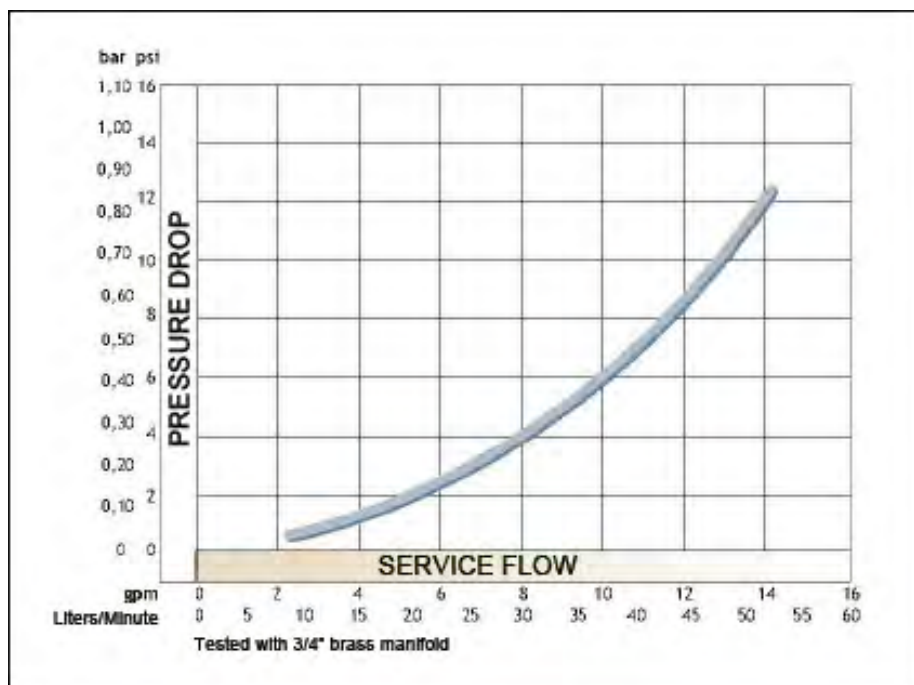

Recommended Operating Conditions

Operating pressure	1,38 ÷ 8,27 bar
Water temperature	2°C ÷ 38°C

Model	Description	Option	
255/460tc	Electronic Chronometric: 118'	59'	
255/460tc	Electronic Chronometric 118' modular camshaft	XS	
255/460i	Electronic Volumetric 118'	59'	
255/460i	Electronic Volumetric modular camshaft	XS-LR-WS	

Autotrol Residential Valves Series 255 with Series Logix Controller



- for automatic and residential water softening systems;
- valve body in NSF listed Noryl plastic material;
- valve rubber compounded for cold water, NSF listed material;
- operating flow rate $K_v = 3,4$;
- backwash flow rate = 22,7 lpm @ Δp 1,72 bar;
- resin volume range = 5 ÷ 75 litres;
- available with series LOGIX controller (see 01-03-02-EN data sheet):
 - 740 C electronic chronometric;
 - 760 C electronic volumetric;
 - 742 C electronic chronometric programmable;
 - 762 C electronic volumetric programmable;
- with European transformer 12/230V – 50Hz;
- adapters and manifold kit not included, to order separately:
see 01-04-01-EN and 01-04-05-EN data sheets;
- accessories (e.g. upper screen, etc.) not included.



Characteristics	
Pressure vessel connection	Threaded 2 ½" - 8 UN male
Brine line connection	Threaded ¼" NPT male
Distributor tube O. D. diameter	1,05" (= 27 mm)
Distributor tube length above pressure vessel	29 ± 3 mm
Weight (valve + controller)	1,8 kg

Autotrol Residential Valves Series 255 with Series Logix Controller



Pressure Drop Diagram

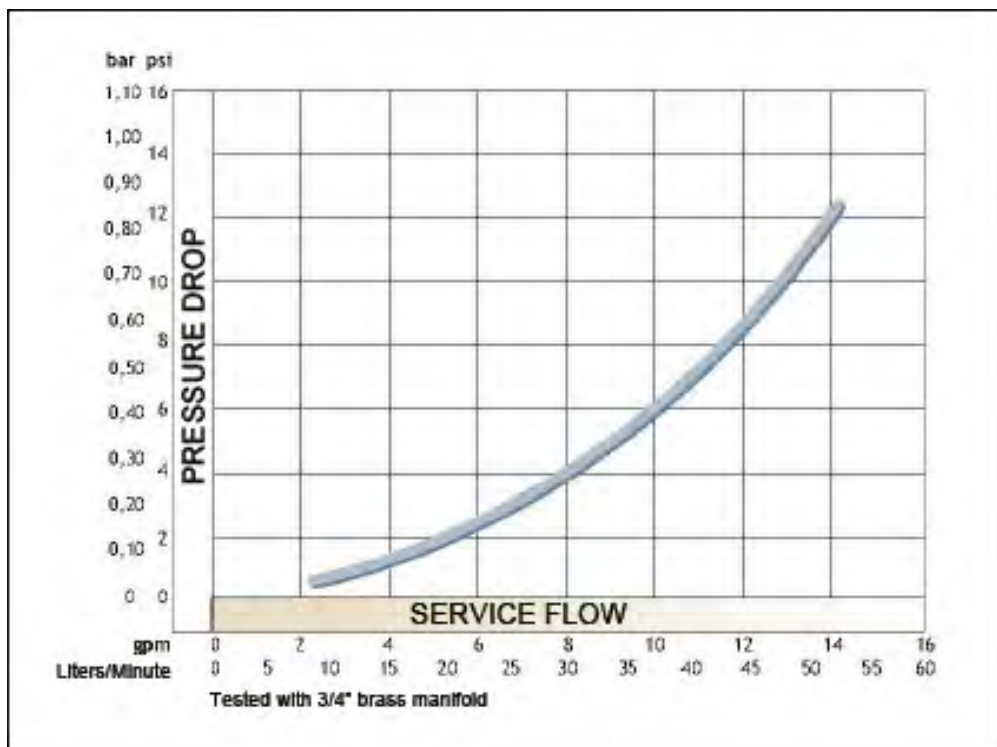

Recommended Operating Conditions

Operating pressure	1,38 ÷ 8,27 bar
Water temperature	2°C ÷ 38°C

Model	Description
255/740 Logix	Electronic Chronometric
255/742 Logix	Electronic Chronometric Programmable
255/760 Logix	Electronic Volumetric
255/762 Logix	Electronic Volumetric Programmable

Residential Duplex Systems with Autotrol Valves Series 255 Twin and 764 Controller



- for automatic and residential / commercial water softening systems;
- for twin alternating and twin parallel systems;
- consisting of n.2 valves (one “main” and another one “secondary”) with 764 electronic volumetric (see 01-03-02-EN data sheet);
- with European transformer 12/230V – 50Hz;
- valve body in NSF listed Noryl plastic material;
- valve rubber compounded for cold water, NSF listed material;
- operating flow rate for each tank $K_v = 3,4$;
- backwash flow rate for each tank = 22,7 lpm @ Δp 1,72 bar;
- resin volume range for each tank = 5 ÷ 75 litres;
- interconnection kit (REF. AV119, see 01-04-01-EN data sheet) and accessories (e.g. upper screen, etc.) not included, to order separately: see 01-04-05-EN data sheet.



Characteristics	
Pressure vessel connection	Threaded 2 ½" - 8 UN male
Drain line connection	Threaded ½" male, included in interconnection kit
Brine line connection	Threaded ¼" NPT male
Distributor tube O. D. diameter	1,05" (= 27 mm)
Distributor tube length above pressure vessel	29 ± 3 mm
Weight (valve + controller)	1,8 kg

Residential Duplex Systems with Autotrol Valves Series 255 Twin and 764 Controller



Pressure Drop Diagram

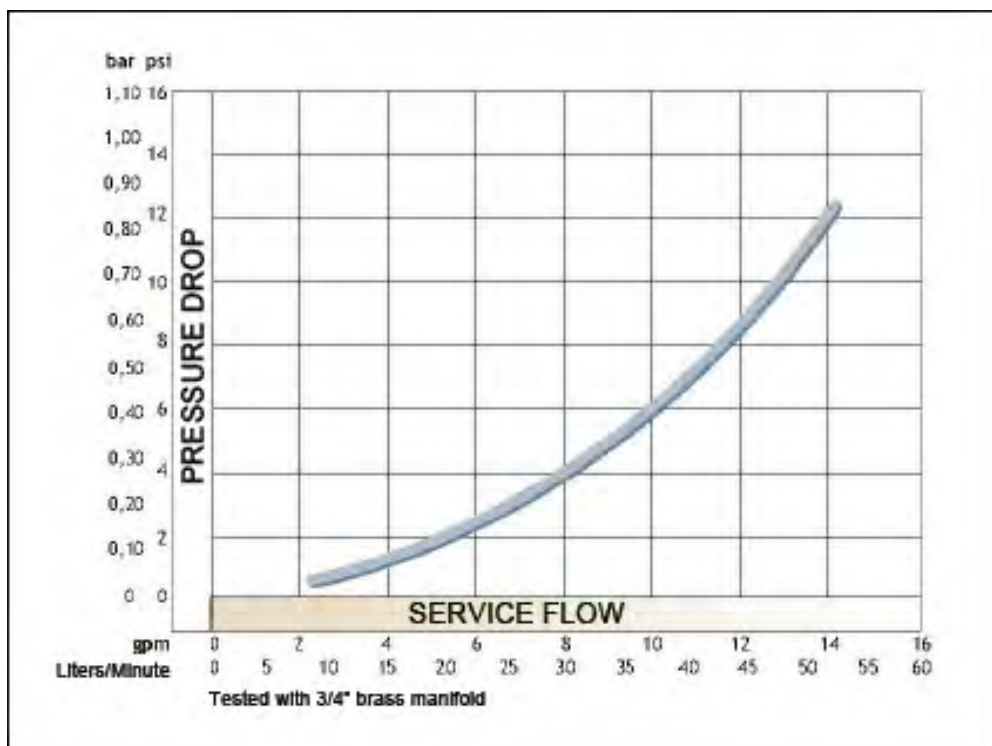

Recommended Operating Conditions

Operating pressure	1,38 ÷ 8,27 bar
Water temperature	2°C ÷ 38°C

Model	Description	
255/764 TWIN	255/764 twin w/o interconnecting piping	

Autotrol Residential Valves Series 255 with 764 Controller for Multitank Systems



- for automatic and residential / commercial water softening systems;
- with electronic volumetric 764 controller (see 01-03-02-EN data sheet);
- for alternating systems;
- valve body in NSF listed Noryl plastic material;
- valve rubber compounded for cold water, NSF listed material;
- operating flow rate for each tank $K_v = 3,4$;
- backwash flow rate for each tank = 22,7 lpm @ Δp 1,72 bar;
- resin volume range for each tank = 5 ÷ 75 litres;
- with European transformer 12/230V – 50Hz for each valve;
- adapters and manifold kit not included, to order separately:
see 01-04-01-EN and 01-04-05-EN data sheets;
- accessories (e.g. upper screen, etc.) not included.



Characteristics

Characteristics	
Pressure vessel connection	Threaded 2 ½" - 8 UN male
Brine line connection	Threaded ¼" NPT male
Distributor tube O. D. diameter	1,05" (= 27 mm)
Distributor tube length above pressure vessel	29 ± 3 mm
Weight (valve + controller)	1,8 kg

Autotrol Residential Valves Series 255 with 764 Controller for Multitank Systems



Pressure Drop Diagram

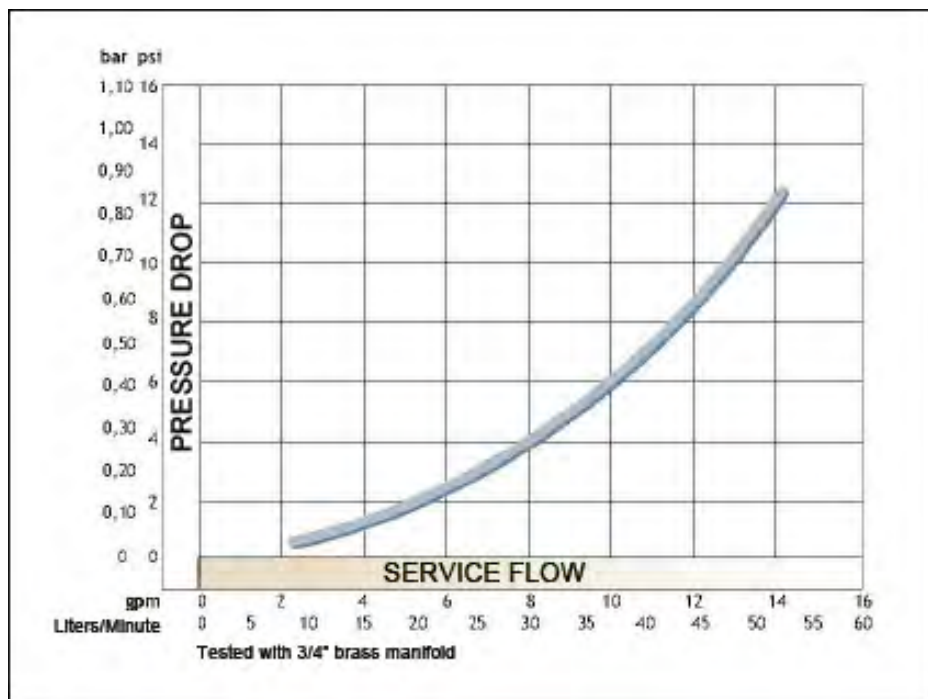

Recommended Operating Conditions	
Operating pressure	1,38 ÷ 8,27 bar
Water temperature	2°C ÷ 38°C

Model	Description	
255/764 SIN	255/764 single multi tank Volumetric	

Autotrol Residential Valves Series 268 with Series 400 Controller



- for automatic and residential water softening systems;
- valve body in NSF listed Noryl plastic material;
- valve rubber compounded for cold water, NSF listed material;
- operating flow rate Kv = 5,6;
- backwash flow rate = 50,4 lpm @ Δp 1,7 bar;
- resin volume range = 30 ÷ 125 litres;
- available with series 400 controller (see 01-03-01-EN data sheet):
 - 460tc electronic chronometric;
 - 460i electronic volumetric;
- with European transformer 12/230V – 50Hz;
- adapters and manifold kit not included, to order separately:
see 01-04-02-EN and 01-04-05-EN data sheets;
- accessories (e.g. upper screen, etc.) not included.



Characteristics	
Pressure vessel connection	Threaded 2 ½" - 8 UN male
Drain line connection	Threaded ¾" NPT, male
Brine line connection	Threaded ¾" NPT, male
Distributor tube O. D. diameter	1,05" (= 27 mm)
Distributor tube length above pressure vessel	29 ± 3 mm
Weight (valve + controller)	2,00 kg

Autotrol Residential Valves Series 268 with Series 400 Controller



Pressure Drop Diagram

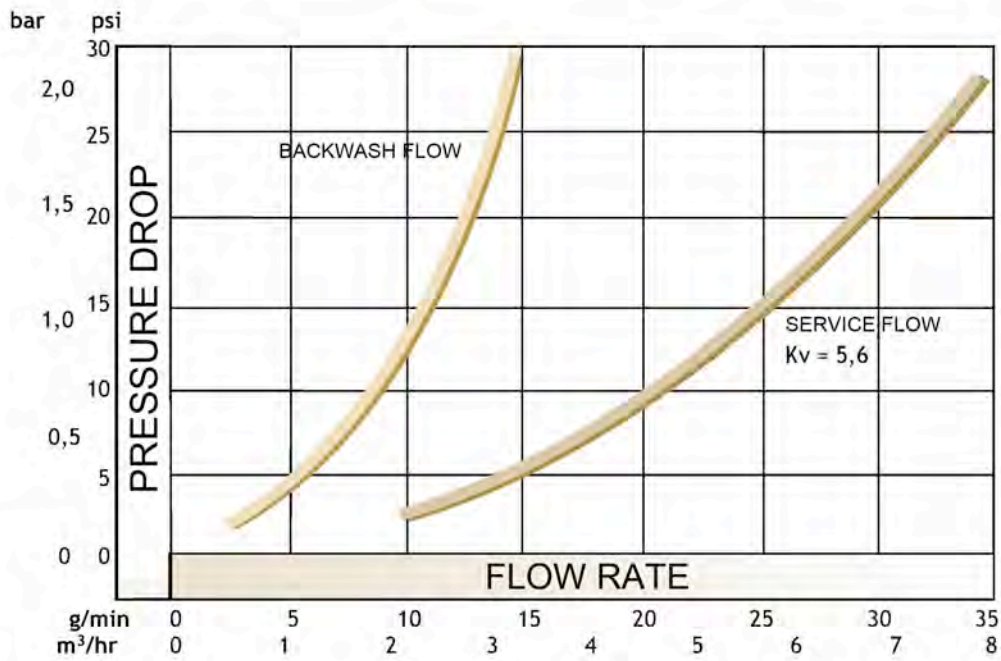

Recommended Operating Conditions

Operating pressure	1,38 ÷ 8,27 bar
Water temperature	2°C ÷ 38°C

Model	Description	Option	
268/460tc	Electronic Chronometric: 118'	XS	
268/460i	Electronic Volumetric: 118'	XS	

Autotrol Residential Valves Series 263 with 460tc Controller



- for automatic and residential water filtration systems;
- with 460tc electronic chronometric controller (see 01-03-01-EN data sheet);
- valve body in NSF listed Noryl plastic material;
- valve rubber compounded for cold water, NSF listed material;
- operating flow rate $K_v = 5,6$;
- backwash flow rate = 75,7 lpm @ Δp 1,72 bar;
- with European transformer 12/230V – 50Hz;
- adapters and manifold kit not included, to order separately:
see 01-04-02-EN and 01-04-05-EN data sheets;
- accessories (ex. upper screen, etc.) not included.



Characteristics	
Pressure vessel connection	Threaded 2 ½" - 8 UN male
Drain line connection	Threaded ¾" NPT, male
Distributor tube O. D. diameter	1,05" (= 27 mm)
Distributor tube length above pressure vessel	29 ± 3 mm
Weight (valve + controller)	2,00 kg
Pressure vessel connection	Threaded 2 ½" - 8 UN male

Autotrol Residential Valves Series 263 with 460tc Controller



Pressure Drop Diagram

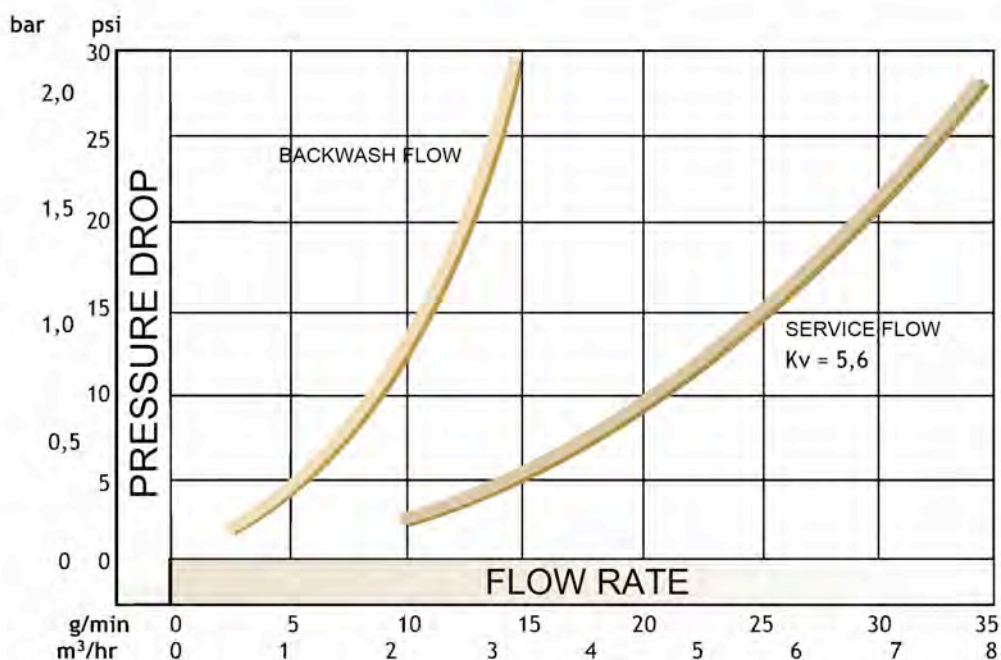

Recommended Operating Conditions

Operating pressure	1,38 ÷ 8,27 bar
Water temperature	2°C ÷ 38°C

Model	Description
263/460tc	Electronic Chronometric: 118' 3 filter cycles

Autotrol Residential Valves Series 268 with Series Logix Controller



- for automatic and residential water softening systems;
- valve body in NSF listed Noryl plastic material;
- valve rubber compounded for cold water, NSF listed material;
- operating flow rate Kv = 5,6;
- backwash flow rate = 75,7 lpm @ Δp 1,72 bar;
- resin volume range = 30 ÷ 125 litres;
- available with series LOGIX controller (see 01-03-02-EN data sheet):
 - 740 C electronic chronometric;
 - 760 C electronic volumetric;
 - 742 C electronic chronometric programmable;
 - 762 C electronic volumetric programmable;
- with European transformer 12/230V – 50Hz;
- adapters and manifold kit not included, to order separately:
see 01-04-02-EN and 01-04-05-EN data sheets;
- accessories (e.g. upper screen, etc.) not included;
- for 268FA/742 and 268FA/762 models see 01-01-10-EN data sheet.



Characteristics	
Pressure vessel connection	Threaded 2 ½" - 8 UN male
Drain line connection	Threaded ¾" NPT, male
Brine line connection	Threaded ¾" NPT, male
Distributor tube O. D. diameter	1,05" (= 27 mm)
Distributor tube length above pressure vessel	½" ± ½" (= 13 ± 13 mm)
Weight (valve + controller)	2,42 kg

Autotrol Residential Valves Series 268 with Series Logix Controller



Pressure Drop Diagram

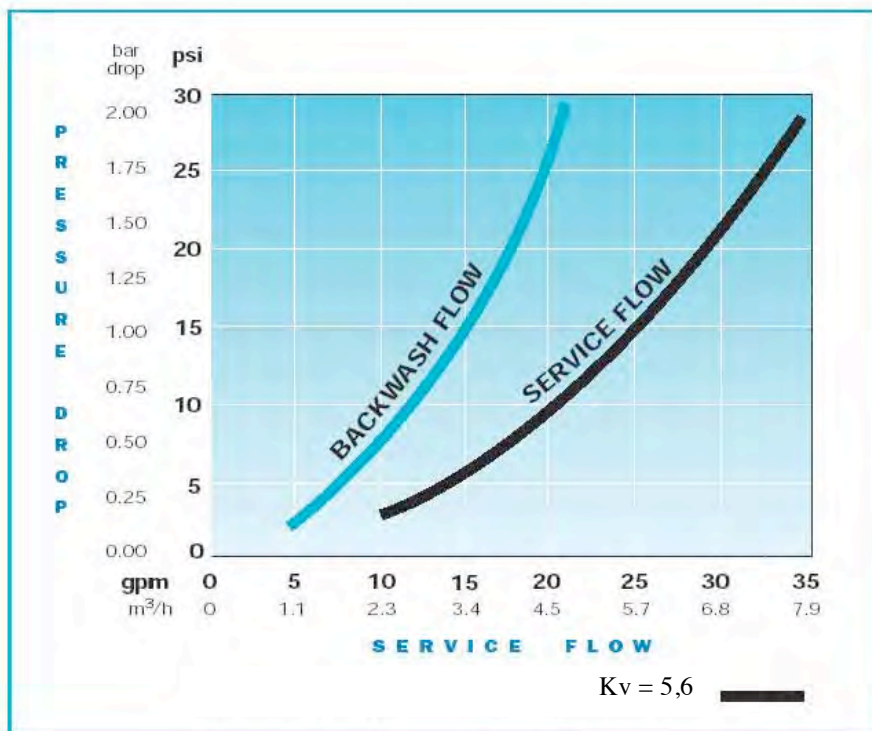

Recommended Operating Conditions	
Operating pressure	1,38 ÷ 8,27 bar
Water temperature	2°C ÷ 38°C

Model	Description	
268/740 Logix	Electronic Chronometric	
268/742 Logix	Electronic Chronometric Programmable	
268/760 Logix	Electronic Volumetric	
268/762 Logix	Electronic Volumetric Programmable	

Autotrol Residential Valves Series 263 with Series Logix Controller



- for automatic and residential water filtration systems;
- valve body in NSF listed Noryl plastic material;
- valve rubber compounded for cold water, NSF listed material;
- operating flow rate Kv = 5,6;
- backwash flow rate = 75,7 lpm @ Δp 1,72 bar;
- available with series LOGIX controller (see 01-03-02-EN data sheet):
 - 740 F electronic chronometric;
 - 760 F electronic volumetric;
 - 742 F electronic chronometric programmable;
 - 762 F electronic volumetric programmable;
- with European transformer 12/230V – 50Hz;
- adapters and manifold kit not included, to order separately:
see 01-04-02-EN and 01-04-05-EN data sheets;
- accessories (e.g. upper screen, etc.) not included.



Characteristics	
Pressure vessel connection	Threaded 2 ½" - 8 UN male
Drain line connection	Threaded ¾" NPT, male
Distributor tube O. D. diameter	1,05" (= 27 mm)
Distributor tube length above pressure vessel	½" ± ½" (= 13 ± 13 mm)
Weight (valve + controller)	2,42 kg
Pressure vessel connection	Threaded 2 ½" - 8 UN male

Autotrol Residential Valves Series 263 with Series Logix Controller



Pressure Drop Diagram

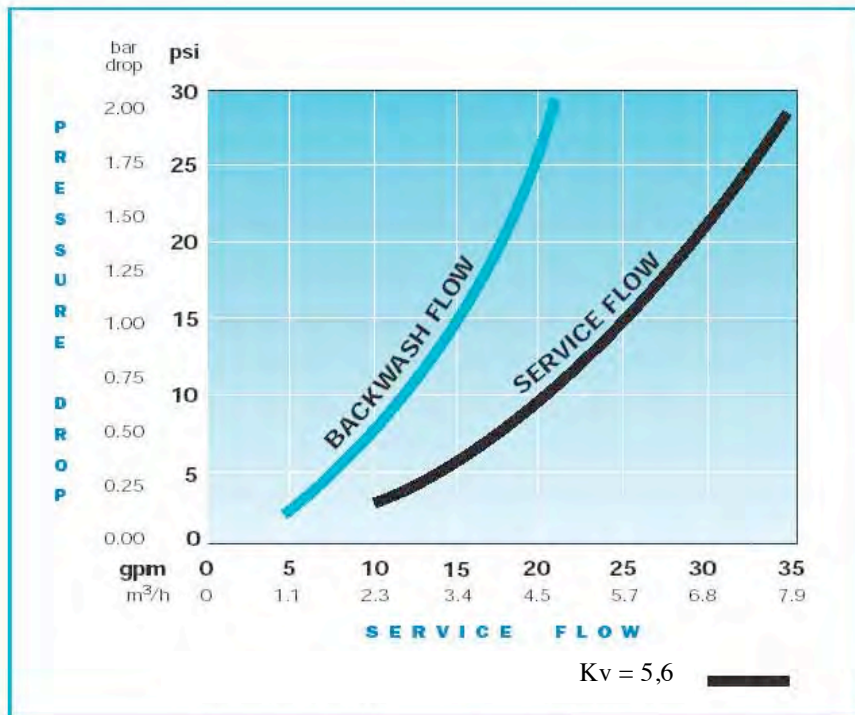

Recommended Operating Conditions

Operating pressure	1,38 ÷ 8,27 bar
Water temperature	2°C ÷ 38°C

Model	Description	
263/740F Logix	Electronic Chronometric – 3 filter cycles	
263/742F Logix	Electronic Chronometric Programmable – 3 filter cycles	
263/760F Logix	Electronic Volumetric – 3 cycles filter	
263/762F Logix	Electronic Volumetric Programmable – 3 filter cycles	

Autotrol Residential Valves Series 268FA with Series Logix Controller



- for automatic and residential water 5 cycles iron removal systems;
- valve body in NSF listed Noryl plastic material;
- valve rubber compounded for cold water, NSF listed material;
- operating flow rate Kv = 5,6;
- backwash flow rate = 75,7 lpm @ Δp 1,72 bar;
- available with series LOGIX controller (see 01-03-02-EN data sheet):
 - 742 F electronic chronometric programmable;
 - 762 F electronic volumetric programmable;
- with European transformer 12/230V – 50Hz;
- adapters and manifold kit not included, to order separately:
see 01-04-02-EN and 01-04-05-EN data sheets;
- accessories (e.g. upper screen, etc.) not included.



Characteristics	
Pressure vessel connection	Threaded 2 ½" - 8 UN male
Drain line connection	Threaded ¾" NPT, male
Distributor tube O. D. diameter	1,05" (= 27 mm)
Distributor tube length above pressure vessel	½" ± ½" (= 13 ± 13 mm)
Weight (valve + controller)	2,42 kg
Pressure vessel connection	Threaded 2 ½"- 8 UN male

Autotrol Residential Valves Series 268FA with Series Logix Controller



Pressure Drop Diagram

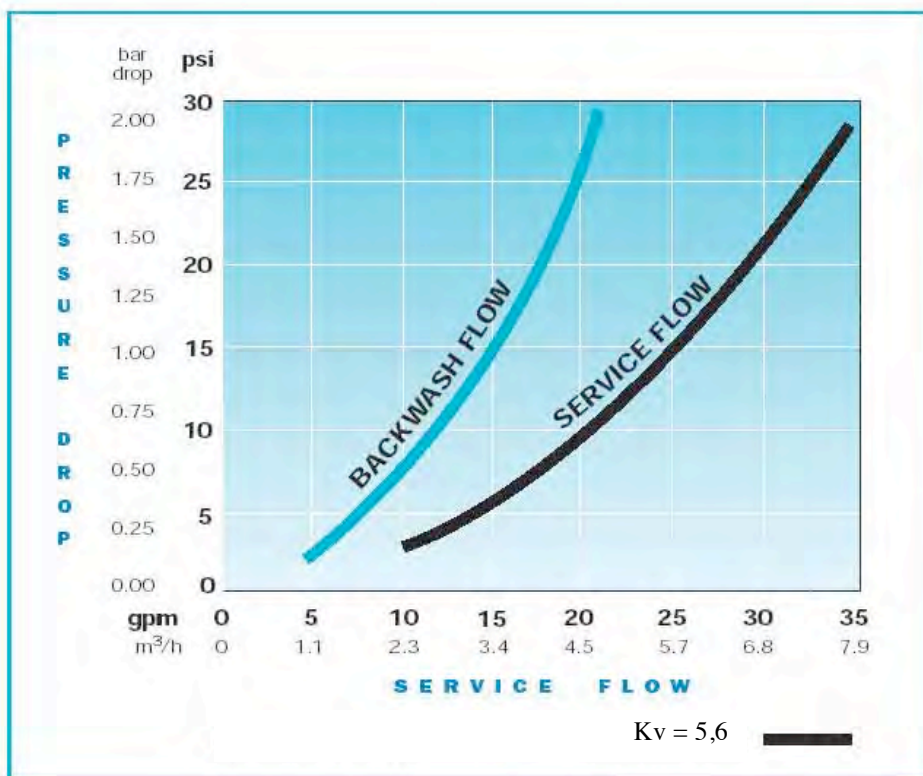

Recommended Operating Conditions

Operating pressure	1,38 ÷ 8,27 bar
Water temperature	2°C ÷ 38°C

Model	Description	
268FA/742 Logix	Electronic Chronometric Programmable – 5 filter cycles	

Autotrol Residential Valves Series 278 with Series Logix Controller



- for automatic water softening systems with high resin volume;
- valve body in NSF listed Noryl plastic material;
- valve rubber compounded for cold water, NSF listed material;
- operating flow rate Kv = 5,6;
- backwash flow rate = 75,7 lpm @ Δp 1,72 bar;
- resin volume range = 45 ÷ 225 litres;
- available with series LOGIX controller (see 01-03-02-EN data sheet):
 - 742 C electronic chronometric programmable;
 - 762 C electronic volumetric programmable;
- with European transformer 12/230V – 50Hz;
- adapters and manifold kit not included, to order separately:
see 01-04-02-EN and 01-04-05-EN data sheets;
- accessories (e.g. upper screen, etc.) not included.



Characteristics	
Pressure vessel connection	Threaded 2 ½" - 8 UN male
Drain line connection	Threaded ¾" NPT, male
Brine line connection	Threaded ⅜" NPT, male
Distributor tube O. D. diameter	1,05" (= 27 mm)
Distributor tube length above pressure vessel	½" ± ½" (= 13 ± 13 mm)
Weight (valve + controller)	2,42 kg

Autotrol Residential Valves Series 278 with Series Logix Controller



Pressure Drop Diagram

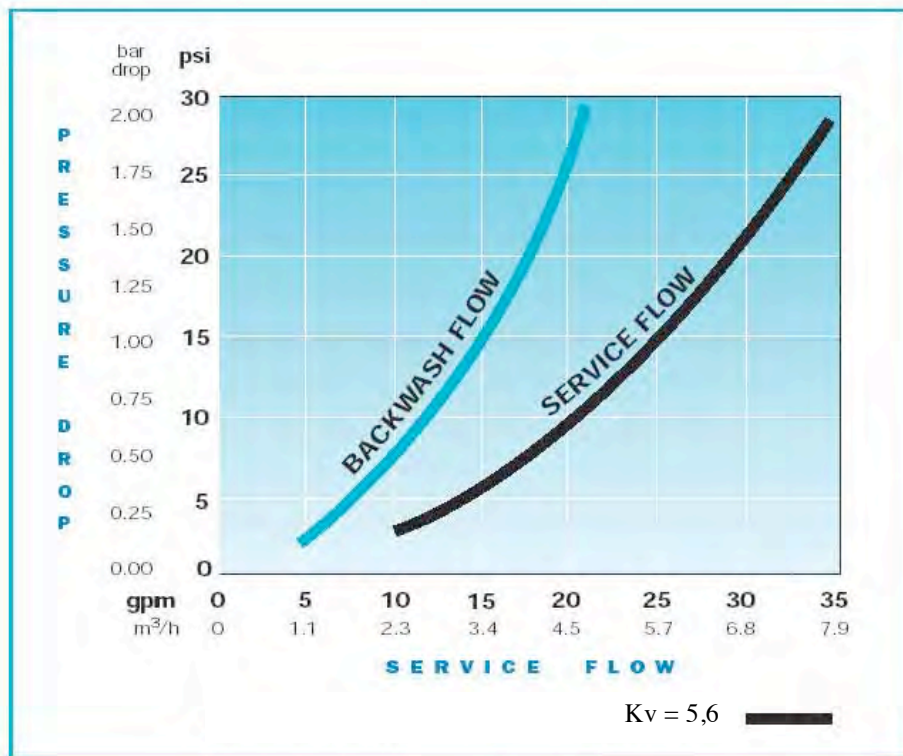

Recommended Operating Conditions	
Operating pressure	1,38 ÷ 8,27 bar
Water temperature	2°C ÷ 38°C

Model	Description	
278/742 Logix	Electronic Chronometric Programmable	
278/762 Logix	Electronic Volumetric Programmable	

Residential Duplex Systems with Autotrol Residential Valves Series 278 Twin and 764 Controller



- for automatic and residential / commercial water softening systems;
- for twin alternating and twin parallel systems;
- consisting of n.2 valves (one “main” and another one “secondary”) with 764 electronic volumetric (see 01-03-02-EN data sheet);
- with European transformer 12/230V – 50Hz;
- valve body in NSF listed Noryl plastic material;
- valve rubber compounded for cold water, NSF listed material;
- operating flow rate for each tank $K_v = 5,6$;
- backwash flow rate for each tank = 75,7 lpm @ Δp 1,72 bar;
- resin volume range for each tank = 45 ÷ 225 litres;
- interconnection kit (see 01-04-03-EN data sheet) and accessories (e.g. upper screen, etc.) not included, to order separately: see 01-04-02-EN and 01-04-05-EN data sheets.



Characteristics	
Pressure vessel connection	Threaded 2 ½" - 8 UN male
Drain line connection	Threaded ¾" NPT, male
Brine line connection	Threaded ¾" NPT, male
Distributor tube O. D. diameter	1,05" (= 27 mm)
Distributor tube length above pressure vessel	½" ± ½" (= 13 ± 13 mm)
Weight (valve + controller)	2,42 kg

Residential Duplex Systems with Autotrol Residential Valves Series 278 Twin and 764 Controller



Pressure Drop Diagram

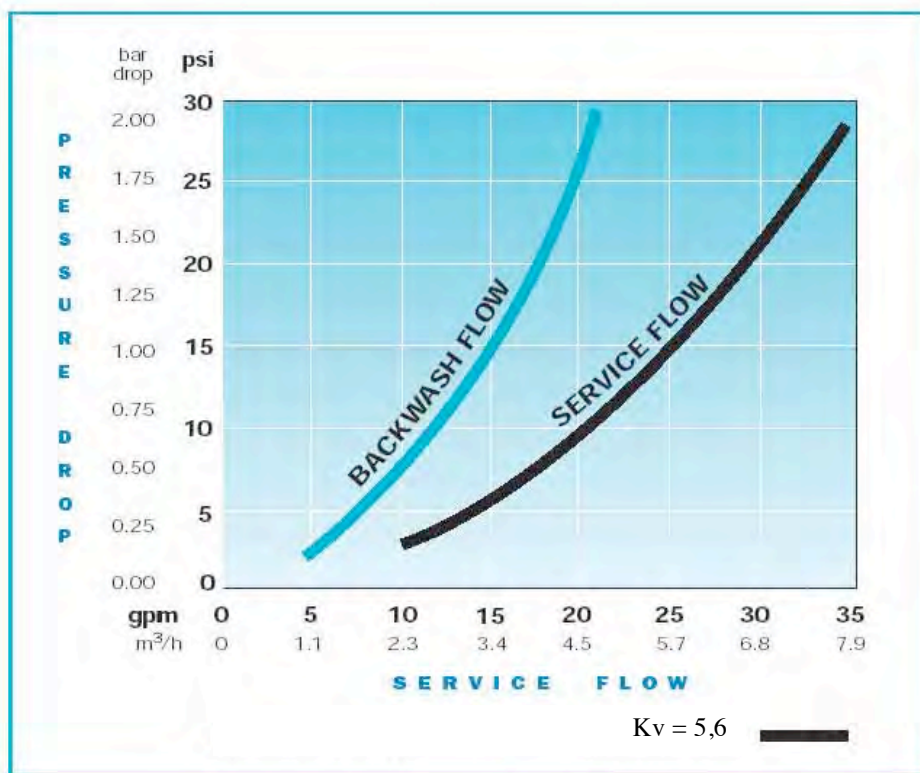

Recommended Operating Conditions	
Operating pressure	1,38 ÷ 8,27 bar
Water temperature	2°C ÷ 38°C

Model	Description	
278/764 TWIN	278/764 twin w/o interconnecting piping	

Autotrol Residential Valves Series 278 with 764 Controller for Multitank Systems



- for automatic and residential / commercial water softening systems;
- with electronic volumetric 764 controller (see 01-03-02-EN data sheet);
- for parallel systems;
- valve body in NSF listed Noryl plastic material;
- valve rubber compounded for cold water, NSF listed material;
- operating flow rate for each tank $K_v = 5,6$;
- backwash flow rate for each tank = 75,7 lpm @ Δp 1,72 bar;
- resin volume range for each tank = 45 ÷ 225 litres;
- with European transformer 12/230V – 50Hz for each valve;
- adapters and manifold kit not included, to order separately:
see 01-04-02-EN and 01-04-05-EN data sheets;
- accessories (e.g. upper screen, etc.) not included.



Characteristics	
Pressure vessel connection	Threaded 2 ½" - 8 UN male
Connesione linea di scarico	Threaded ¾" NPT, male
Brine line connection	Threaded ⅜" NPT, male
Distributor tube O. D. diameter	1,05" (= 27 mm)
Distributor tube length above pressure vessel	½" ± ½" (= 13 ± 13 mm)
Weight (valve + controller)	2,42 kg

Autotrol Residential Valves Series 278 with 764 Controller for Multitank Systems



Pressure Drop Diagram

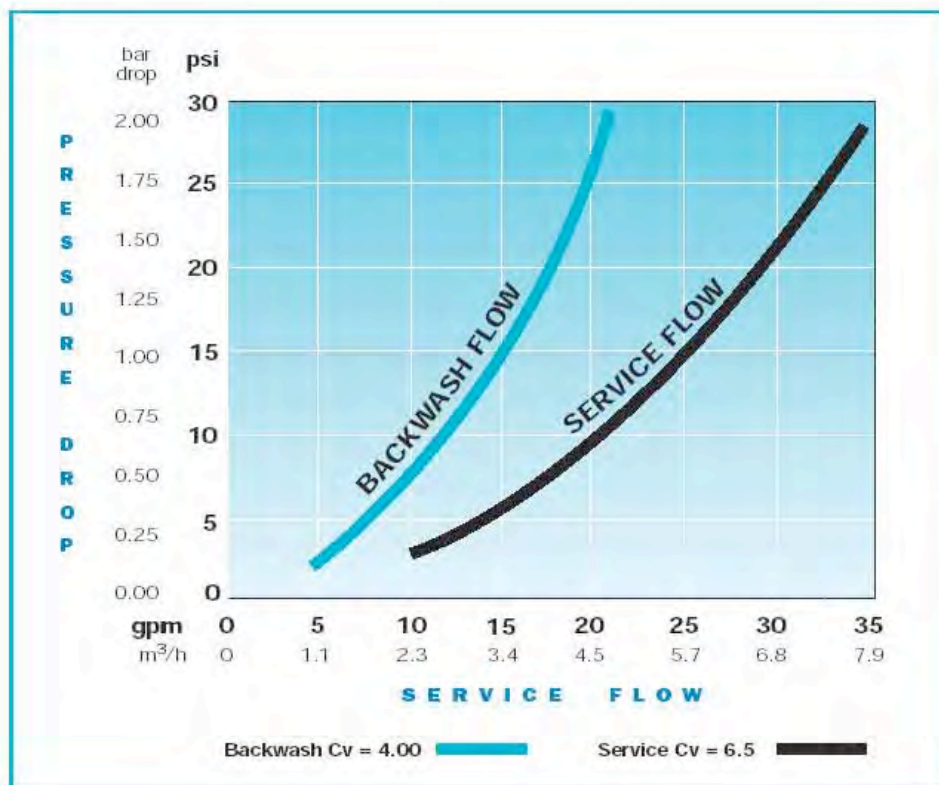

Recommended Operating Conditions	
Operating pressure	1,38 ÷ 8,27 bar
Water temperature	2°C ÷ 38°C

Model	Description	
278/764 SIN	278/764 single multi tank Volumetric	

Autotrol Industrial Softening Magnum CV 1,5" Valves with Series Logix Controller



- for automatic and industrial water softening systems;
- valve body in NSF listed Noryl plastic material with 304 Stainless Steel tank adapter (for heavy applications, like iron removal using $KMnO_4$ or decarbonisation using HCl, the Noryl tank adapter is available on request);
- o-rings in EPDM material;
- operating flow rate $K_v = 17$;
- backwash flow rate = 337 lpm @ Δp 1,72 bar;
- resin volume range = 100 ÷ 700 litres;
- available with series LOGIX controller (see 01-03-02-EN data sheet):
 - 742 electronic chronometric programmable;
 - 762 electronic volumetric programmable;
- with European transformer 12/230V – 50/60 Hz;
- available with or without by-pass;
- adapters, manifold kit and accessories (e.g. upper screen, etc.) not included, to order separately: see 01-04-04-EN and 01-04-05-EN data sheets;
- brine tank refill system doesn't need a brine valve, but just an air-check;
- PVC 2" side mounting adapter available on demand (REF. CC084, see 01-04-04-EN data sheet).



Characteristics	
Pressure vessel connection	Threaded 4" - 8 UN male
Drain line connection	1,5" brass – NPT/BSPT male D50 CPVC to glue
Brine line connection	Threaded ¾" NPT male
Distributor tube O. D. diameter	1,5" (= 48,3 mm)
Pilot drain and auxiliary hydraulic out	¼" tube fitting
Distributor tube length above pressure vessel	16 ± 3 mm
Weight (valve + controller)	12,3 kg

Autotrol Industrial Softening Magnum CV 1,5" Valves with Series Logix Controller



Pressure Drop Diagram

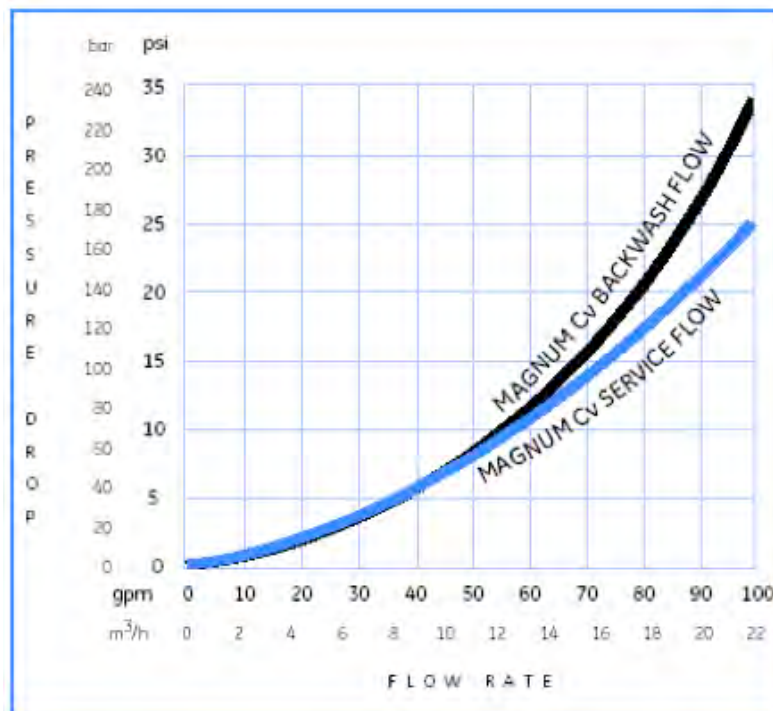

Recommended Operating Conditions

Operating pressure	1,72 ÷ 6,90 bar
Water temperature	1°C ÷ 36°C

Model	Description	Note	
MG Cv 742-HWB	Electronic Chronometric Programmable	With hard water bypass	
MG Cv 742-NHB	Electronic Chronometric Programmable	Without bypass	
MG Cv 762-HWB	Electronic Volumetric Programmable	With hard water bypass	
MG Cv 762-NHB	Electronic Volumetric Programmable	Without bypass	

Autotrol Industrial Magnum CV 1,5" Valves for Filtration with Series Logix Controller



- for automatic and industrial water filtration systems;
- valve body in NSF listed Noryl plastic material with 304 Stainless Steel tank adapter (for heavy applications, like sea water, the Noryl tank adapter is available on request);
- o-rings in EPDM material;
- operating flow rate $K_v = 17$;
- backwash flow rate = 337 lpm @ Δp 1,72 bar;
- available with series LOGIX controller (see 01-03-02-EN data sheet):
 - 742 F electronic chronometric programmable;
 - 762 F electronic volumetric programmable;
- with European transformer 12/230V – 50/60 Hz;
- available with or without by-pass;
- adapters, manifold kit and accessories (e.g. upper screen, etc.) not included, to order separately: see 01-04-04-EN and 01-04-05-EN data sheets;
- PVC 2" side mounting adapter available on demand (REF. CC084, see 01-04-04-EN data sheet).



Characteristics	
Pressure vessel connection	Threaded 4 "- 8 UN male
Drain line connection	1,5" brass – NPT/BSPT male D50 CPVC to glue
Distributor tube O. D. diameter	1,5 " (= 48,3 mm)
Pilot drain and auxiliary hydraulic out	1/4" tube fitting
Distributor tube length above pressure vessel	16 ± 3 mm
Weight (valve + controller)	12,3 kg

Autotrol Industrial Magnum CV 1,5" Valves for Filtration with Series Logix Controller



Pressure Drop Diagram

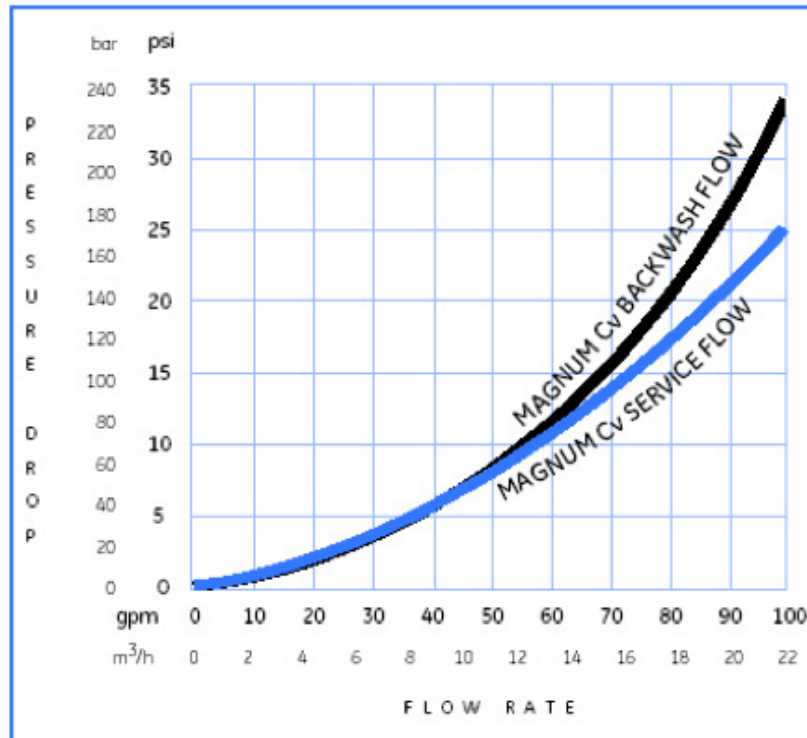

Recommended operating conditions	
Operating pressure	1,72 ÷ 6,90 bar
Water temperature	1 °C ÷ 36 °C

Model	Description	Note	
MG Cv 742F-UWB	Electronic Chronometric Programmable Filtration	With raw water bypass	
MG Cv 742F-NUB	Electronic Chronometric Programmable Filtration	Without bypass	
MG Cv 762F-UWB	Electronic Volumetric Programmable Filtration	With raw water bypass	
MG Cv 762F-NUB	Electronic Volumetric Programmable Filtration	Without bypass	

Autotrol Industrial Softening Magnum IT 2” Valves with Series Logix Controller



- for automatic and industrial water softening systems;
- valve body in NSF listed Noryl plastic material with 304 Stainless Steel tank adapter (for heavy applications, like iron removal using $KMnO_4$ or decarbonisation using HCl, the Noryl tank adapter is available on request);
- o-rings in EPDM material;
- operating flow rate $K_v = 17$;
- backwash flow rate = 337 lpm @ Δp 1,72 bar;
- resin volume range = 100 ÷ 700 litres;
- available with series LOGIX controller (see 01-03-02-EN data sheet):
 - 742 electronic chronometric programmable;
 - 762 electronic volumetric programmable;
- with European transformer 12/230V – 50/60 Hz;
- available with or without by-pass;
- adapters, manifold kit and accessories (e.g. upper screen, etc.) not included, to order separately: see 01-04-04-EN and 01-04-05-EN data sheets;
- brine tank refill system doesn't need a brine valve, but just an air-check;
- PVC 2” side mounting adapter available on demand (REF. CC084, see 01-04-04-EN data sheet).



Characteristics	
Pressure vessel connection	Threaded 4 ”- 8 UN male
Drain line connection	1,5” brass – NPT/BSPT male D50 CPVC to glue
Brine line connection	Threaded ¾” NPT male
Distributor tube O. D. diameter	1,5 ” (= 48,3 mm)
Pilot drain and auxiliary hydraulic out	¼” tube fitting
Distributor tube length above pressure vessel	16 ± 3 mm
Weight (valve + controller)	12,3 kg

Autotrol Industrial Softening Magnum IT 2" Valves with Series Logix Controller



Pressure Drop Diagram

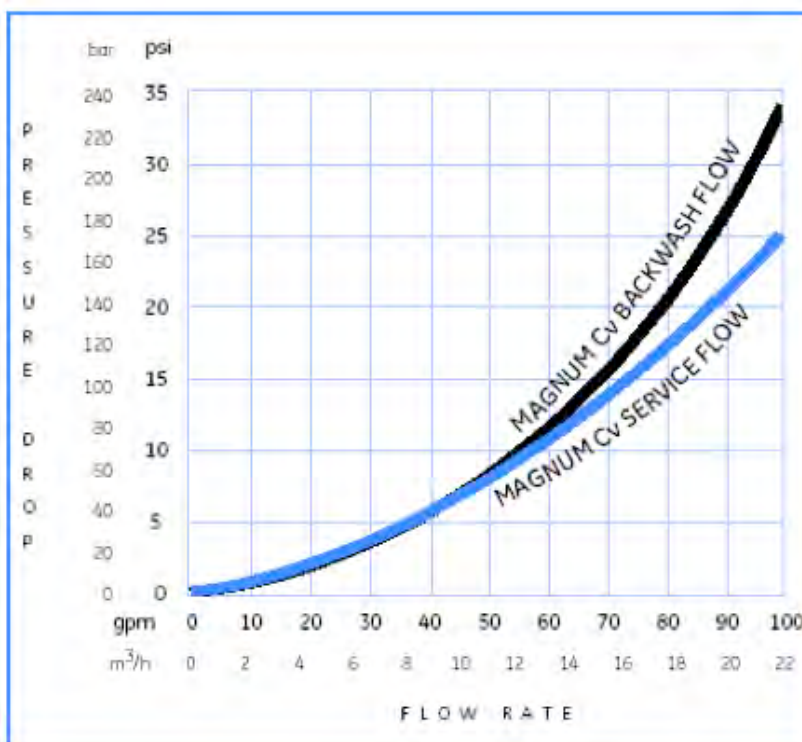

Recommended operating conditions	
Operating pressure	1,72 ÷ 6,90 bar
Water temperature	1°C ÷ 36°C

Model	Description	Note	
MG IT 742- HWB	Electronic Chronometric Programmable	With hard water bypass	
MG IT 742- NHB	Electronic Chronometric Programmable	Without bypass	
MG IT 762- HWB	Electronic Volumetric Programmable	With hard water bypass	
MG IT 762- NHB	Electronic Volumetric Programmable	Without bypass	

Autotrol Industrial Magnum IT 2" Valves for Filtration with Series Logix Controller



- for automatic and industrial water filtration systems;
- valve body in NSF listed Noryl plastic material with 304 Stainless Steel tank adapter (for heavy applications, like sea water, the Noryl tank adapter is available on request);
- o-rings in EPDM material;
- operating flow rate Kv = 17;
- backwash flow rate = 337 lpm @ Δp 1,72 bar;
- available with series LOGIX controller (see 01-03-02-EN data sheet):
 - 742 F electronic chronometric programmable;
 - 762 F electronic volumetric programmable;
- with European transformer 12/230V – 50/60 Hz;
- available with or without by-pass;
- adapters, manifold kit and accessories (e.g. upper screen, etc.) not included, to order separately: see 01-04-04-EN and 01-04-05-EN data sheets;
- PVC 2" side mounting adapter available on demand (REF. CC084, see 01-04-04-EN data sheet).



Characteristics	
Pressure vessel connection	Threaded 4" - 8 UN male
Drain line connection	1,5" brass – NPT/BSPT male D50 CPVC to glue
Distributor tube O. D. diameter	1,5" (= 48,3 mm)
Pilot drain and auxiliary hydraulic out	¼" tube fitting
Distributor tube length above pressure vessel	16 ± 3 mm
Weight (valve + controller)	12,3 kg

Autotrol Industrial Magnum IT 2" Valves for Filtration with Series Logix Controller



Pressure Drop Diagram

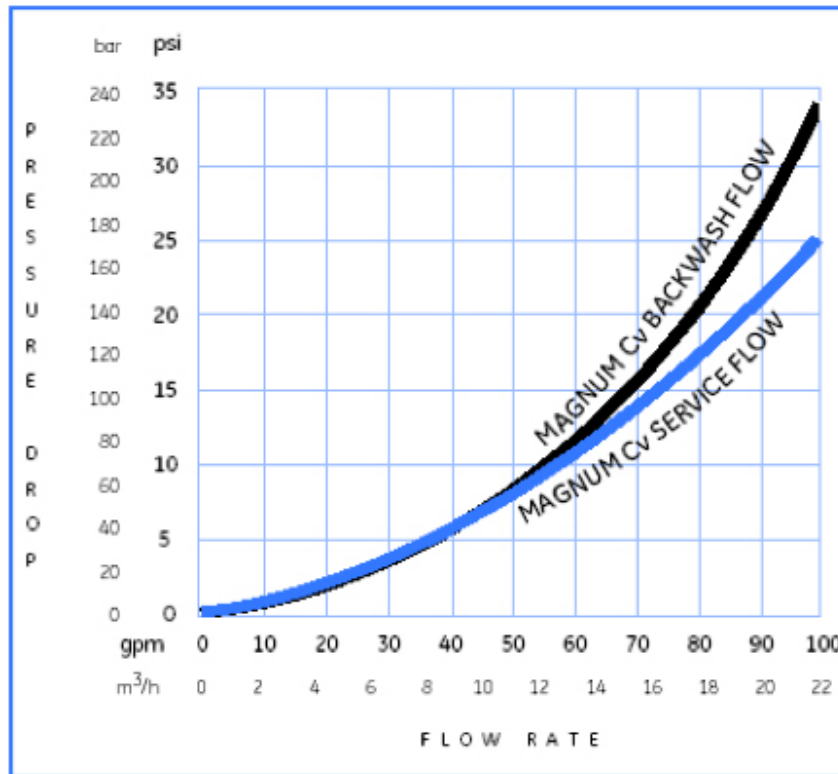

Recommended operating conditions	
Operating pressure	1,72 ÷ 6,90 bar
Water temperature	1°C ÷ 36°C

Model	Description	Note	
MG IT 742- UWB	Electronic Chronometric Programmable Filtration	With raw water bypass	
MG IT 742- NUB	Electronic Chronometric Programmable Filtration	Without bypass	
MG IT 762- UWB	Electronic Volumetric Programmable Filtration	With raw water bypass	
MG IT 762- NUB	Electronic Volumetric Programmable Filtration	Without bypass	

Industrial Duplex Systems with Autotrol Softening Magnum IT 2" Valves and 764 Controller



- for automatic and industrial water softening systems;
- for twin alternating and twin parallel systems;
- consisting of n.2 valves (one "main" and another one "secondary") with 764 electronic volumetric (see 01-03-02-EN data sheet);
- valve body in NSF listed Noryl plastic material with 304 Stainless Steel tank adapter (for heavy applications, like iron removal using $KMnO_4$ or decarbonisation using HCl, the Noryl tank adapter is available on request);
- o-rings in EPDM material;
- operating flow rate for each tank $Kv = 17$;
- backwash flow rate for each tank = 337 lpm @ Δp 1,72 bar;
- resin volume range for each tank = 100 ÷ 700 litres;
- with European transformer 12/230V – 50/60 Hz;
- available with or without by-pass;
- adapters, manifold kit and accessories (e.g. upper screen, etc.) not included, to order separately: see 01-04-04-EN and 01-04-05-EN data sheets;
- brine tank refill system doesn't need a brine valve, but just an air-check;
- PVC 2" side mounting adapter available on demand (REF. CC084, see 01-04-04-EN data sheet);
- interconnection not included.



Characteristics	
Pressure vessel connection	Threaded 4" - 8 UN male
Drain line connection	1,5" brass – NPT/BSPT male D50 CPVC to glue
Brine line connection	Threaded ¾" NPT male
Distributor tube O. D. diameter	1,5" (= 48,3 mm)
Pilot drain and auxiliary hydraulic out	¼" tube fitting
Distributor tube length above pressure vessel	16 ± 3 mm
Weight (valve + controller)	12,3 kg

Industrial Duplex Systems with Autotrol Softening Magnum IT 2" Valves and 764 Controller



Pressure Drop Diagram

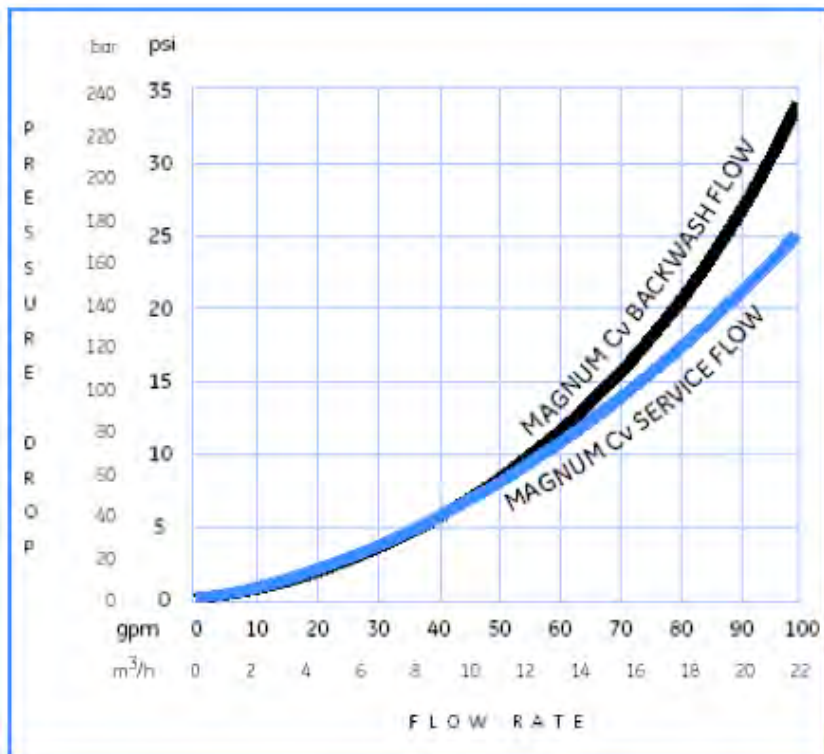

Recommended operating conditions	
Operating pressure	1,72 ÷ 6,90 bar
Water temperature	1°C ÷ 36°C

Model	Description	Note	
MG IT 764 TWIN	Twin alternating/parallel – Softening/Filtration	Without bypass	

Autotrol Industrial Softening Magnum IT 2" Valves with 764 Controller for Multitank Systems



- for automatic and industrial water softening systems;
- with electronic volumetric 764 controller (see 01-03-02-EN data sheet);
- for parallel systems;
- valve body in NSF listed Noryl plastic material with 304 Stainless Steel tank adapter (for heavy applications, like iron removal using $KMnO_4$ or decarbonisation using HCl, the Noryl tank adapter is available on request);
- o-rings in EPDM material;
- operating flow rate for each tank $K_v = 17$;
- backwash flow rate for each tank = 337 lpm @ Δp 1,72 bar;
- resin volume range for each tank = 100 ÷ 700 litres;
- with European transformer 12/230V – 50/60 Hz for each valve;
- available with or without by-pass;
- adapters, manifold kit and accessories (e.g. upper screen, etc.) not included, to order separately: see 01-04-04-EN and 01-04-05-EN data sheets;
- brine tank refill system doesn't need a brine valve, but just an air-check;
- PVC 2" side mounting adapter available on demand (REF. CC084, see 01-04-04-EN data sheet);
- interconnection not included.



Characteristics	
Pressure vessel connection	Threaded 4" - 8 UN male
Drain line connection	1,5" brass – NPT/BSPT male D50 CPVC to glue
Brine line connection	Threaded 3/4" NPT male
Distributor tube O. D. diameter	1,5" (= 48,3 mm)
Pilot drain and auxiliary hydraulic out	1/4" tube fitting
Distributor tube length above pressure vessel	16 ± 3 mm
Weight (valve + controller)	12,3 kg

Autotrol Industrial Softening Magnum IT 2" Valves with 764 Controller for Multitank Systems



Pressure Drop Diagram

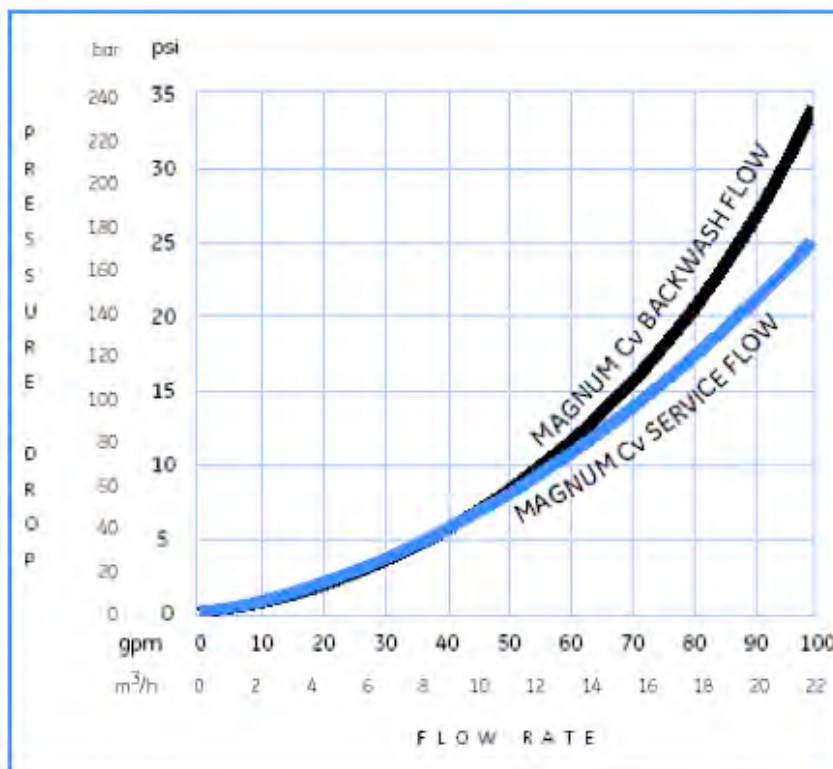

Recommended operating conditions	
Operating pressure	1,72 ÷ 6,90 bar
Water temperature	1°C ÷ 36°C

Model	Description	Note	
MG IT 764-NHB	Electronic Volumetric Multitank	Without bypass	

Autotrol Industrial Magnum IT 2" Valves for Filtration with 764 Controller with Multitank Systems



- for automatic and industrial water filtration systems;
- with electronic volumetric 764 F controller (see 01-03-02-EN data sheet);
- for parallel systems up to 6 tanks;
- valve body in NSF listed Noryl plastic material with 304 Stainless Steel tank adapter (for heavy applications, like sea water, the Noryl tank adapter is available on request);
- o-rings in EPDM material;
- operating flow rate for each tank $K_v = 17$;
- backwash flow rate for each tank = 337 lpm @ Δp 1,72 bar;
- with European transformer 12/230V – 50/60 Hz for each valve;
- available with or without by-pass;
- adapters, manifold kit and accessories (e.g. upper screen, etc.) not included, to order separately: see 01-04-04-EN and 01-04-05-EN data sheets;
- PVC 2" side mounting adapter available on demand (REF. CC084, see 01-04-04-EN data sheet);
- interconnection not included.



Characteristics	
Pressure vessel connection	Threaded 4" - 8 UN male
Drain line connection	1,5" brass – NPT/BSPT male D50 CPVC to glue
Distributor tube O. D. diameter	1,5" (= 48,3 mm)
Pilot drain and auxiliary hydraulic out	¼" tube fitting
Distributor tube length above pressure vessel	16 ± 3 mm
Weight (valve + controller)	12,3 kg

Autotrol Industrial Magnum IT 2" Valves for Filtration with 764 Controller with Multitank Systems



Pressure Drop Diagram

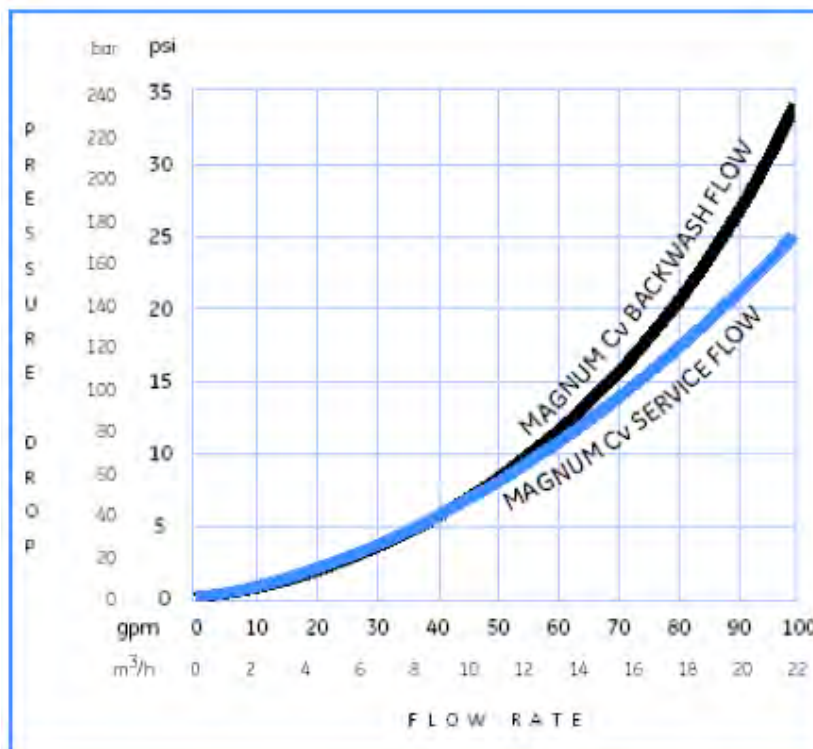

Recommended operating conditions

Operating pressure	1,72 ÷ 6,90 bar
Water temperature	1°C ÷ 36°C

Model	Description	Note	
MG IT 764F-NUB	Electronic Volumetric Multitank Filtration	Without bypass	

Series 400 Controllers for Autotrol Valves Series 255 - 263 – 268



440i



460tc / 460i



Controllers for softeners characteristics			
Characteristic	440i	460tc	460i
Controller type	Electromechanical	Electronic	Electronic
Regeneration mode	Chronometric: 7 or 6 days	Chronometric	Volumetric
Regeneration frequency	Daily	Daily	Daily
Regeneration cycle length	59' or 118'	59' or 118'	59' or 118'
Cycle length	Fixed not modifiable	Fixed not modifiable	Fixed not modifiable
Salt setting	Pounds of salt	Pounds of salt	Pounds of salt

Controllers for filtration characteristics		
Characteristic	440i	460tc
Controller type	Electromechanical	Electronic
Backwash mode	Chronometric: 7 or 6 days	Chronometric
Backwash frequency	Daily	Daily
Filter cycle length	Fixed not modifiable	Fixed not modifiable

Logix Controllers for Autotrol Valves

Series 255 – 263 – 268 – 273 – 278 – 293 – 298



Controllers for softeners characteristics

CHARACT.	740 C	760 C	742 C	762 C	764
Controller type	Electronic	Electronic	Electronic	Electronic	Electronic
Regeneration mode	Chronometric	Volumetric	Chronometric	Volumetric	Volumetric
Regeneration frequency	Fixed day or 0,5 ÷ 99 days calendar override	0,5 ÷ 99 days calendar override	Fixed day or 0,5 ÷ 99 days calendar override	0,5 ÷ 99 days calendar override	0,5 ÷ 99 days calendar override
Adjustable regeneration time	Yes	Yes	Yes	Yes	Yes
Cycle length	Computer calculated	Computer calculated	Fully programmable	Fully programmable	Fully programmable
Salt setting	3 options	3 options	Fully adjustable	Fully adjustable	Fully adjustable

Controllers for filtration characteristics

CHARACT.	740 F	760 F	742 F	762 F	764 F
Controller type	Electronic	Electronic	Electronic	Electronic	Electronic
Backwash mode	Chronometric	Volumetric	Chronometric	Volumetric	Volumetric
Backwash frequency	Fixed day or 0,5 ÷ 99 days calendar override	0,5 ÷ 99 days calendar override	Fixed day or 0,5 ÷ 99 days calendar override	0,5 ÷ 99 days calendar override	0,5 ÷ 99 days calendar override
Adjustable cycle time	Programmable backwash time	Programmable backwash time	Fully programmable	Fully programmable	Fully programmable
Filter cycle length	Computer calculated	Computer calculated	Fully adjustable	Fully adjustable	Fully adjustable



256 bypass kits

- with gaskets, brass adapters, screws and nuts.

REF.	IN/OUT CONNECTION	DRAIN LINE	
AV028	3/4"	1/2"	
AV029	1"	1/2"	

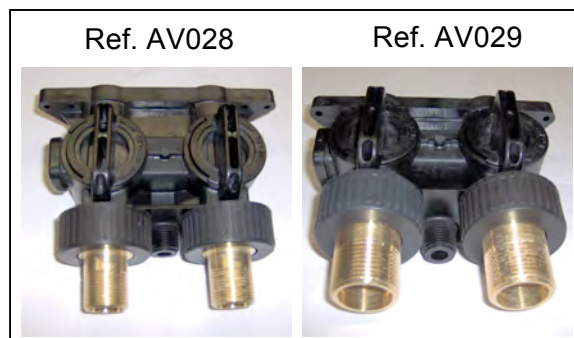

Female manifold kits

- with o-rings, screws and nuts.

REF.	IN/OUT CONNECTION	DRAIN LINE	MATERIAL	
AV013	3/4"	1/2"	NORYL	
AV010	3/4"	3/8"	BRASS	
AV011	1"	1/2"	BRASS	



Female mixing manifold kits

- with o-rings, screws and nuts.

REF.	IN/OUT CONNECTION	DRAIN LINE	MATERIAL	
AV007	3/4"	3/8"	BRASS	
AV012	1"	1/2"	BRASS	



Autotrol Valves Series 255 Accessories



Male manifold kits

- in plastic material Noryl;
- with o-rings, screws and nuts.

REF.	CONNECTIONS IN/OUT	DRAIN LINE	OPTION	
AV001	3/4"	3/4"	WITH TURBINE	
AV001A	3/4"	3/4"	WITHOUT TURBINE	
AV022	1"	1/2"	WITH TURBINE	
AV022A	1"	1/2"	WITHOUT TURBINE	

Ref. AV022



Slim cover for valve 255 Logix

- in plastic material.

REF.	
AW145	

Ref. AW145



D. 32 interconnection kit for 255/764twin residential duplex systems

- special manifold for AUTOTROL 255 valves included;
- for twin alternating and twin parallel systems;
- consisting of:

QUANTITY	DESCRIPTION
2	Adapter PVC-U D = 32 mm - 1"
2	Tee connection PVC-U D = 32 mm
4	Elbow PVC-U D = 32 mm D1 = 25 mm
4	Tube PVC-U D = 32 mm
2	Elbow D = 32 mm
2	Coupling sleeve D = 32 mm
2	Manifold kit with adapter D. 32 to glue
2	256 by-pass with o-rings, screws and nuts

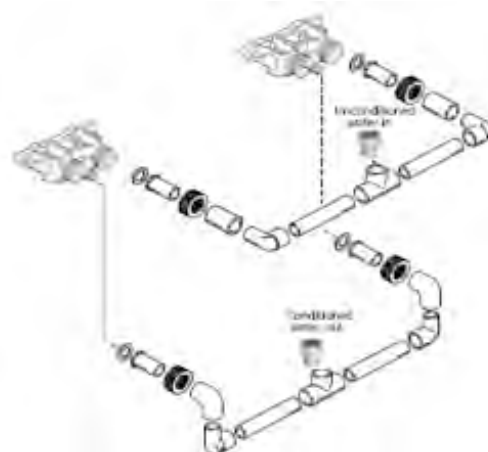

REF.

AV119

Autotrol Valves Series 263 – 268 – 278 Accessories



1265 bypass Kits

- special manifold for AUTOTROL valves series 263, 268 and 278;
- with gaskets, brass adapters and nuts.

REF.	IN/OUT CONNECTIONS	
AV039	1"	
AV040	1 1/4"	

Ref. AV039



Ref. AV040

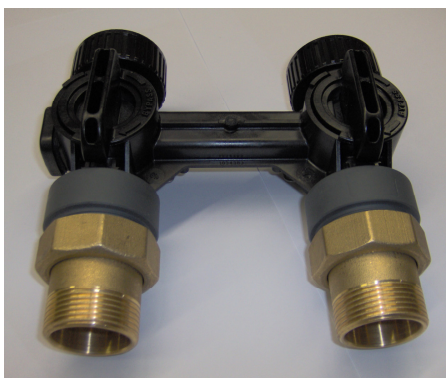

Manifold Kits

- special manifold for AUTOTROL valves series 263, 268 and 278;
- with 2 gaskets, 2 adapters and 2 nuts.

REF.	IN/OUT CONNECTION	MATERIAL ADAPTERS	
AV030B	3/4"	BRASS	
AV031B	1"	BRASS	
AV032	D.32	PVC	
AV038	1 1/4"	BRASS	

Ref. AV031B





D. 32 interconnection kit for 278/764twin residential duplex systems

- special manifold for AUTOTROL 278 valves included;
- for twin alternating and twin parallel systems;
- with IN/OUT connection D.32;
- consisting of:

Q.TY	DESCRIPTION
2	Adapter PVC-U D = 32mm - 1"
2	Tee connection PVC-U D = 32 mm
4	Elbow PVC-U D = 32 mm D1 = 25 mm
4	Tube PVC-U D = 32 mm
2	Elbow D = 32 mm
2	Coupling sleeve D = 32 mm
2	Manifold kit with adapter D. 32 to glue
2	1265 by-pass with o-rings, screws and nuts

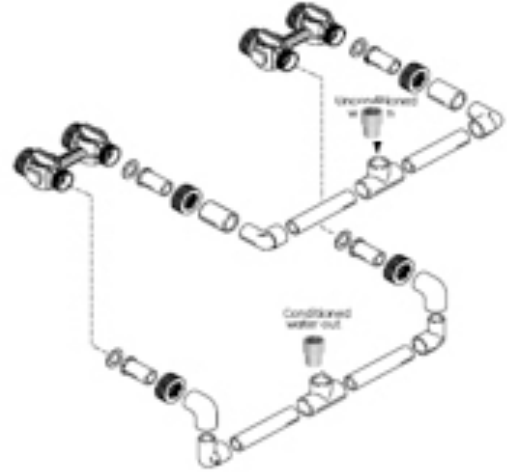

REF.	
AV128	

D. 40 interconnection kit for 278/764twin residential duplex systems

- special manifold for AUTOTROL 278 valves included;
- for twin alternating and twin parallel systems;
- with IN/OUT connection D.40;
- consisting of:

Q.TY	DESCRIPTION
2	Adapter PVC-U D = 40mm - 1 1/4"
2	Tee connection PVC-U D = 40 mm
4	Reducing socket PVC-U D = 40 mm D2 = 32 mm
4	Elbow PVC-U D = 32 mm D1 = 25 mm
4	Tube PVC-U D = 32 mm
2	Elbow D = 32 mm
2	Coupling sleeve D = 32 mm
2	Manifold kit with adapter D. 32 to glue
2	1265 by-pass with o-rings, screws and nuts

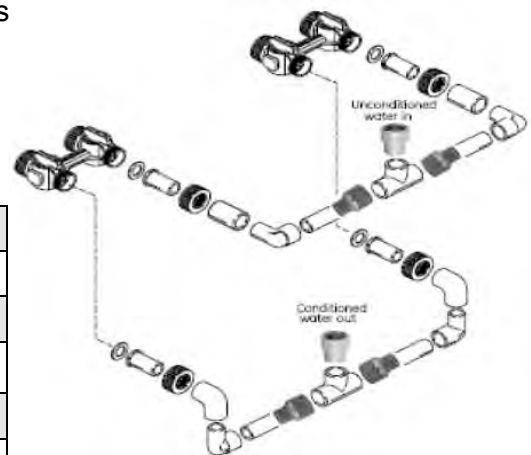

REF.	
AV129	

Autotrol Valves Magnum Accessories



Magnum side mounting adapters

- in PVC material

REF.	CONNECTIONS	
CC084	2" BSPT Female	
CC084A	D.63 Male to glue	



Manifold kits

- with 3 nuts, 3 gaskets and 3 adapters.

REF.	IN/OUT CONNECTION	MATERIAL ADAPTER	FOR AUTOTROL VALVE	
CC080	1 1/2" BSPT	STAINLESS STEEL	MAGNUM CV 1,5" SERIES	
CC081	D.50	PVC	MAGNUM CV 1,5" SERIES	
CC082	2" BSPT	STAINLESS STEEL	MAGNUM IT 2" SERIES	
CC083	D.63	PVC	MAGNUM IT 2" SERIES	

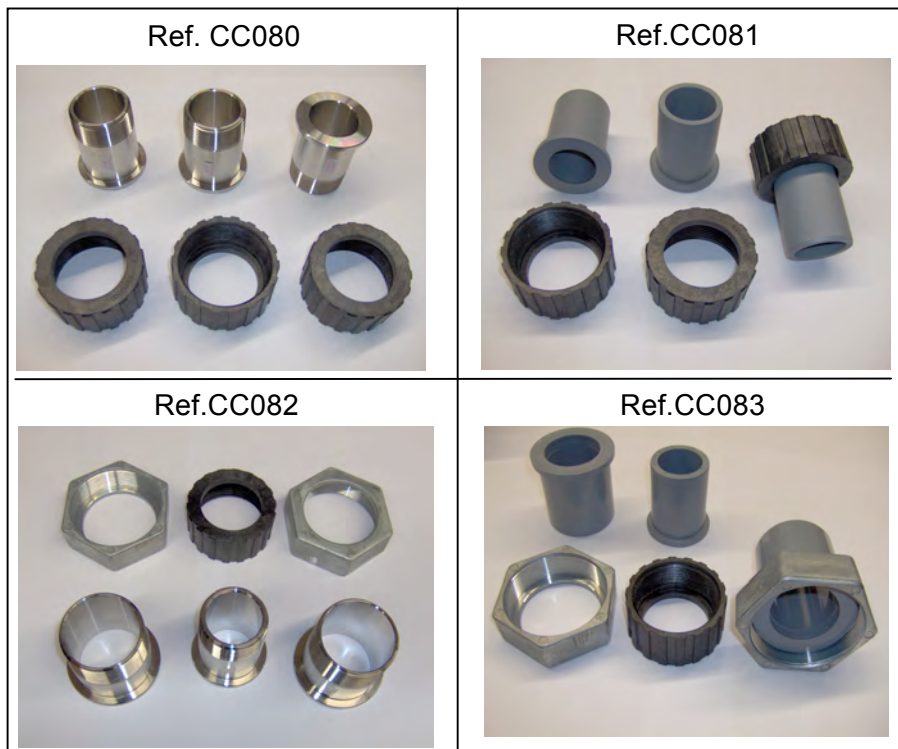



Blending kit for Autotrol valves

- kit of nut and screw to install on 255 and 268 valves for blending of hard and softened water;
- insert the nut into the blending valve orifice located near the bypass flapper (fig.1). Insert the screw through the top plate and the nut, and the screw until it touch the bypass flapper (fig.2);
- tightening the screw will force the bypass flapper open witch will blend hard water into the softened water supply (fig. 3). Loosening the screw will allow the bypass flapper to close reducing the blending;
- test the water and adjust the screw until the desired hardness level is reached.

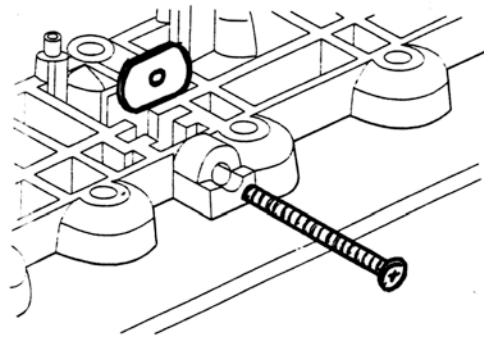

Fig. 1

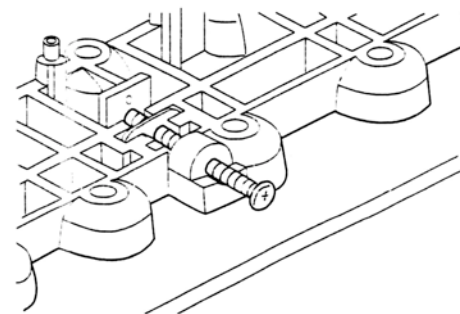

Fig. 2

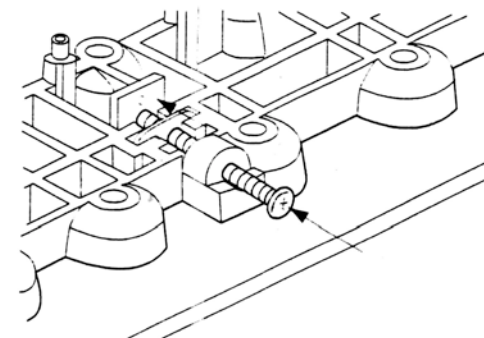

Fig. 3

REF.	DESCRIPTION	
AV037	Kit for 255-268-278 valves	
AV185	Kit for 366-367 valves	



Twist lock upper screens

- in ABS;
- max diameter 60 mm, length 64 mm;
- slots 0,3 mm.

REF.	FOR TUBE (inch)	FOR AUTOTROL VALVE	
AV070	$\frac{13}{16}$ "	255	
AV071	1,05"	255, 263, 268	



Upper screen

- in ABS;
- max diameter 60 mm, length 64 mm;
- slots 0,3 mm.

REF.	FOR TUBE (inch)	
AV072	$\frac{13}{16}$ "	
AV073	1,05"	



Upper screens to glue

- in ABS;
- diameter 88 mm;
- slots 0,3 mm.

REF.	LENGTH (mm)	FOR TUBE (mm)	FOR AUTOTROL VALVE	
CF010	98	41,8 (1 ¼")	180 old model	
CF013	98	48,3	180 new model	
CC050	150	48,3	Magnum	
PV407	150	41,8 (1 ¼")	Adapter 4" PV402	





Fittings for valves

- elbow fittings for $\frac{3}{8}$ " tubing;
- material PP.

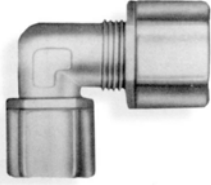

REF.	THREADED CONNECTION (inch)	FOR AUTOTROL VALVE	
AV150	$\frac{1}{4}$ " F	255	
AV154	$\frac{3}{8}$ " F	168 – 268 366 – 367	

Fittings for valves

- straight fittings for $\frac{3}{8}$ " tubing;
- material PP.

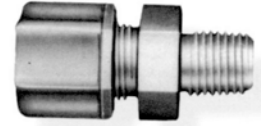

REF.	THREADED CONNECTION (inch)	
AV161	$\frac{1}{8}$ " M	
AV152	$\frac{1}{4}$ " M	
AV153	$\frac{3}{8}$ " M	

- elbow fittings for $\frac{3}{8}$ " tubing;
- material PP.

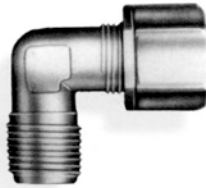

REF.	THREADED CONNECTION (inch)	FOR AUTOTROL VALVE	
AV151	$\frac{1}{4}$ " M	155	
AV159	$\frac{3}{8}$ " M	-	

- bulkhead union for $\frac{3}{8}$ " tubing;
- material PP.

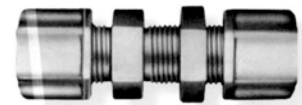

REF.	
AV156	

- Union elbow for $\frac{3}{8}$ " tubing;
- material PP.



REF.	
AV155	

- union TEE for $\frac{3}{8}$ " tubing;
- material PP.



REF.	
AV158	



Barbed drain fittings – overflow

Straight drain fittings

- suitable for flexible hose 12,7 mm internal diameter;
- material nylon.

REF.	CONNECTION	
AV170	3/8" M	
AV171	1/2" M	
AV169	1/2" F	

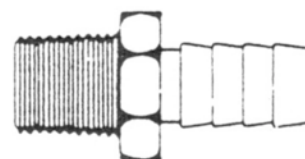

Elbowed drain fittings

- suitable for flexible hose 12,7 mm internal diameter;
- material nylon / polyethylene.

REF.	CONNECTION	
AV172	3/8" M	
AV173	1/2" M	
AV174	1/2" F	
AV175	3/4" F	

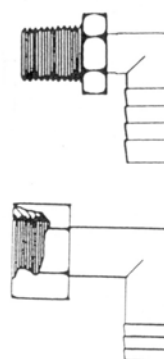

Overflow elbows with nut

- material nylon.

REF.	THREADED CONNECTION	FOR HOSE INT. Ø (MM)	
AV180	3/8"	12,7	
AV181	1/2"	15,5	

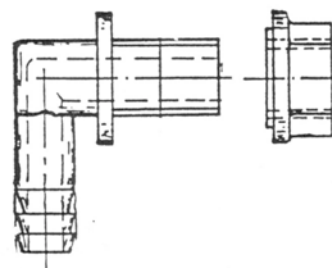



Pvc tubes to glue

- for lower diffusors and lower lateral systems;
- to glue;
- in PVC.

REF.	DIAMETER (inch)	DIAMETER (mm)	LENGTH (mm)	
AV083	1 ³ / ₁₆ "	20,6	890	
AV084	1 ³ / ₁₆ "	20,6	1400	
AV087	1,05"	26,7	1830	
CF012	1 1/4"	41,8	2000	
CC052	1 1/2"	48,3	2000	



Diffusors with tube

- 1,05" hi-flow lower diffuser;
- PVC tube included;
- slots 0,3 mm.

REF.	TUBE LENGTH (inch)	
AV116	17"	
AV117	35"	
AV103	55"	
AV104	72"	





Lower diffusors to glue

- lower diffusors in ABS;
- max diameter 60 mm;
- slots 0,3 mm;
- connection to glue.

REF.	FOR TUBE (inch)	LENGTH (mm)	FLOW (lpm) Δp 30 mbar	
AV098	1 ³ / ₁₆ "	70	24	
AV098A	1,05"	80	32	
AV097	1,05"	90 high flow	40	



Cylindrical lower diffusors

- cylindrical lower diffuser in ABS, diameter 88 mm;
- slots 0,3 mm;
- connection to glue.



ITEM	REF.	LENGTH (mm)	DIFFUSOR LENGTH (mm)	FOR AUTOTROL VALVE	
1	PV315	72	26,7 (1,05")	PERFORMA	
1	CF011	98	41,8 (1 1/4")	180 old model – PV402	
1	CF014	98	48,3	180 new model	
2	CC051	150	48,3	Magnum	

Segmented lower diffusors

- segmented lower diffuser in ABS;
- diameter 66 mm;
- length 102 mm;
- slots 0,3 mm;
- to glue on tube 1,05";
- flow = 50 lpm @ Δp 30 mbar.



REF.	
AV099A	



Lower lateral systems for top mounted valves

- for top mounted valves;
- ABS material;
- slots 0,3 mm;
- hub connection to glue.

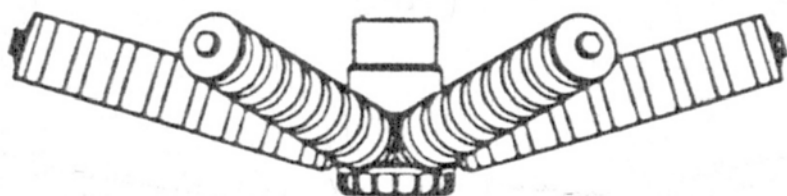

REF.	USEFUL FOR VESSEL (inch)	HUB CONNECT FOR TUBE (mm)	FOR AUTOTROL VALVE	
PV316	14" - 16"	26,7 (1,05")	PERFORMA	
PV317	18" - 21" - 24"	26,7 (1,05")	PERFORMA	
PV318	14" - 16"	41,8 (1 ¼")	180 old model - PV402	
PV319	18" - 21" - 24"	41,8 (1 ¼")	180 old model - PV402	
PV320	14" - 16"	48,3	MAGNUM	
PV321	18" - 21" - 24"	48,3	MAGNUM	
PV322	30"	48,3	MAGNUM	
PV323	36"	48,3	MAGNUM	



Diffusor for brine draw

- connection for rigid or flexible tube $\frac{3}{8}$ ".



REF.	
AV118	

Mesh type screen with tube

- mesh type screen for brine complete with $\frac{3}{8}$ " PVC tube length 42".



REF.	
AV090	

Mesh type screen for brine

- for $\frac{3}{8}$ " tube to glue.

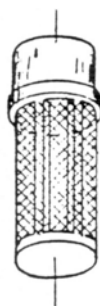

REF.	
AV075	

Polyethylene flexible tube

- flexible tube $\frac{3}{8}$ " (= 9,52 mm) diameter;
- transparent;
- hanks of 30 m.



REF.	
AV140	



J-tube air-check with tube

- J-tube with air-check, complete with PVC tube.

REF.	TUBE DIAMETER (inch)	LENGTH (mm)	
AV093	$\frac{3}{8}$ "	1060	
CC064	$\frac{3}{4}$ "	1200	



Model 464

- model 464 Standard version (for no timed refill controls) and High Flow (for timed refill controls);
- connection for 3/8" tubing;
- length tube 42" (1060 mm);
- length float rod 600 mm;
- brine draw rate 3,8 l/min @ 152 mm Hg vacuum;
- max operating pressure 8,5 bar @ 40°C;
- brine well diameter 90 mm min.

REF.	MODEL	Refill flow rate (l/min) @ 3,5 bar	
AV096	464 Standard	1,3	
AV125	464 High Flow	3,8	

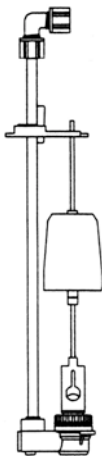

Model 454 Standard

- complete with 3/4" tube length 1200 mm;
- length float rod 915 mm;
- refill flow rate 5 l/min @ 3,5 bar;
- brine draw rate 18 l/min @ 63,5 mm Hg vacuum;
- max operating pressure 8,5 bar @ 40°C;
- brine well diameter 130 mm.

REF.	
CF016	

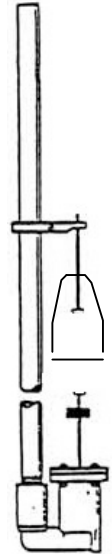

Model 454 High Flow

- complete with 3/4" tube length 1200 mm;
- length float rod 915 mm;
- refill flow rate 15 l/min @ 0,125 bar;
- brine draw rate 30 l/min @ 178 mm Hg vacuum;
- max operating pressure 8,5 bar @ 40°C;
- brine well diameter 130 mm.

REF.	
CC060	

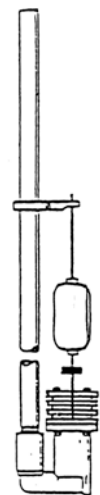



Heads for tank

- PVC heads for tank complete with NBR o-ring;
- max operating pressure 8 bar;
- max operating temperature 25°C;
- REF. PV400 and REF. PV401 are to use with upper screen REF. AV073 (see 01-04-05.02-EN data sheet) and with lower diffusers on catalogue (see 01-04-05.06-EN data sheet);
- REF. PV402 is to use with upper screen REF. PV407 (see 01-04-05.02-EN data sheet) and with lower diffusor REF. CF011 (see 01-04-05.06-EN data sheet).

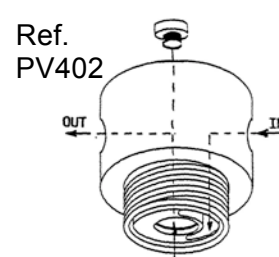
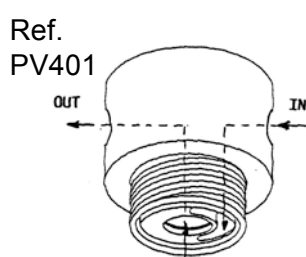
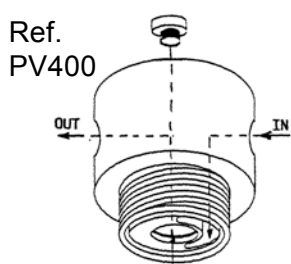

REF.	IN / OUT CONNECTION	OPTION PLUG	RISER TUBE DIAMETER	MAX FLOW RATE SUGGESTED	FIT THREADED TANKS
PV400	3/4" GAS	1/2" on outlet	1,05"	2,5 m ³ /h	2 1/2" – 8NPSM
PV401	3/4" GAS	no plug	1,05"	2,5 m ³ /h	2 1/2" – 8NPSM
PV402	1 1/4" GAS	1/2" on outlet	1 1/4"	6,0 m ³ /h	4" – 8UN

- PP molded heads for tank with connection threaded 2 1/2" – 8NPSM;
- complete with NBR o-ring;
- without plug;
- max operating pressure 8 bar;
- max operating temperature 45°C; it is to use with upper screen REF. AV070 (see 01-04-05.02-EN data sheet) and with lower diffusor REF. AV098 (see 01-04-05.06-EN data sheet).



REF.	IN / OUT CONNECTION	RISER TUBE DIAMETER	MAX SUGGESTED FLOW RATE
PV409	3/4" NPT	13/16"	2,5 m ³ /h



Multi-way Manual Valve

- Multi-way valve having three functions: filtration, backwash, rinse;
- Fits threaded tanks 2 1/2" – 8NPSM;
- IN/OUT connections and drain 1" BSPP female;
- Riser tube diameter 1,05" (26,7 mm);
- Max suggested flow 4 m³/h (only valve);
- Max operating pressure 6 bar @ 20°C;
- Max operating temperature 50°C;
- Upper screen included.

ATTENTION: this multi-way valve is prohibited to change working position with pressure; make sure to shut down pump or close feed valve before rotating the handle to other working position.



REF.	
PV410	

Conductivity Meter Resilight

- positive, reliable and economical method of monitoring water quality via conductivity;
- bright green/red visual output easy to read:
 - Green: conductivity below the threshold value;
 - Red: conductivity above the threshold value;
 - set point conductivity adjustable from 1,5 to 200 microsiemens;
- probe with threaded 3/8" connection, probe constant K=5;
- with reduction in PVC M/F 1/2" x 3/8";
- complete with transformer 230/5V - 50 Hz and 1,5 m cable;
- for installation on piping at system outlet, or directly on the heads REF. PV400 and REF. PV402 (see 01-04-05.10-EN data sheet).

ATTENTION: for greatest accuracy it is required that the water be flowing on probe.

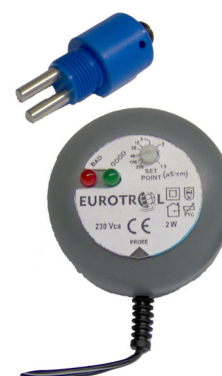

REF.	
PV425	

Chlorogen Chlorin Generator

- positive, reliable and economical method of chlorine generation;
- n.1 Titanium Probe for chlorine generation, n.1 TEE 3/8" connection and n.2 Jaco straight fitting for 3/8" x 3/8" tube included;
- bright green/yellow visual output easy to read:
 - Green: the system is on;
 - Yellow: the system is working in disinfection;
- with time generation adjust;
- 230V - 50 Hz power supply and 1,8 m cable.



REF.	
AX210	



Test kit for hardness

- kit for hardness testing with indicator and titrant complete with test tube;
- definition 0,5 °F;
- number of tests 400°F;
- available No 6 blister of indicator 15 ml (REF. AV203) and No 6 blister of titrant 25 ml (REF. AV204).

REF.	PRICE EURO
AV200	
AV203	
AV204	



- kit for hardness testing with single reagent packaged in blister, with test tube;
- available for definition with French (REF. AV202) or German (REF. AV207) degrees.

REF.	DEFINITION	NUMBER OF TESTS	
AV202	1°F	700°F	
AV207	1°D	600°D	



- kit for hardness testing with single reagent packaged in blister, with test tube;
- available for definition with French (REF. AV201) or German (REF. AV206) degrees.

REF.	DEFINITION	NUMBER OF TESTS	
AV201	1°F	350°F	
AV206	1°D	300°D	





Chlorine generator suitable for valve 255 and Performa 268 with Logix 740/760 and 742/762 controller

- Simple, reliable and cheap disinfection device;
- Delivery includes n.1 electrode and n.1 connection cable;
- Logix 740/760 and 742/762 controllers provide to make a low chlorine level in order to sanitize resin bed during regeneration;
- Logix controller has a light check salt that indicates to end user when salt has to be added into brine tank;
- Potassium chloride or sodium chloride can be used.

REF.	
AX040	

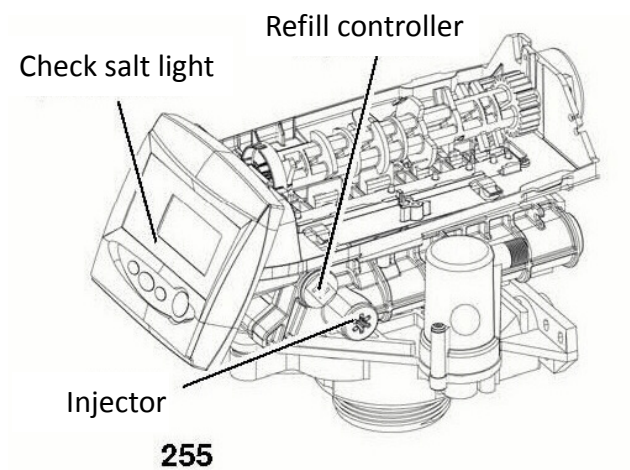

Chlorine generator connection

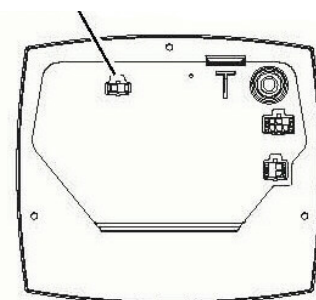
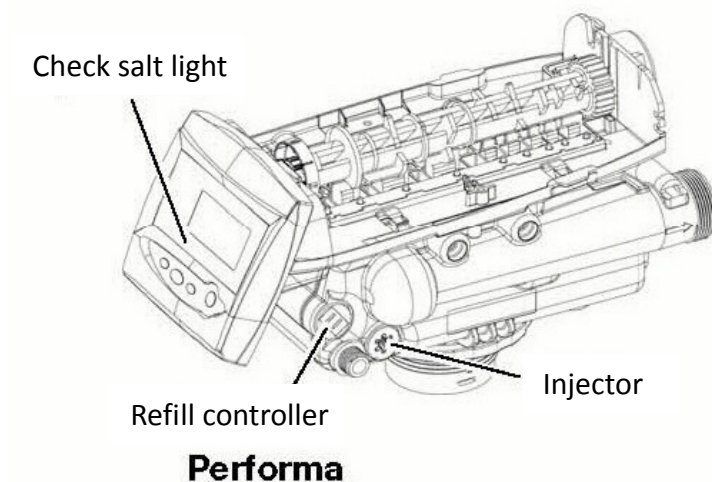

Logix controller - Rear

F65B1 Runxin Residential Chronometric Valve



- Electronic chronometric programmable valve, suitable for automatic and residential water softening systems;
- Valve body in NSF listed Noryl plastic material;
- Operating system based on two high design ceramic discs;
- Operating flow rate $K_v = 1,08$;
- Backwash flow rate $K_v = 0,53$;
- Resin volume range = $5 \div 40$ liters;
- With European transformer 12/230V – 50Hz, upper screen and fittings and Spare Parts Kit (consisting in n.1 Base Seal O-ring, n.1 Drain Hose Connector, n.1 Brine Tube Hose Connector, n.1 Tube Bushing and n.1 red Brine Line Flow Control);
- The others accessories (e.g. lower diffusers and by-pass) are not included.



REF.

RF65B1

Characteristics	
In / Out connections	Threaded $\frac{3}{4}$ " female (male optional included)
Pressure vessel connection	Threaded 2 $\frac{1}{2}$ " - 8 UN male
Brine line connection	Threaded $\frac{3}{8}$ " BSPT male
Distributor tube O. D. diameter	1,05" (= 27 mm)
Distributor tube length above pressure vessel	0 ± 2 mm
Weight (valve + controller)	1,66 kg

F65B1 Runxin Residential Chronometric Valve



Pressure Drop Diagram

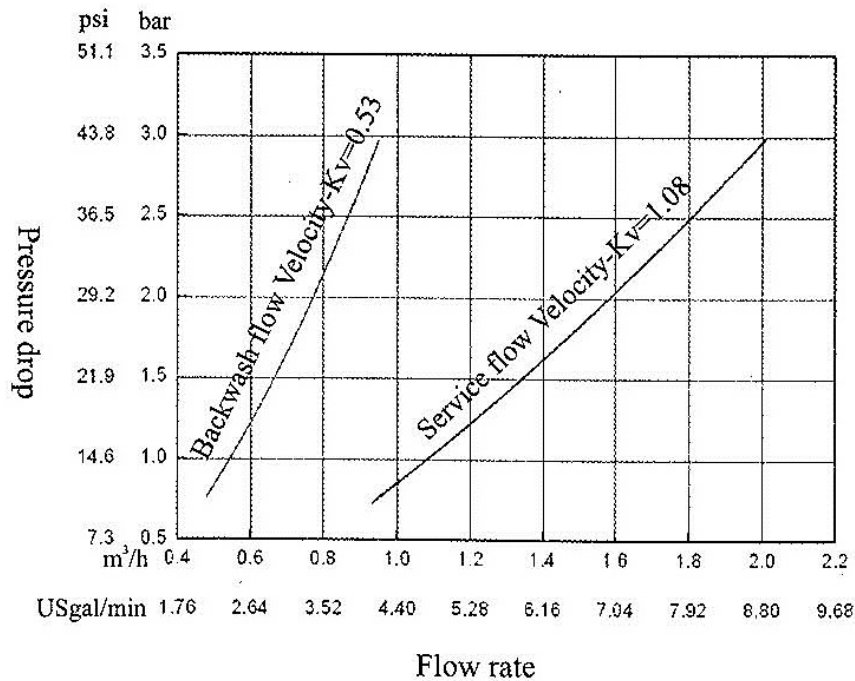

Recommended Operating Conditions	
Operating pressure	1,4 ÷ 5,9 bar
Water temperature	5°C ÷ 45°C

REF.	DESCRIPTION
RF65B1	Runxin Electronic Chronometric Valve

ACCESSORIES

REF.	DESCRIPTION
RF70B	By-pass for RF65B1 Valve
RF47010	Runxin Chlorine Generator
RF09998	2.5" M/F Adapter with O-ring
RF09997	RF09998 Adapter Wrench

F79B-LCD Runxin Residential Volumetric Valve



- Electronic volumetric programmable valve, suitable for automatic and residential water softening systems;
- Valve body in NSF listed Noryl plastic material;
- Operating system based on two high design ceramic discs;
- Operating flow rate $K_v = 1,14$;
- Backwash flow rate $K_v = 0,5$;
- Resin volume range = $5 \div 40$ liters;
- With European transformer 12/230V – 50Hz, upper screen and fittings and Spare Parts Kit (consisting in n.1 Base Seal O-ring, n.1 Drain Hose Connector, n.1 Brine Tube Hose Connector, n.1 Tube Bushing and n.1 red Brine Line Flow Control), Meter and Bypass Adjusting Bolt;
- The others accessories (e.g. lower diffusers and by-pass) are not included.



REF.

RF79B-LCD

Characteristics	
In / Out connections	Threaded $\frac{3}{4}$ " male
Pressure vessel connection	Threaded $2 \frac{1}{2}$ " - 8 UN male
Brine line connection	Threaded $\frac{3}{8}$ " BSPT male
Distributor tube O. D. diameter	1,05" (= 27 mm)
Distributor tube length above pressure vessel	0 ± 2 mm
Weight (valve + controller)	2,25 kg

F79B-LCD Runxin Residential Volumetric Valve



Pressure Drop Diagram

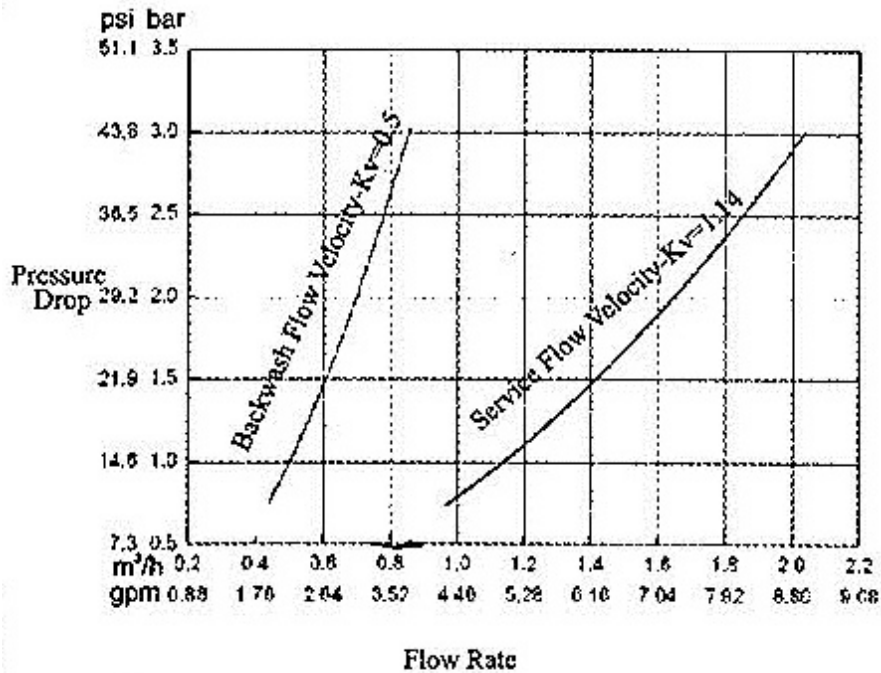

Recommended Operating Conditions	
Operating pressure	1,4 ÷ 5,9 bar
Water temperature	5°C ÷ 45°C

REF.	DESCRIPTION
RF79B-LCD	Runxin Electronic Volumetric Valve

ACCESSORIES

REF.	DESCRIPTION
RF70D	By-pass for RF79B-LCD Valve
RF47010	Runxin Chlorine Generator
RF09998	2.5" M/F Adapter with O-ring
RF09997	RF09998 Adapter Wrench



Pressure
vessels and
accessories



MWG Residential Pressure Vessels with Base



- Made in China;
- composite pressure vessels PE liner reinforced with fiberglass and epoxy resin;
- for industrial and potable water treatment systems;
- European 97/23/EC Directive compliant for pressure equipment (PED);
- certification for contact with drinking water following EC directives;
- D.M. n.174 dated 06/04/2004 compliant about materials suitable for contact with water for human consumption;
- max operating pressure 10 bar;
- max operating temperature 50 °C;
- top connection threaded 2 ½" – 8NPSM or 4"– 8UN;
- cycle test 250.000 times from 0,7 to 10 bar;
- burst test to 4 times max operating pressure;
- blue colour;
- warranty 5 years.

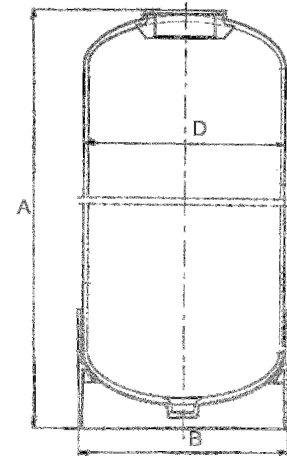

REF.	MODEL	VOLUME (liters)	EXTERNAL D (mm)	A (mm)	B (mm)	CONNECTION	
BMWG06013BB	6 x 13	4,6	155	335 ± 6	165	2 ½"	
BMWG06018BB	6 x 18	7,1	155	460 ± 6	165	2 ½"	
BMWG06035BB	6 x 35	13,7	155	892 ± 6	165	2 ½"	
BMWG07013BB	7 x 13	6,3	180	333 ± 6	188	2 ½"	
BMWG07017BB	7 x 17	8,6	180	434 ± 6	188	2 ½"	
BMWG07024BB	7 x 24	13,2	180	620 ± 6	188	2 ½"	
BMWG07030BB	7 x 30	16,4	180	780 ± 6	188	2 ½"	
BMWG07035BB	7 x 35	20,1	180	891 ± 6	188	2 ½"	
BMWG08013BB	8 x 13	8,5	207	332 ± 6	216	2 ½"	
BMWG08017BB	8 x 17	10,9	207	433 ± 6	216	2 ½"	
BMWG08024BB	8 x 24	15,9	207	621 ± 6	216	2 ½"	
BMWG08030BB	8 x 30	20,9	207	767 ± 6	216	2 ½"	
BMWG08035BB	8 x 35	25,0	207	892 ± 6	216	2 ½"	
BMWG08044BB	8 x 44	32,1	207	1124 ± 6	216	2 ½"	
BMWG09017BB	9 x 17	13,8	231	450 ± 6	240	2 ½"	
BMWG09030BB	9 x 30	26,9	231	785 ± 6	240	2 ½"	
BMWG09035BB	9 x 35	32,1	231	894 ± 6	240	2 ½"	
BMWG09042BB	9 x 42	38,4	231	1070 ± 6	240	2 ½"	
BMWG09048BB	9 x 48	44,4	231	1221 ± 6	240	2 ½"	
BMWG10017BB	10 x 17	16,7	258	439 ± 6	268	2 ½"	
BMWG10019BB	10 x 19	19,3	258	490 ± 6	268	2 ½"	
BMWG10024BB	10 x 24	25,2	258	620 ± 6	268	2 ½"	
BMWG10030BB	10 x 30	33,0	258	774 ± 6	268	2 ½"	
BMWG10035BB	10 x 35	39,4	258	896 ± 6	268	2 ½"	
BMWG10044BB	10 x 44	51,2	258	1128 ± 6	268	2 ½"	
BMWG10047BB	10 x 47	54,1	258	1191 ± 6	268	2 ½"	
BMWG10054BB	10 x 54	63,3	258	1387 ± 6	268	2 ½"	
BMWG10054GB	10 x 54	63,3	258	1387 ± 6	268	4"	
BMWG12048BB	12 x 48	89,0	310	1234 ± 6	318	2 ½"	
BMWG12052BB	12 x 52	97,0	310	1334 ± 6	318	2 ½"	
BMWG13044BB	13 x 44	86,8	335	1118 ± 6	343	2 ½"	
BMWG13054BB	13 x 54	105,3	335	1375 ± 6	343	2 ½"	
BMWG13054GB	13 x 54	105,3	335	1375 ± 6	343	4"	

Park Residential Pressure Vessels with Base



- Made in European Union (Belgium);
- composite pressure vessels PE liner reinforced with fiberglass and epoxy resin;
- for industrial and potable water treatment systems;
- European 97/23/EC Directive compliant for pressure equipment (PED);
- certification for contact with drinking water following EC directives and KTW recommendations;
- D.M. n.174 dated 06/04/2004 compliant about materials suitable for contact with water for human consumption;
- max operating pressure 10 bar;
- max operating temperature 50°C;
- top connection threaded 2 ½" – 8NPSM or 4" – 8UN;
- cycle test 250.000 times from 0,7 to 10 bar;
- burst test to 4 times max operating pressure;
- blue colour;
- warranty 5 years.

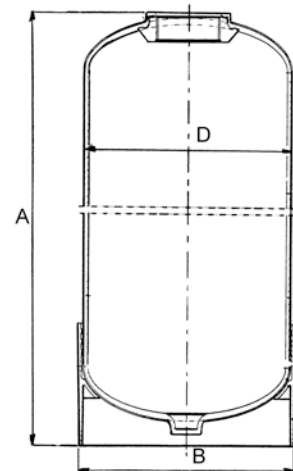

REF.	MODEL	VOLUME (liters)	EXTERNAL D (mm)	A (mm)	B (mm)	CONNECTION	
B06013BB	6 x 13	4,6	159	342 ± 2	170	2 ½"	
B06018BB	6 x 18	6,9	159	475 ± 2	170	2 ½"	
B06035BB	6 x 35	14,4	159	907 ± 2	170	2 ½"	
B07013BB	7 x 13	6,3	184	341 ± 2	195	2 ½"	
B07017BB	7 x 17	8,8	184	446 ± 2	195	2 ½"	
B07024BB	7 x 24	13,5	184	613 ± 2	195	2 ½"	
B07030BB	7 x 30	16,8	184	778 ± 2	195	2 ½"	
B07035BB	7 x 35	20,4	184	901 ± 2	195	2 ½"	
B08013BB	8 x 13	8,2	208	347 ± 2	220	2 ½"	
B08017BB	8 x 17	11,0	208	435 ± 2	220	2 ½"	
B08024BB	8 x 24	16,6	208	612 ± 4	220	2 ½"	
B08030BB	8 x 30	22,0	208	783 ± 2	220	2 ½"	
B08035BB	8 x 35	25,7	208	902 ± 2	220	2 ½"	
B08044BB	8 x 44	33,6	208	1124 ± 2	220	2 ½"	
B09017BB	9 x 17	13,7	233	431 ± 4	240	2 ½"	
B09024BB	9 x 24	20,4	233	612 ± 4	240	2 ½"	
B09030BB	9 x 30	26,6	233	766 ± 5	240	2 ½"	
B09035BB	9 x 35	31,3	233	903 ± 2	240	2 ½"	
B09042BB	9 x 42	38,2	233	1074 ± 5	240	2 ½"	
B09048BB	9 x 48	44,6	233	1228 ± 5	240	2 ½"	
B10017BB	10 x 17	16,8	257	436 ± 4	269	2 ½"	
B10019BB	10 x 19	19,1	257	502 ± 2	269	2 ½"	
B10022BB	10 x 22	22,9	257	559 ± 4	269	2 ½"	
B10024BB	10 x 24	25,1	257	605 ± 4	269	2 ½"	
B10030BB	10 x 30	32,4	257	766 ± 4	269	2 ½"	
B10035BB	10 x 35	38,9	257	903 ± 2	269	2 ½"	
B10044BB	10 x 44	48	257	1122 ± 2	269	2 ½"	
B10047BB	10 x 47	54	257	1188 ± 5	269	2 ½"	
B10054BB	10 x 54	61	257	1385 ± 2	269	2 ½"	
B10054GB	10 x 54	62	257	1382 ± 5	269	4"	
B12048BB	12 x 48	76	304	1232 ± 3	315	2 ½"	
B12052BB	12 x 52	84	304	1335 ± 3	315	2 ½"	
B13044BB	13 x 44	85	334	1145 ± 6	330	2 ½"	
B13054BB	13 x 54	103	334	1371 ± 3	330	2 ½"	
B13054GB	13 x 54	103	334	1371 ± 3	330	4"	

MWG Residential Pressure Vessels without Base



- Made in PRC;
- composite pressure vessels PE liner reinforced with fiberglass and epoxy resin;
- for industrial and potable water treatment systems;
- European 97/23/EC Directive compliant for pressure equipment (PED);
- certification for contact with drinking water following EC directives;
- D.M. n.174 dated 06/04/2004 compliant about materials suitable for contact with water for human consumption;
- max operating pressure 10 bar;
- max operating temperature 50°C;
- top connection threaded 2 ½" – 8NPSM or 4" – 8UN;
- cycle test 250.000 times from 0,7 to 10 bar;
- burst test to 4 times max operating pressure;
- blue colour;
- warranty 5 years.

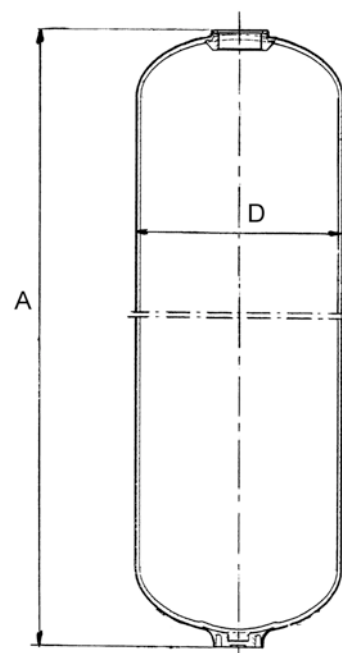

REF.	MODEL	VOLUME (liters)	EXTERNAL D (mm)	A (mm)	CONNECTION (inch)	
BMWG06013AB	6 x 13	5,3	159,5	329 ± 3	2 ½"	
BMWG07013AB	7 x 13	6,8	180	329 ± 3	2 ½"	
BMWG07017AB	7 x 17	9,4	180	431 ± 3	2 ½"	
BMWG07019AB	7 x 19	11,6	180	483 ± 3	2 ½"	
BMWG07024AB	7 x 24	13,8	180	611 ± 3	2 ½"	
BMWG07030AB	7 x 30	17,8	180	771 ± 3	2 ½"	
BMWG07035AB	7 x 35	20,7	180	891 ± 3	2 ½"	
BMWG08013AB	8 x 13	8,8	207	329 ± 3	2 ½"	
BMWG08017AB	8 x 17	12,1	207	431 ± 3	2 ½"	
BMWG08024AB	8 x 24	18,0	207	611 ± 3	2 ½"	
BMWG08030AB	8 x 30	23,2	207	771 ± 3	2 ½"	
BMWG08035AB	8 x 35	27,1	207	891 ± 3	2 ½"	
BMWG09017AB	9 x 17	15,0	230	431 ± 3	2 ½"	
BMWG09024AB	9 x 24	22,3	230	611 ± 3	2 ½"	
BMWG09030AB	9 x 30	28,8	230	771 ± 3	2 ½"	
BMWG09035AB	9 x 35	33,7	230	891 ± 3	2 ½"	
BMWG10017AB	10 x 17	18,4	257,5	431 ± 3	2 ½"	
BMWG10019AB	10 x 19	21,1	257,5	483 ± 3	2 ½"	
BMWG10024AB	10 x 24	27,6	257,5	611 ± 3	2 ½"	
BMWG10030AB	10 x 30	35,8	257,5	771 ± 3	2 ½"	
BMWG10035AB	10 x 35	41,9	257,5	891 ± 3	2 ½"	

Dome-Hole Residential Pressure Vessels



- Made in U.S.A.;
- composite pressure vessels PE liner reinforced with fiberglass and epoxy resin;
- 1 ¼" opening on the dome top of the tank with Noryl plug;
- for industrial and potable water treatment systems;
- European 97/23/EC Directive compliant for pressure equipment (PED);
- certification for contact with drinking water following EC directives and KTW recommendations;
- max operating pressure 10 bar;
- max operating temperature 50°C;
- top connection threaded 2 ½" – 8NPSM;
- cycle test 250.000 times from 0,7 to 10 bar;
- burst test to 4 times max operating pressure;
- natural colour;
- Warranty 5 years.

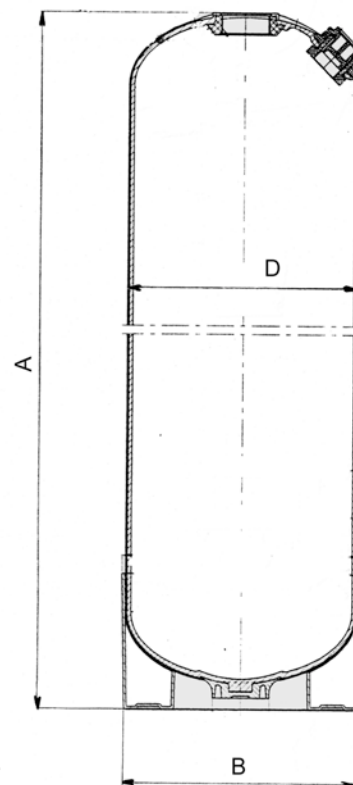

REF.	MODEL	VOLUME (liters)	EXTERNAL D (mm)	A (mm)	B (mm)	CONNECTION (inch)	
B10044QN(*)	10 x 44 DH	48	257	1122	269	2 ½"	
B10054QN(*)	10 x 54 DH	61	257	1378	269	2 ½"	
B12048QN(*)	12 x 48 DH	76	304	1217	315	2 ½"	
B13054QN(*)	13 x 54 DH	103	364	1370	375	2 ½"	

(*) not available in stock.

MWG Industrial Pressure Vessels With Threaded Top Opening



- Made in China;
- composite pressure vessels PE liner reinforced with fiberglass and epoxy resin;
- for industrial and potable water treatment systems;
- European 97/23/EC Directive compliant for pressure equipment (PED);
- certification for contact with drinking water following EC directives;
- D.M. n.174 dated 06/04/2004 compliant about materials suitable for contact with water for human consumption;
- max operating pressure 10 bar;
- max operating temperature 50°C;
- threaded top connection 4"– 8UN;
- cycle test 250.000 times from 0,7 to 10 bar;
- burst test to 4 times max operating pressure;
- blue colour;
- Warranty 5 years.

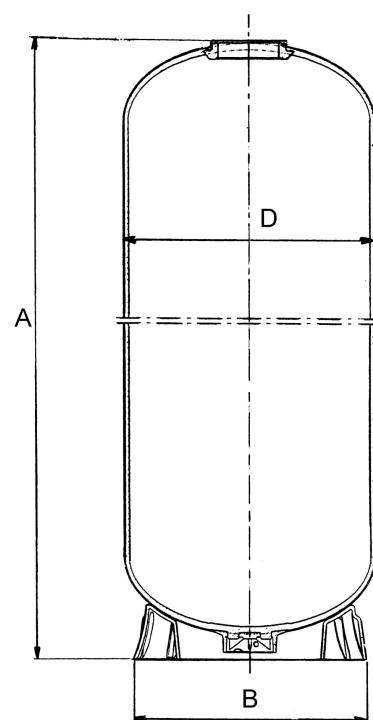

REF.	MODEL	VOLUME (liters)	EXTERNAL DIAMETER (mm)	A (mm)	B (mm)	CONNECTION (inch)	
BMWG14052GB	14 x 52	115,7	360	1325 ± 6	369	4" (**)	
BMWG14065GB	14 x 65	148,5	360	1657 ± 6	369	4" (**)	
BMWG16052GB	16 x 52	153,0	410	1312 ± 6	420	4" (**)	
BMWG16065GB	16 x 65	192,1	410	1648 ± 6	420	4" (**)	
BMWG18053GB	18 x 53	216,5	464	1366 ± 6	450	4"	
BMWG18065GB	18 x 65	268,0	464	1670 ± 6	450	4"	
BMWG21053GB	21 x 53	278,0	540	1390 ± 10	530	4"	
BMWG21062GB	21 x 62	341,0	540	1620 ± 10	530	4"	
BMWG24065GB	24 x 65	419,0	615	1720 ± 10	610	4"	
BMWG24072GB	24 x 72	490,0	615	1900 ± 10	610	4"	
BMWG30072GB (*)	30 x 72	735,0	767	1890 ± 10	750	4"	
BMWG36072GB (*)	36 x 72	1031,0	920	1965 ± 10	930	4"	

(*) Vacuum breaker included.

(**) with reduction 2,5"

Park Industrial Pressure Vessels With Threaded Top Opening



- Made in European Union (Belgium);
- composite pressure vessels PE liner reinforced with fiberglass and epoxy resin;
- for industrial and potable water treatment systems;
- European 97/23/EC Directive compliant for pressure equipment (PED);
- certification for contact with drinking water following EC directives and KTW recommendations;
- D.M. n.174 dated 06/04/2004 compliant about materials suitable for contact with water for human consumption;
- max operating pressure 10 bar;
- max operating temperature 50°C;
- threaded top connection 4"– 8UN;
- cycle test 250.000 times from 0,7 to 10 bar;
- burst test to 4 times max operating pressure;
- blue colour;
- Warranty 5 years.

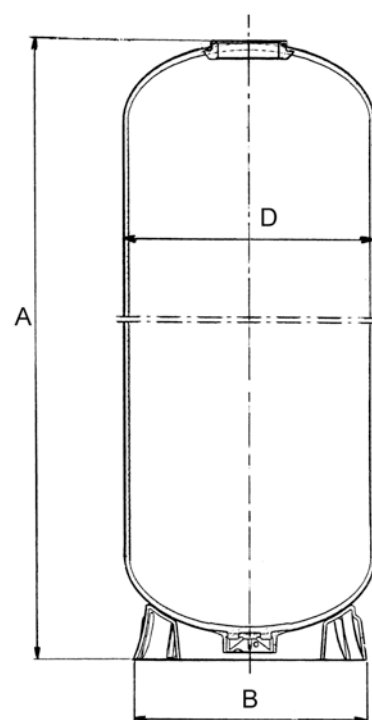

REF.	MODEL	VOLUME (liters)	EXTERNAL DIAMETER (mm)	A (mm)	B (mm)	CONNECTION (inch)	
B14052GB	14 x 52	122	369	1360 ± 20	330	4" (**)	
B14065GB	14 x 65	140	369	1645 ± 20	380	4" (**)	
B16052GB	16 x 52	128	406	1269 ± 20	420	4" (**)	
B16065GB	16 x 65	170	406	1632 ± 20	420	4" (**)	
B18053GB	18 x 53	211	469	1432 ± 20	510	4"	
B18065GB	18 x 65	250	469	1726 ± 20	510	4"	
B21036GB	21 x 36	164	552	1025 ± 20	510	4"	
B21053GB	21 x 53	277	552	1434 ± 20	510	4"	
B21060GB	21 x 60	310	552	1625 ± 20	510	4"	
B24069GB	24 x 69	450	610	1870 ± 20	510	4"	
B30072GB (*)	30 x 72	710	770	2030 ± 30	730	4"	
B36072GB (*)	36 x 72	1020	938	2130 ± 30	730	4"	

(*) Vacuum breaker included.

(**) with reduction 2,5"

MWG Industrial Pressure Vessels With Top&Bottom Threaded Openings



- Made in China;
- composite pressure vessels PE liner reinforced with fiberglass and epoxy resin;
- for industrial and potable water treatment systems;
- European 97/23/EC Directive compliant for pressure equipment (PED);
- certification for contact with drinking water following EC directives;
- D.M. n.174 dated 06/04/2004 compliant about materials suitable for contact with water for human consumption;
- max operating pressure 10 bar;
- max operating temperature 50°C;
- top and bottom threaded connection 4"– 8UN;
- cycle test 250.000 times from 0,7 to 10 bar;
- burst test to 4 times max operating pressure;
- blue colour;
- warranty 5 years.

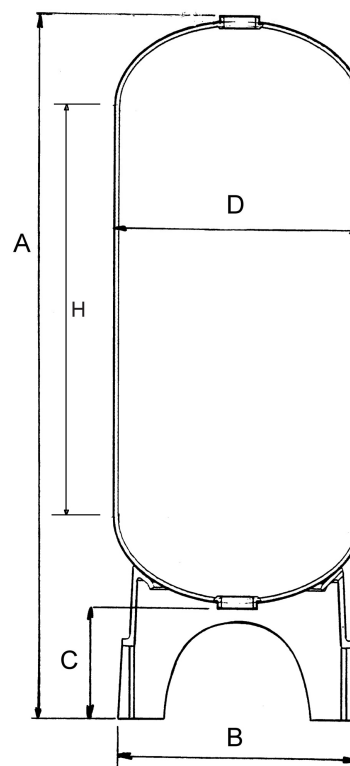

REF.	MODEL	VOLUME (liters)	EXTERNAL DIAMETER (mm)	A (mm)	B (mm)	C (mm)	H (mm)	CONNECTION (inch)	
BMWG14065HB	14 x 65	148,5	360	1856 ± 6	369	230	1386	4"	
BMWG16065HB	16 x 65	192,1	410	1880 ± 6	420	250	1365	4"	
BMWG18065HB	18 x 65	268	464	1950 ± 10	450	320	1330	4"	
BMWG21062HB	21 x 62	340	540	1902 ± 10	530	330	1220	4"	
BMWG24065HB	24 x 65	419	615	1916 ± 10	610	246	1220	4"	
BMWG24072HB	24 x 72	490	615	2090 ± 10	610	240	1400	4"	
BMWG30072HB (*)	30 x 72	735	767	2077 ± 10	750	235	1270	4"	
BMWG36072HB (*)	36 x 72	1031	920	2200 ± 10	930	350	1170	4"	

(*) Vacuum breaker included.

Park Industrial Pressure Vessels With Top&Bottom Threaded Openings



- Made in European Union (Belgium);
- composite pressure vessels PE liner reinforced with fiberglass and epoxy resin;
- for industrial and potable water treatment systems;
- European 97/23/EC Directive compliant for pressure equipment (PED);
- certification for contact with drinking water following EC directives and KTW recommendations;
- D.M. n.174 dated 06/04/2004 compliant about materials suitable for contact with water for human consumption;
- max operating pressure 10 bar;
- max operating temperature 50°C;
- top and bottom threaded connection 4"– 8UN;
- cycle test 250.000 times from 0,7 to 10 bar;
- burst test to 4 times max operating pressure;
- blue colour;
- warranty 5 years.

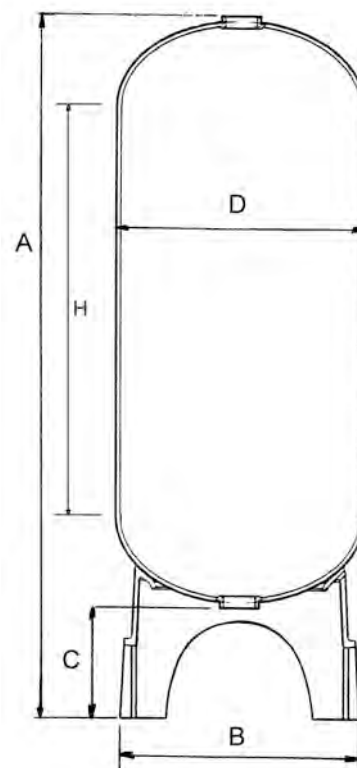

REF.	MODEL	VOLUME (liters)	EXTERNAL DIAMETER (mm)	A (mm)	B (mm)	C (mm)	H (mm)	CONNECTION (inch)	
B14065HB	14 x 65	140	369	2031 ± 20	488	381	1378	4"	
B16065HB	16 x 65	170	406	2031 ± 20	497	384	1371	4"	
B18065HB	18 x 65	245	469	2080 ± 20	554	404	1350	4"	
B21060HB	21 x 60	310	552	1923 ± 20	554	389	1155	4"	
B24069HB	24 x 69	450	610	2169 ± 20	620	422	1327	4"	
B30072HB (*)	30 x 72	712	770	2248 ± 30	816	413	1313	4"	
B36072HB (*)	36 x 72	1080	927	2305 ± 30	1001	408	1266	4"	

(*) Vacuum breaker included.

Park Industrial Pressure Vessels With Flanged Top Opening



- Made in European Union (Belgium);
- composite pressure vessels PE liner reinforced with fiberglass and epoxy resin;
- for industrial and potable water treatment systems;
- European 97/23/EC Directive compliant for pressure equipment (PED);
- certification for contact with drinking water following EC directives and KTW recommendations;
- D.M. n.174 dated 06/04/2004 compliant about materials suitable for contact with water for human consumption;
- max operating pressure 10 bar;
- max operating temperature 65°C;
- 6" top connection;
- cycle test 250.000 times from 0,7 to 10 bar;
- burst test to 4 times max operating pressure;
- blue colour;
- warranty 5 years.

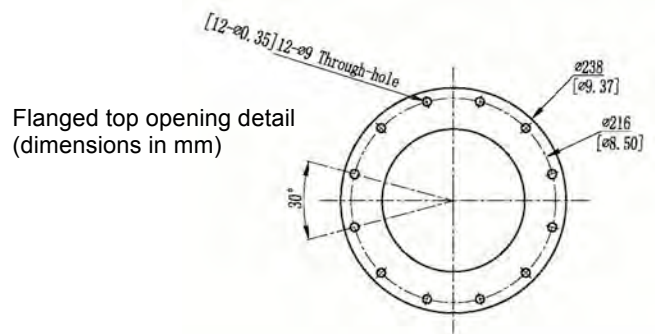
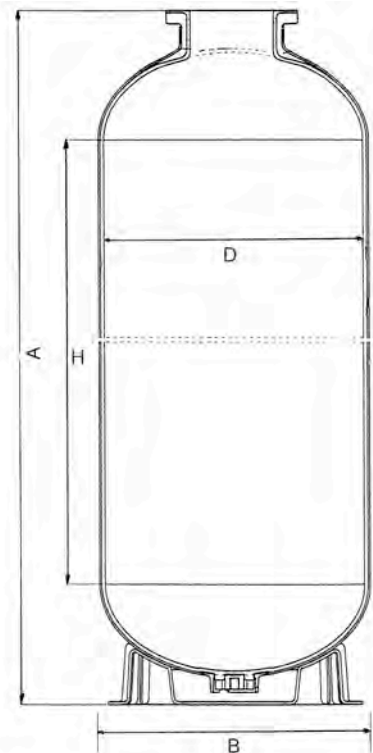

REF.	MODEL	VOLUME (liters)	EXTERNAL DIAMETER (mm)	A (mm)	B (mm)	H (mm)	CONNECTION (inch)	
B18068LB	18 x 68	248	469	1777 ± 20	510	1344	6"	
B21062LB	21 x 62	310	552	1673 ± 20	510	1159	6"	
B24075LB	24 x 75	450	610	1908 ± 20	510	1320	6"	
B30078LB (*)	30 x 78	710	770	2058 ± 30	768	1282	6"	
B36078LB (*)	36 x 78	1020	927	2155 ± 30	768	1235	6"	

(*) Vacuum breaker included.

MWG Industrial Pressure Vessels With Flanged Top&Bottom Openings



- Made in China;
- composite pressure vessels PE liner reinforced with fiberglass and epoxy resin;
- for industrial and potable water treatment systems;
- European 97/23/EC Directive compliant for pressure equipment (PED);
- certification for contact with drinking water following EC directives;
- D.M. n.174 dated 06/04/2004 compliant about materials suitable for contact with water for human consumption;
- max operating pressure 10 bar;
- max operating temperature 65°C;
- top and bottom 6" flange connection;
- cycle test 250.000 times from 0,7 to 10 bar;
- burst test to 4 times max operating pressure;
- blue colour;
- Warranty 5 years.

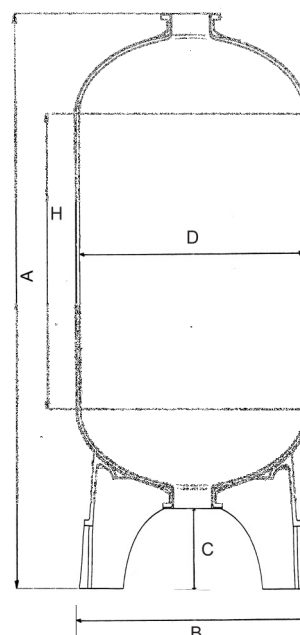

Flanged top opening detail
(dimensions in mm)

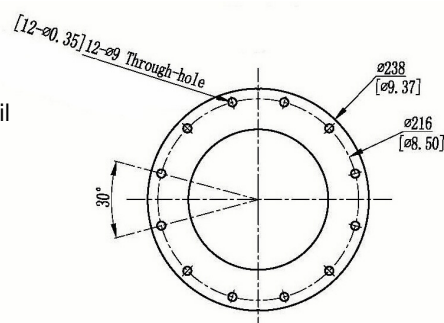

(*) Vacuum breaker included.

REF.	MODEL	VOLUME (liters)	EXTERNAL DIAMETER (mm)	A (mm)	B (mm)	C (mm)	H (mm)	CONNECTIONS (inch)	
BMWG30072MB (*)	30 x 72	735	767	2240 ± 25	770	265	1260	6"	
BMWG36072MB (*)	36 x 72	1031	920	2275 ± 25	930	285	1195	6"	
BMWG42072MB (*)	42 x 72	1461	1088	2315 ± 25	1060	295	1080	6"	
BMWG48072MB (*)	48 x 72	1890	1220	2270 ± 25	1200	260	1110	6"	
BMWG63067MB (*)	63 x 67	2547	1620	2050 ± 25	1580	260	660	6"	
BMWG63086MB (*)	63 x 86	3488	1620	2480 ± 25	1580	260	1100	6"	

Park Industrial Pressure Vessels With Flanged Top&Bottom Openings



- Made in European Union (Belgium);
- composite pressure vessels PE liner reinforced with fiberglass and epoxy resin;
- for industrial and potable water treatment systems;
- European 97/23/EC Directive compliant for pressure equipment (PED);
- certification for contact with drinking water following EC directives and KTW recommendations;
- D.M. n.174 dated 06/04/2004 compliant about materials suitable for contact with water for human consumption;
- max operating pressure 10 bar;
- max operating temperature 65°C;
- top and bottom 6" flange connection;
- cycle test 250.000 times from 0,7 to 10 bar;
- burst test to 4 times max operating pressure;
- blue colour;
- Warranty 5 years.

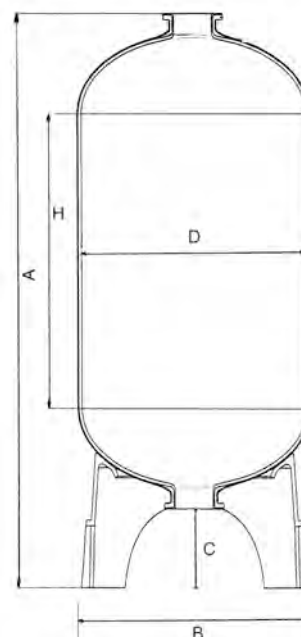

Flanged top opening detail
(dimensions in mm)

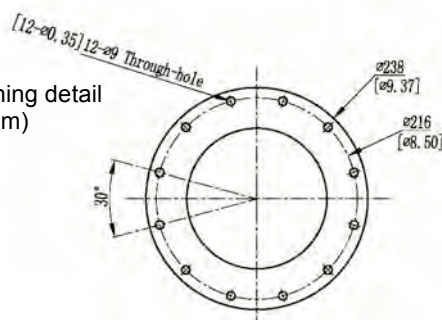

(*) Vacuum breaker included.

REF.	MODEL	VOLUME (liters)	EXTERNAL DIAMETER (mm)	A (mm)	B (mm)	C (mm)	H (mm)	CONN. (inch)	
B18068MB	18 x 68	250	469	2120 ± 20	545	240	1344	6"	
B21066MB	21 x 66	310	552	2010 ± 20	545	368	1158	6"	
B24075MB	24 x 75	450	610	2220 ± 20	620	354	1320	6"	
B30078MB (*)	30 x 78	710	770	2285 ± 30	778	365	1284	6"	
B36078MB (*)	36 x 78	1020	910	2340 ± 30	955	360	1235	6"	
B42063MB (*)	42 x 63	1047	1074	2065 ± 30	1090	440	775	6"	
B42072MB (*)	42 x 72	1360	1074	2415 ± 30	1090	440	1142	6"	
B48072MB (*)	48 x 72	1840	1220	2430 ± 30	1280	400	1135	6"	
B63067MB (*)	63 x 67	2484	1623	2075 ± 30	1575	355	594	6"	
B63086MB (*)	63 x 86	3200	1623	2475 ± 30	1575	355	996	6"	



Adapters

- adapter 4"– 8UN to 2 ½" – 8NPSM;
- with O-ring.

REF.	MODEL	REDUCTION TO	
PV300	PVC lavorato	2 ½" – 8 NPSM	
PV307	PVC lavorato	2" BSP	

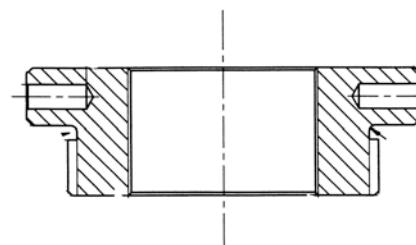

Closures

- closure for 4"– 8UN tanks thread;
- with O-ring.

REF.	MATERIAL	
PV301	PVC machined	

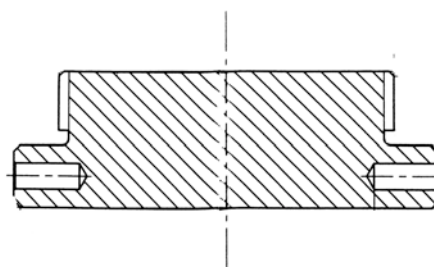

6" closed flange

- 6" closed flange complete with bolts, nuts, washer and O-ring;
- flange material PVC;
- bolts material AISI 304.

REF.	
PV510B	

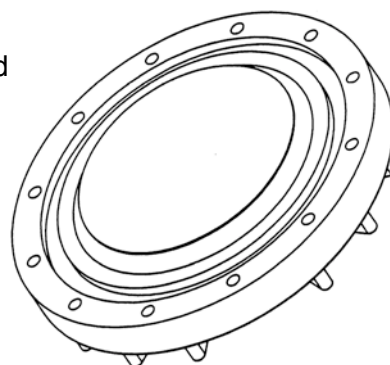



6" - 4" adapter

- 6" flanged adapter 4"-8UN, complete with bolts, nuts, washer and O-ring;
- bolts material AISI 304.

REF.	ADAPTER MATERIAL	
PV511A	PPO	
PV511B	PVC	

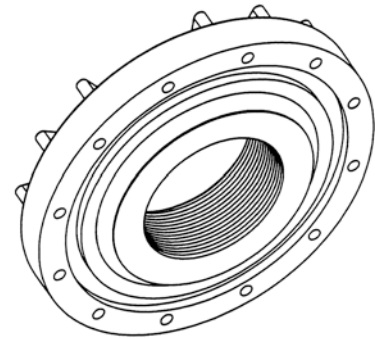

6" - 3" - 3" adapter

- 6" flanged x 3" x 3" BSP threaded adapter complete with bolts, nuts, washer and O-ring.;
- flange material PPO;
- bolts material AISI 304.

REF.	
PV509	

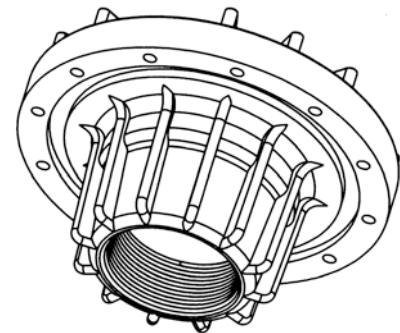

Aeration valve & vacuum breaker

- aeration valve and vacuum breaker in PP;
- connection 1 1/2", drain 1/2";
- max pressure 10 bar;
- max temperature 65°C.

REF.	
PV308	

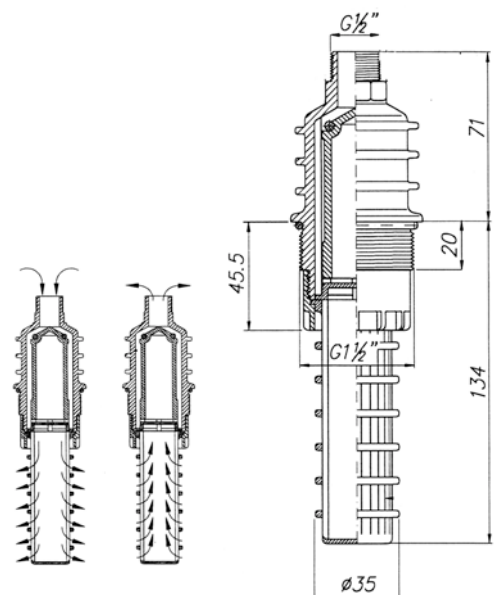



Cylindrical diffusors

- cylindrical diffuser for vessels with 4"- 8UN, for upper or lower installation;
- outlet connection to glue D.63;
- 0,2 mm slots or 0,5 mm;
- materials: adapter PVC, diffuser PP;
- flow 20 m³/h at Dp 0,2 bar;
 - A. union D63 (REF. PV329);
 - B. adapter 4" with O-rings (REF. PV332);
 - C. reduction 2" M/F (REF. PV335);
 - D. diffuser diameter 85 mm length 180 mm.(REF. PV340 0,2 mm slots – REF. PV342 0,5 mm slots).

REF.	SLOTS (mm)	VESSEL	
PV351	0,2	14" ÷ 36"	
PV352	0,5	14" ÷ 36"	

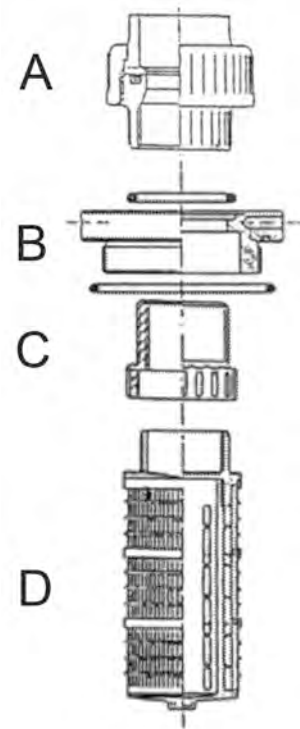

Cylindrical diffusors with elbow

- cylindrical diffuser for vessel 4"-8UN, for upper installation;
- outlet connection with elbow to glue D63;
- 0,2 mm slots or 0,5 mm
- materials: adapter and elbow PVC, diffuser PP;
- flow 20 m³/h at Δp 0,2 bar;
- including:
 - A. elbow D63 (REF. PV331);
 - B. adapter 4"with O-rings (REF. PV332);
 - C. reduction 2" M/F (REF. PV335);
 - D. diffuser con diameter 85 mm length 180 mm (REF.PV340 0,2 mm slots – REF. PV342 0,5 mm slots).

REF.	SLOTS (mm)	VESSEL	
PV350	0,2	14" ÷ 36"	
PV349	0,5	14" ÷ 36"	

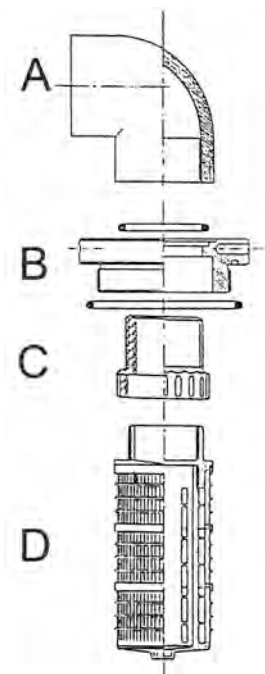



Flanged upper diffusers

- upper diffuser 6" flanged, complete with bolts, nuts, washer and O-ring;
- flange material PVC;
- PP cylindrical diffuser 0,2 mm slots or 0,5 mm slots – see data sheet 02-03-05-EN;
- bolts material AISI 304.

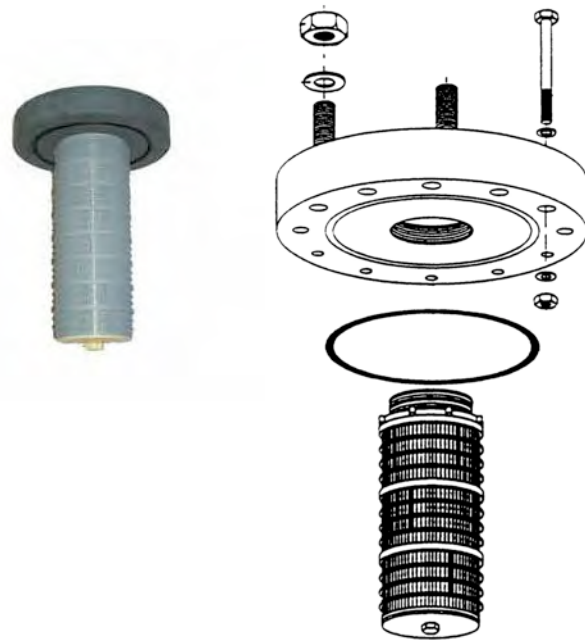

REF.	VESSEL	OUTLET	CYLINDRICAL DIFFUSOR DIAMETER (mm)	CYLINDRICAL DIFFUSOR LENGTH (mm)	SLOTS (mm)	FLOW (m ³ /h) Δp 0,2 bar	
PV512	18" ÷ 36"	DN65	85	284	0,2	20	
PV514	24" ÷ 36"	DN80	120	240	0,2	30	
PV515	42" ÷ 48"	DN80	120	312	0,2	36	
PV553	63"	DN80	120	384	0,2	50	
PV518	63"	DN100	120	384	0,2	60	
PV513	18" ÷ 36"	DN65	85	284	0,5	20	
PV516	24" ÷ 36"	DN80	120	240	0,5	30	
PV517	42" ÷ 48"	DN80	120	312	0,5	36	
PV554	63"	DN80	120	384	0,5	50	
PV519	63"	DN100	120	384	0,5	60	



Cylindrical diffusers

- PP cylindrical diffuser with thread connection 2", 3" or 4";
- slots 0,2 or 0,5 mm.

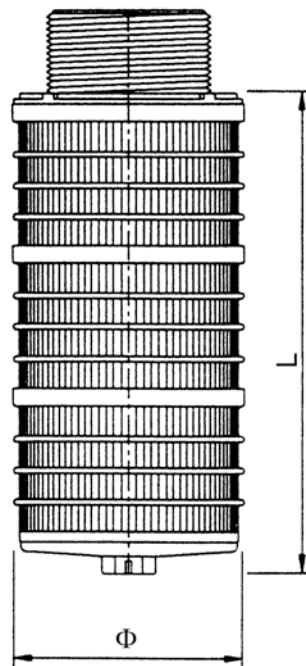

REF.	CONNECTION	DIAMETER (mm)	LENGTH (mm)	SLOTS (mm)	
PV340	2"	85	180	0,2	
PV339	2"	85	284	0,2	
PV341	2"	85	338	0,2	
PV342	2"	85	180	0,5	
PV343	2"	85	284	0,5	
PV344	2"	85	338	0,5	
PV364	3"	120	240	0,2	
PV365	3"	120	312	0,2	
PV366	3"	120	384	0,2	
PV367	3"	120	240	0,5	
PV368	3"	120	312	0,5	
PV369	3"	120	384	0,5	
PV393	4"	120	384	0,2	
PV394	4"	120	384	0,5	



Lower lateral system

- lower lateral system for vessels with 4" – 8UN opening;
- outlet connection to glue D63;
- slots 0,2 or 0,5 mm;
- materials: adapter PVC, hub and laterals PP;
- including:
 - A. union D63 (REF. PV329);
 - B. adapter 4" with O-rings (REF. PV332);
 - C. reduction 2" M/F (REF. PV335);
 - D. n.3 spacers (REF. PV337);
 - E. hub (REF. PV336);
 - F. N.5 laterals diameter 54 mm, length = see table.

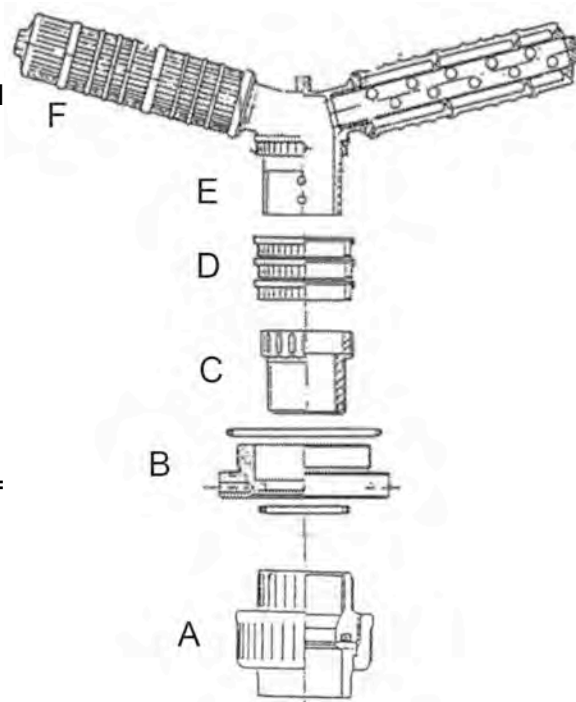

REF.	VESSEL	LATERALS LENGTH (mm)	SLOTS (mm)	FLOW (m ³ /h) Δp 0,2 bar	
PV353	14" - 16" - 18"	113	0,2	16	
PV354	21" - 24"	175	0,2	17	
PV355	30"	237	0,2	18	
PV356	36"	299	0,2	20	
PV360	14" - 16" - 18"	113	0,5	16	
PV361	21" - 24"	175	0,5	17	
PV362	30"	237	0,5	18	
PV363	36"	299	0,5	20	



Lower lateral systems with 6 laterals hub for flanged pressure vessels

- lower lateral system for 6" flanged pressure vessels;
- flange material PVC;
- complete with AISI 304 bolts and washer;
- hub at 6 laterals;
- laterals in PP, slots 0,2 or 0,5 mm, length as table below.

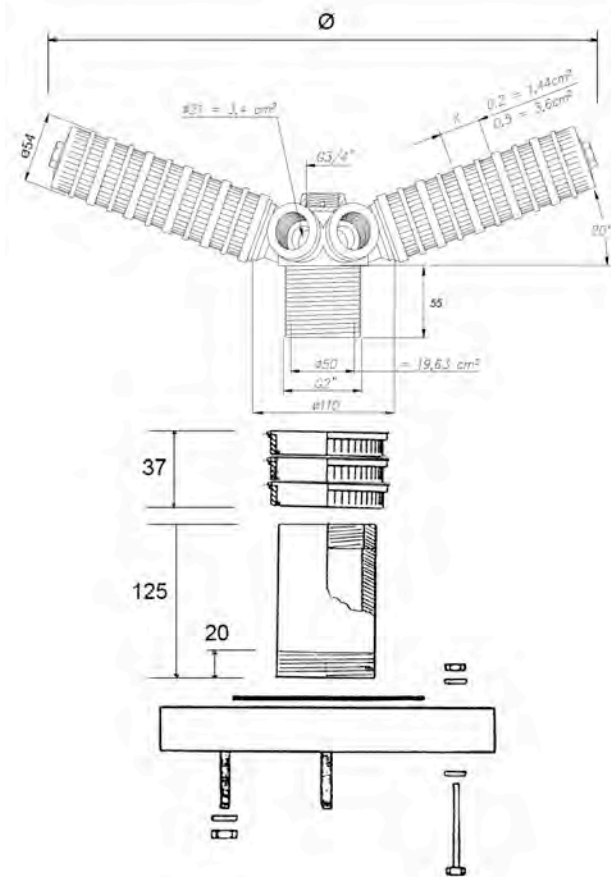

REF.	VESSEL	CONNECTION	LATERALS LENGTH (mm)	DIAMETER Ø (mm)	SLOTS (mm)	FLOW (m ³ /h) Δp 0,2 bar	
PV520	18" - 21"	DN 65	144	374	0,2	16	
PV521	24"	DN 65	175	432	0,2	17	
PV522	30"	DN 65	237	549	0,2	18	
PV523	36"	DN 65	299	665	0,2	20	
PV524	18" - 21"	DN 65	144	374	0,5	16	
PV525	24"	DN 65	175	432	0,5	17	
PV526	30"	DN 65	237	549	0,5	18	
PV527	36"	DN 65	299	665	0,5	20	



Lower lateral systems with 8 laterals hub for flanged pressure vessels

- lower lateral system for 6" flanged pressure vessels;
- flange material PVC;
- complete with AISI 304 bolts and washer;
- hub at 8 laterals;
- laterals in PP, slots 0,2 or 0,5 mm, length as table below.

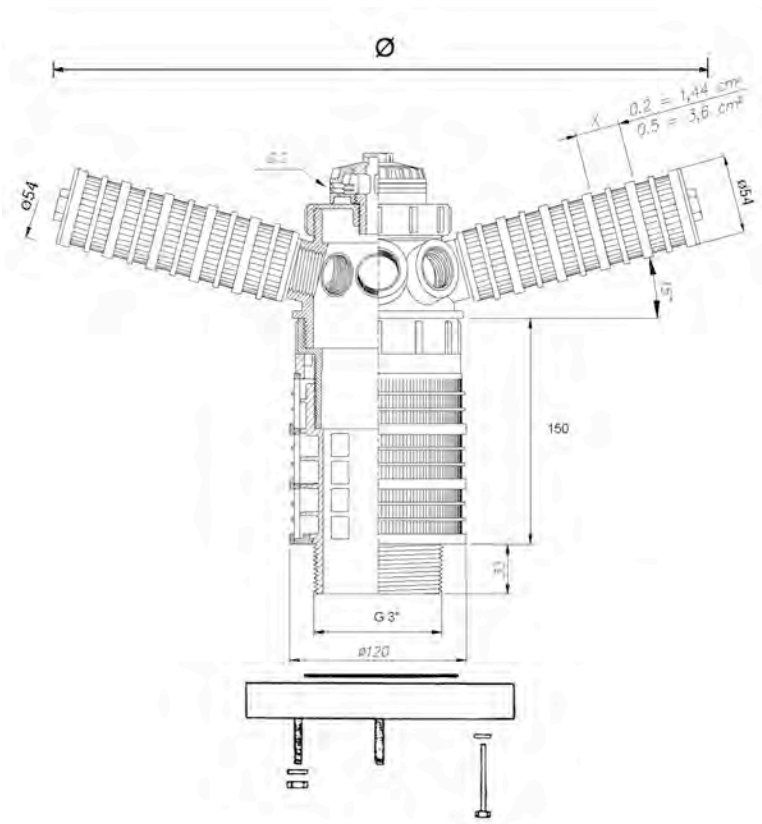

REF.	VESSEL	CONNECTION	LATERALS LENGTH (mm)	DIAMETER Ø (mm)	SLOTS (mm)	FLOW (m ³ /h) Δp 0,2 bar	
PV522A	30"	DN 65	237	580	0,2	28	
PV523A	36"	DN 65	299	699	0,2	30	
PV528	24"	DN 80	175	461	0,2	26	
PV529	30"	DN 80	237	580	0,2	28	
PV530	36"	DN 80	299	699	0,2	30	
PV526A	30"	DN 65	237	580	0,5	28	
PV527A	36"	DN 65	299	699	0,5	30	
PV531	24"	DN 80	175	461	0,5	26	
PV532	30"	DN 80	237	580	0,5	28	
PV533	36"	DN 80	299	699	0,5	30	



Lower double lateral systems for flanged pressure vessels

- lower double lateral system for 6" flanged pressure vessels;
- flange material PVC, bolts in AISI 304;
- complete with bolts and washer;
- double hub at 8 + 8 laterals;
- laterals in PP, slots 0,2 or 0,5 mm, length as table below.

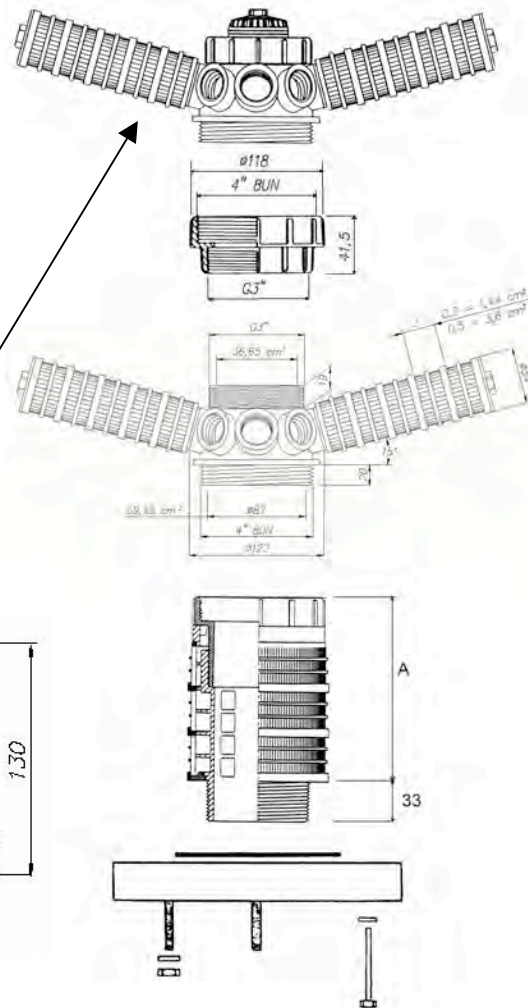
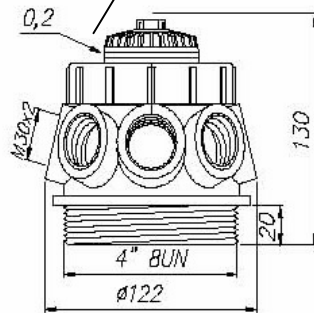

REF.	VESSEL	CONNECTION	LATERALS QUANTITY	A (mm)	LATERALS LENGTH (mm)	SYSTEMS DIAMETERS (mm)	SLOTS (mm)	FLOW (m3/h) Δp 0,2 bar
PV534	42"	DN 80	8 + 8	150	361 423	819 939	0,2	32
PV535	48"	DN 80	8 + 8	150	423 485	939 1059	0,2	36
PV555	63"	DN 80	8 + 8	190	578 640	1239 1359	0,2	50
PV538	63"	DN 100	8 + 8	190	578 640	1239 1359	0,2	60
PV536	42"	DN 80	8 + 8	150	361 423	819 939	0,5	32
PV537	48"	DN 80	8 + 8	150	423 485	939 1059	0,5	36
PV556	63"	DN 80	8 + 8	190	578 640	1239 1359	0,5	50
PV539	63"	DN 100	8 + 8	190	578 640	1239 1359	0,5	60



Top mount lower lateral systems for flanged pressure vessels

- lower lateral system for 6" flanged pressure vessels for top mount valve, with 6 laterals;
- material hub and laterals PP, length as table below;
- slots 0,2 or 0,5 mm;
- to install with 2" adapter for the needed riser tube diameter.

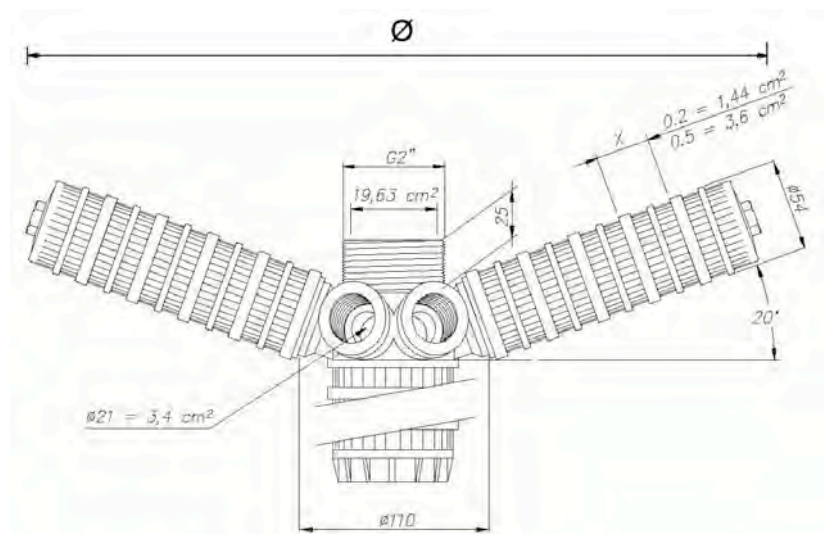

REF.	VESSEL	LATERALS LENGTH (mm)	DIAMETER Ø (mm)	SLOTS (mm)	FLOW (m ³ /h) Δp 0,2 bar
PV540	18" - 21"	144	374	0,2	16
PV541	24"	175	432	0,2	17
PV542	30"	237	549	0,2	18
PV543	36"	299	665	0,2	20
PV544	18" - 21"	144	374	0,5	16
PV545	24"	175	432	0,5	17
PV546	30"	237	549	0,5	18
PV547	36"	299	665	0,5	20

2" gas adapter

- 2" GAS adapters with connection to glue;
- material PVC.

REF.	CONNECTION TO GLUE (mm)
PV384	41,8
PV385	48,3
PV386	50,0
PV387	63,0

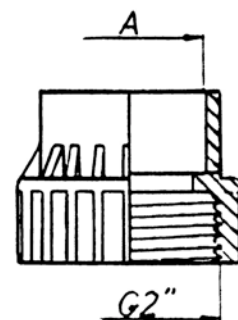

Pressure Vessels Accessories



Top mount lower lateral systems for tubes diameter 90 mm

- lower lateral system for 6" flanged pressure vessels for top mount valve, with 8 laterals;
- material hub and laterals PP, length as table below;
- slots 0,2;
- to glue on tube diameter 90 mm.

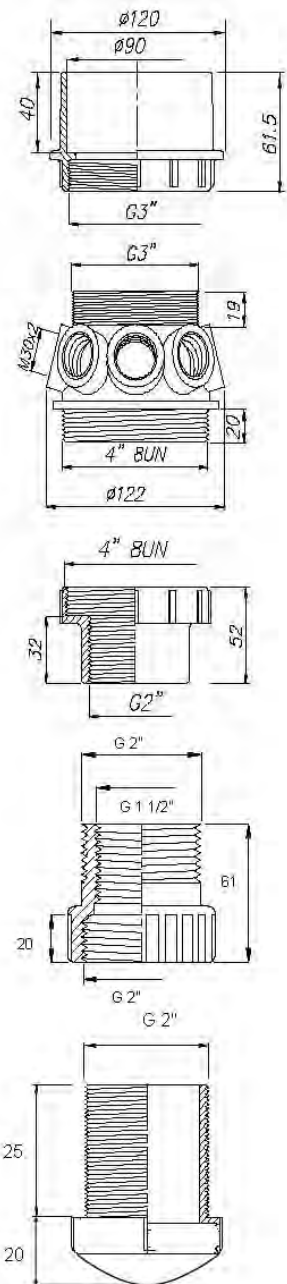
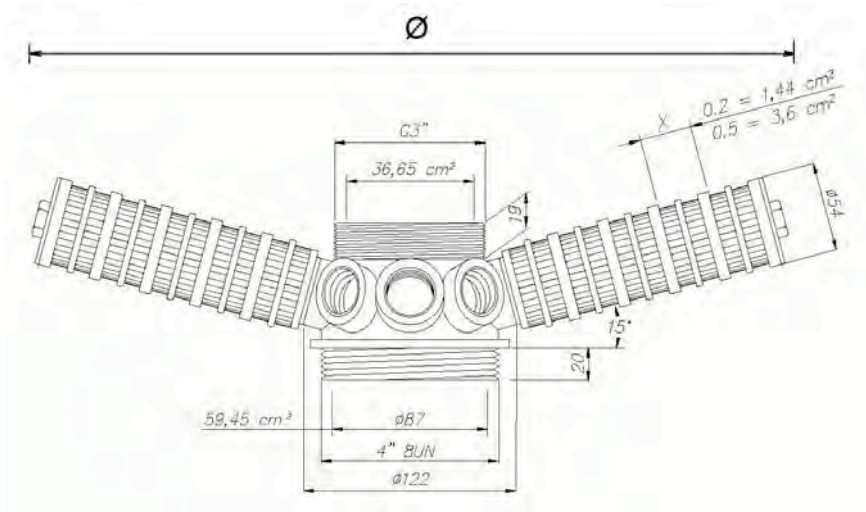

REF.	PRESSURE VESSEL	LATERALS LENGTH (mm)	DIAMETER \emptyset (mm)	SLOTS (mm)	FLOW (m ³ /h) Δp 0,2 bar
PV548	30"	237	580	0,2	28
PV549	36"	299	699	0,2	30



Top mount lower double lateral systems for tubes diameter 90 mm

- lower lateral system for 6" flanged pressure vessels for top mount valve, with 8+8 laterals;
- material hub and laterals PP, length as table below;
- slots 0,2;
- to glue on tube diameter 90 mm.

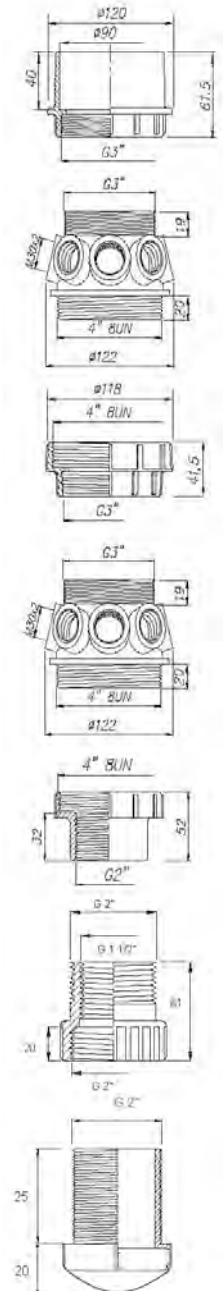
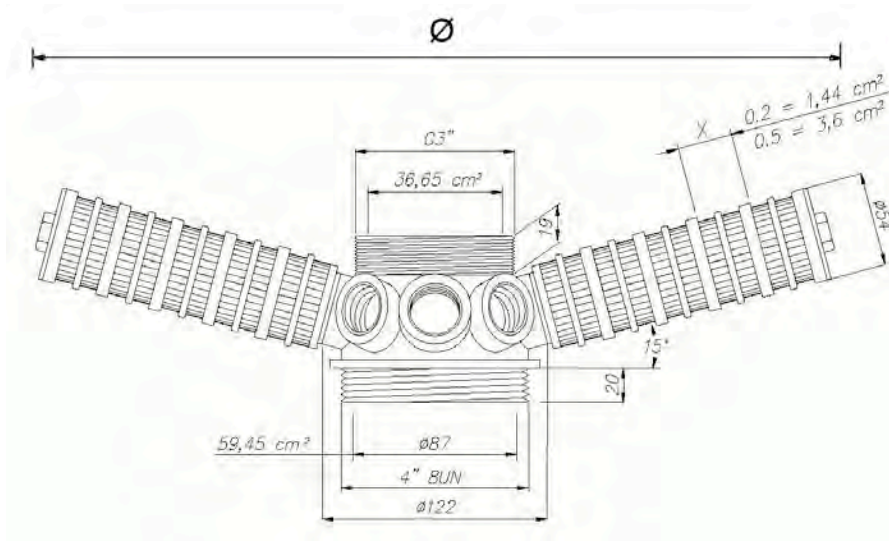

REF.	PRESSURE VESSEL	LATERALS QUANTITY	LATERALS LENGTH (mm)	DIAMETERS Ø (mm)	SLOTS (mm)	FLOW (m3/h) Δp 0,2 bar	
PV550	42"	8 + 8	299 423	699 939	0,2	31	
PV551	48"	8 + 8	361 485	819 1059	0,2	34	



Cylindrical laterals

- cylindrical laterals with threaded connection
- M 30x2;
- material PP;
- diameter 54 mm;
- slots 0,2 or 0,5 mm.

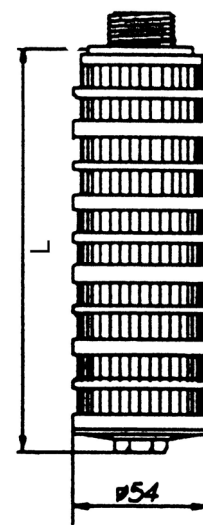

Laterals with 0,2 mm slots											
REF.	PV345	PV370	PV346	PV371	PV347	PV348	PV372	PV373	PV374	PV389	PV391
LENGTH (mm)	113	144	175	206	237	299	361	423	485	578	640

Laterals with 0,5 mm slots											
REF.	PV375	PV376	PV377	PV378	PV379	PV380	PV381	PV382	PV383	PV390	PV392
LENGTH (mm)	113	144	175	206	237	299	361	423	485	578	640

Flange coupling kit

- for 6" flanged pressure vessels;
- including flange adaptor and coupling flange in PVC;
- with o-ring in EPDM.

REF.	CONNECTION	
PV594	DN65	
PV595	DN80	
PV596	DN100	





Mineral tank funnels

- The tank funnels are designed for filling mineral tanks with granular media and ion exchange resin;
- the funnels are designed to fit 2,5", 4" and 6" mineral tank openings;
- these economical funnels are nestable to reduce shipping and storage costs;
- the funnel ref. PV395 snaps into a 4" or 6" mineral tank opening for stability when pouring media. The neck of the funnel has been carefully designed to allow trapped air inside the mineral tank to escape when media is poured in. This heavy duty part is blow molded out of high density polyethylene for exceptional strength and durability. The oval design provides an extra wide opening for ease of use when pouring. Handles are molded into the funnel for added convenience.



REF.	DESCRIPTION	
PV295	Funnel 2,5" openings	
PV395	Funnel 4" and 6" openings	

WELLMATE Pressure Vessels



- Pressure Vessels, suitable for industrial and potable water treatment systems;
- Made in U.S.A.;
- In Polyether Urethane (PEU);
- CE and NSF/ANSI 61 certified;
- European 97/23/EC Directive compliant for pressure equipment (PED);
- Max operating external temperature 50 °C;
- Max operating internal temperature 38 °C;
- Min. operating temperature 4 °C;
- Grey colour;
- Warranty 5 years.

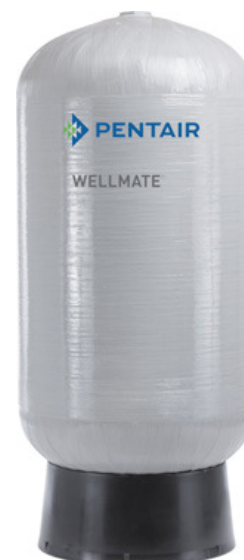

REF.	VOLUME (liters)	MAX OPERATING PRESSURE (bar)	DIAMETER (mm)	TOTAL HEIGHT (mm)	IN-OUT HEIGHT FROM THE FLOOR (mm)	CONNECTION (inch)	WEIGHT (kg)
BWM0060	55	8,5	410	660	44	1" NPT M	7
BWM0075	75	8,5	410	810	44	1" NPT M	8
BWM0120	112	8,5	410	1120	44	1" NPT M	11
BWM0150	153	8,5	530	1570	57	1" NPT M	30
BWM0180	178	8,5	610	1050	57	1 1/4" NPT M	23
BWM0235	235	8,5	610	1400	57	1 1/4" NPT M	33
BWM0330	328	8,5	610	1400	57	1 1/4" NPT M	33
BWM0450	453	8,5	610	1890	57	1 1/4" NPT M	43
BWM-LP-075	73	8,5	610	510	57	1" NPT M	11
BWM-LP-130	131	8,5	610	710	57	1" NPT M	14
BWM0600	606	10,0	760	1740	150	2" NPT M	76
BWM-IN-0750	757	10,0	760	2060	150	2" NPT M	89
BWM-IN-1000	1022	10,0	920	2120	200	2" NPT M	117
BWM-HP-110	114	5,0	410	1110	38	1 1/4" NPT M	12
BWM-HP-150	151	5,0	410	1440	38	1 1/4" NPT M	13
BWM-HP-300	303	5,0	530	1570	51	1 1/4" NPT M	16
BWM-HP-450	454	5,0	610	1840	51	1 1/4" NPT M	29

Note: Diameter, height and weight could change without prior advice.



Accessories and Spare Parts:

REF.	DESCRIPTION	
BWM-AC-0600	AIRCELL REPLACEMENT KIT FOR BWM0600	
BWM-AC-0750	AIRCELL REPLACEMENT KIT FOR BWM-IN-0750	
BWM-AC-1000	AIRCELL REPLACEMENT KIT FOR BWM-IN-1000	
BWM-AVC-20290	AIR VOLUME CONTROL ASSEMBLY FOR BWM-HP-110	
BWM-AVC-20288	AIR VOLUME CONTROL ASSEMBLY FOR BWM-HP-150	
BWM-AVC-20287	AIR VOLUME CONTROL ASSEMBLY FOR BWM-HP-300	
BWM-AVC-20291	AIR VOLUME CONTROL ASSEMBLY FOR BWM-HP-450	
BWM-AVC-1	AIR VOLUME CONTROL ASSEMBLY FOR BWM-HP/UT	
BWM-BA-20513	WELLMATE BASE 180/300	
BWM-DA-3174	WM SCREEN & ADAPT. ASSY + O-RING - 4" X 2" NPSM	
BWM-DA-HU79	WM BOTTOM DRAIN + 1 1/4" NPT THREADED PIPES HP110-150	
BWM-DA-HU86	WM BOTTOM DRAIN + 1 1/4" NPT THREADED PIPES HP300-450	
BWM-PB-001	WM PUMP MOUNT BRACKET	
BWM-AI-01	WM AIR INJECTOR/MICRONIZER-HP	
BWM-VB-10724	WM VACUUM BREAKER UT/HP	
BWM-CL-0002	WM "H" CLIP	



Cabinets



Cabinets for Softeners Mini Cab Series



- cabinets for residential softeners, complete with salt lid and cover of exclusive design;
- materials: tank in HDPE, cover in polystyrene;
- standard colours:
- white tank and blue or black cover;
- on demand and for quantities we can realize customized colours;
- EU design patent no. 003156272.



REF. WITH WHITE TANK AND BLUE COVER	C0613MWMAS	C0713MWMAS
REF. WITH WHITE TANK AND BLACK COVER	C0613MWMDS	C0713MWMDS
MODEL	MINI CAB 13	MINI CAB 13
WIDTH (mm)	220	220
LENGTH (mm)	365	365
HEIGHT (mm)	333	333
WITH MWG TANK	6 x 13	7 x 13

Cabinets for Softeners New Junior Series



- cabinets for residential softeners, complete with salt lid;
- materials: tank in HDPE, salt lid in polystyrene;
- colours: tank white, salt lid black;
- different colours available on demand ;
- EU design patent no. 003156272.

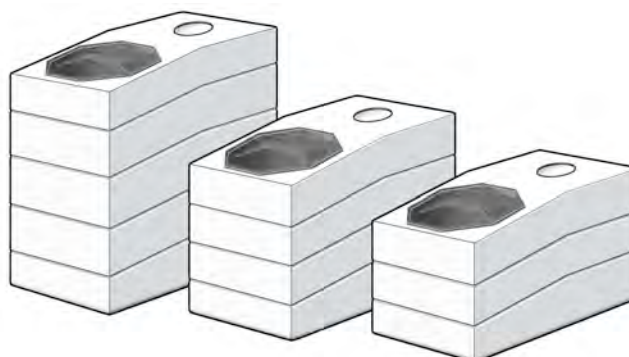

REF.	MODEL	WIDTH (mm)	LENGTH (mm)	HEIGHT (mm)	WITH MWG TANK	
C0613GWGDY	NEW JUNIOR 13	240	435	330	6 x 13	
C0713GWGDY	NEW JUNIOR 13	240	435	330	7 x 13	
C0813GWGDY	NEW JUNIOR 13	240	435	330	8 x 13	
C0717GWGDY	NEW JUNIOR 17	240	435	432	7 x 17	
C0817GWGDY	NEW JUNIOR 17	240	435	432	8 x 17	
C0724GWGDY	NEW JUNIOR 24	240	435	610	7 x 24	
C0824GWGDY	NEW JUNIOR 24	240	435	610	8 x 24	

ACCESSORIES

REF.	DESCRIPTION	DIAMETER (mm)	HEIGHT (mm)	
PA012	BRINE WELL FOR 13"	100	220	
PA003	BRINE WELL FOR 17"	100	342	
PA075	BRINE WELL FOR 24"	100	520	

Cabinets for Softeners Slim Line Series



- cabinets for residential softeners, complete with salt lid and cover of exclusive design;
- materials: tank in HDPE, cover in polystyrene;
- standard colours:
- white tank and blue cover;
- on demand and for quantities we can realize customized colours;
- EU design patent no. 003156272.



REF.	MODEL	WIDTH (mm)	LENGTH (mm)	HEIGHT (mm)	WITH MWG TANK	
C0717LWSAS	SLIM LINE 17	320	500	440	7 x 17	
C0817LWSAS	SLIM LINE 17	320	500	440	8 x 17	
C0917LWSAS	SLIM LINE 17	320	500	440	9 x 17	
C1017LWSAS	SLIM LINE 17	320	500	440	10 x 17	
C0724LWSAS	SLIM LINE 24	320	500	620	7 x 24	
C0824LWSAS	SLIM LINE 24	320	500	620	8 x 24	
C0924LWSAS	SLIM LINE 24	320	500	620	9 x 24	
C1024LWSAS	SLIM LINE 24	320	500	620	10 x 24	
C0735LWSAS	SLIM LINE 35	320	500	900	7 x 35	
C0835LWSAS	SLIM LINE 35	320	500	900	8 x 35	
C0935LWSAS	SLIM LINE 35	320	500	900	9 x 35	
C1035LWSAS	SLIM LINE 35	320	500	900	10 x 35	

ACCESSORIES

REF.	DESCRIPTION	DIAMETER (mm)	HEIGHT (mm)	
PA003	BRINE WELL FOR 17"	100	340	
PA075	BRINE WELL FOR 24"	100	520	
PA077	BRINE WELL FOR 35"	100	780	

Cabinets for Softeners Slim Surf Series



- cabinets for residential softeners, complete with salt lid and cover of exclusive design;
- materials: tank in HDPE, cover in polystyrene;
- standard colours:
- white tank and blue cover;
- on demand and for quantities we can realize customized colours;
- EU design patent no. 003156272.



REF.	MODEL	WIDTH (mm)	LENGTH (mm)	HEIGHT (mm)	WITH MWG TANK	
C0717SWSAS	SLIM SURF 17	320	500	440	7 x 17	
C0817SWSAS	SLIM SURF 17	320	500	440	8 x 17	
C0917SWSAS	SLIM SURF 17	320	500	440	9 x 17	
C1017SWSAS	SLIM SURF 17	320	500	440	10 x 17	
C0724SWSAS	SLIM SURF 24	320	500	620	7 x 24	
C0824SWSAS	SLIM SURF 24	320	500	620	8 x 24	
C0924SWSAS	SLIM SURF 24	320	500	620	9 x 24	
C1024SWSAS	SLIM SURF 24	320	500	620	10 x 24	
C0735SWSAS	SLIM SURF 35	320	500	900	7 x 35	
C0835SWSAS	SLIM SURF 35	320	500	900	8 x 35	
C0935SWSAS	SLIM SURF 35	320	500	900	9 x 35	
C1035SWSAS	SLIM SURF 35	320	500	900	10 x 35	

ACCESSORIES				
REF.	DESCRIPTION	DIAMETER (mm)	HEIGHT (mm)	
PA003	BRINE WELL FOR 17"	100	340	
PA075	BRINE WELL FOR 24"	100	520	
PA077	BRINE WELL FOR 35"	100	780	

Cabinets for Softeners Top Line Series



- cabinets for residential softeners, complete with salt lid and cover of exclusive design;
- materials: tank in HDPE, cover in polystyrene;
- standard colours:
- white tank and blue cover;
- on demand and for quantities we can realize customized colours;
- EU design patent no. 003156272.



REF.	MODEL	WIDTH (mm)	LENGTH (mm)	HEIGHT (mm)	WITH MWG TANK	
C0717LWTAS	TOP LINE 17	320	500	670	7 x 17	
C0817LWTAS	TOP LINE 17	320	500	670	8 x 17	
C0917LWTAS	TOP LINE 17	320	500	670	9 x 17	
C1017LWTAS	TOP LINE 17	320	500	670	10 x 17	
C0724LWTAS	TOP LINE 24	320	500	840	7 x 24	
C0824LWTAS	TOP LINE 24	320	500	840	8 x 24	
C0924LWTAS	TOP LINE 24	320	500	840	9 x 24	
C1024LWTAS	TOP LINE 24	320	500	840	10 x 24	
C0735LWTAS	TOP LINE 35	320	500	1140	7 x 35	
C0835LWTAS	TOP LINE 35	320	500	1140	8 x 35	
C0935LWTAS	TOP LINE 35	320	500	1140	9 x 35	
C1035LWTAS	TOP LINE 35	320	500	1140	10 x 35	

ACCESSORIES				
REF.	DESCRIPTION	DIAMETER (mm)	HEIGHT (mm)	
PA003	BRINE WELL FOR 17"	100	340	
PA075	BRINE WELL FOR 24"	100	520	
PA077	BRINE WELL FOR 35"	100	780	

Cabinets for Softeners Top Surf Series



- cabinets for residential softeners, complete with salt lid and cover of exclusive design;
- materials: tank in HDPE, cover in polystyrene;
- standard colours:
- white tank and blue cover;
- on demand and for quantities we can realize customized colours;
- EU design patent no. 003156272.



REF.	MODEL	WIDTH (mm)	LENGTH (mm)	HEIGHT (mm)	WITH MWG TANK	
C0717SWTAS	TOP SURF 17	320	500	670	7 x 17	
C0817SWTAS	TOP SURF 17	320	500	670	8 x 17	
C0917SWTAS	TOP SURF 17	320	500	670	9 x 17	
C1017SWTAS	TOP SURF 17	320	500	670	10 x 17	
C0724SWTAS	TOP SURF 24	320	500	840	7 x 24	
C0824SWTAS	TOP SURF 24	320	500	840	8 x 24	
C0924SWTAS	TOP SURF 24	320	500	840	9 x 24	
C1024SWTAS	TOP SURF 24	320	500	840	10 x 24	
C0735SWTAS	TOP SURF 35	320	500	1140	7 x 35	
C0835SWTAS	TOP SURF 35	320	500	1140	8 x 35	
C0935SWTAS	TOP SURF 35	320	500	1140	9 x 35	
C1035SWTAS	TOP SURF 35	320	500	1140	10 x 35	

ACCESSORIES				
REF.	DESCRIPTION	DIAMETER (mm)	HEIGHT (mm)	
PA003	BRINE WELL FOR 17"	100	340	
PA075	BRINE WELL FOR 24"	100	520	
PA077	BRINE WELL FOR 35"	100	780	

Cabinets for Softeners Top Line Clear Series



- cabinets for residential softeners, complete with salt lid and cover of exclusive design with transparent insert;
- materials: tank in HDPE, cover in polystyrene;
- standard colours:
- white tank and blue cover;
- on demand and for quantities we can realize customized colours;
- EU design patent no. 003156272.



REF.	MODEL	WIDTH (mm)	LENGTH (mm)	HEIGHT (mm)	WITH MWG TANK	
C0717LWTPS	TOP LINE CLEAR 17	320	500	670	7 x 17	
C0817LWTPS	TOP LINE CLEAR 17	320	500	670	8 x 17	
C0917LWTPS	TOP LINE CLEAR 17	320	500	670	9 x 17	
C1017LWTPS	TOP LINE CLEAR 17	320	500	670	10 x 17	
C0724LWTPS	TOP LINE CLEAR 24	320	500	840	7 x 24	
C0824LWTPS	TOP LINE CLEAR 24	320	500	840	8 x 24	
C0924LWTPS	TOP LINE CLEAR 24	320	500	840	9 x 24	
C1024LWTPS	TOP LINE CLEAR 24	320	500	840	10 x 24	
C0735LWTPS	TOP LINE CLEAR 35	320	500	1140	7 x 35	
C0835LWTPS	TOP LINE CLEAR 35	320	500	1140	8 x 35	
C0935LWTPS	TOP LINE CLEAR 35	320	500	1140	9 x 35	
C1035LWTPS	TOP LINE CLEAR 35	320	500	1140	10 x 35	

ACCESSORIES

REF.	DESCRIPTION	DIAMETER (mm)	HEIGHT (mm)	
PA003	BRINE WELL FOR 17"	100	340	
PA075	BRINE WELL FOR 24"	100	520	
PA077	BRINE WELL FOR 35"	100	780	

Cabinets for Softeners Top Surf Clear Series



- cabinets for residential softeners, complete with salt lid and cover of exclusive design with transparent insert;
- materials: tank in HDPE, cover in polystyrene;
- standard colours:
- white tank and blue cover;
- on demand and for quantities we can realize customized colours;
- EU design patent no. 003156272.



REF.	MODEL	WIDTH (mm)	LENGTH (mm)	HEIGHT (mm)	WITH MWG TANK	
C0717SWTPS	TOP SURF CLEAR 17	320	500	670	7 x 17	
C0817SWTPS	TOP SURF CLEAR 17	320	500	670	8 x 17	
C0917SWTPS	TOP SURF CLEAR 17	320	500	670	9 x 17	
C1017SWTPS	TOP SURF CLEAR 17	320	500	670	10 x 17	
C0724SWTPS	TOP SURF CLEAR 24	320	500	840	7 x 24	
C0824SWTPS	TOP SURF CLEAR 24	320	500	840	8 x 24	
C0924SWTPS	TOP SURF CLEAR 24	320	500	840	9 x 24	
C1024SWTPS	TOP SURF CLEAR 24	320	500	840	10 x 24	
C0735SWTPS	TOP SURF CLEAR 35	320	500	1140	7 x 35	
C0835SWTPS	TOP SURF CLEAR 35	320	500	1140	8 x 35	
C0935SWTPS	TOP SURF CLEAR 35	320	500	1140	9 x 35	
C1035SWTPS	TOP SURF CLEAR 35	320	500	1140	10 x 35	

ACCESSORIES

REF.	DESCRIPTION	DIAMETER (mm)	HEIGHT (mm)	
PA003	BRINE WELL FOR 17"	100	340	
PA075	BRINE WELL FOR 24"	100	520	
PA077	BRINE WELL FOR 35"	100	780	

Cabinets for Softeners New Crystal



- cabinets for residential softeners, complete with salt lid and cover of exclusive design with clear insert;
- materials: tank and salt lid in HDPE, cover in polystyrene;
- standard colours:
- white tank and blue cover;
- other colours available:
- tank grey;
- cover white or black;
- on demand and for quantities we can realize customized colours;
- EU design patent no. 003156272.

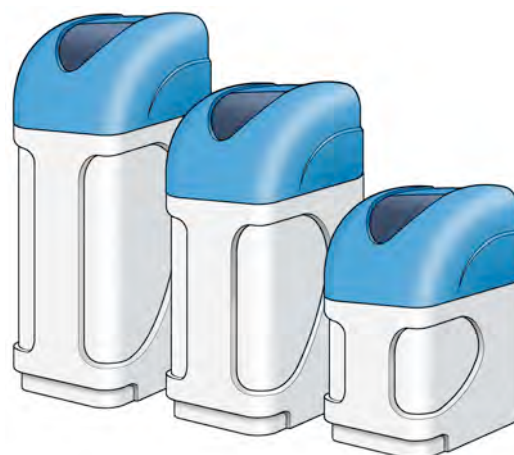

REF.	MODEL	WIDTH (mm)	LENGTH (mm)	HEIGHT (mm)	WITH MWG TANK	
C0717NWCAS	NEWMINI CRYSTAL	320	500	670	7 x 17	
C0817NWCAS	NEWMINI CRYSTAL	320	500	670	8 x 17	
C0917NWCAS	NEWMINI CRYSTAL	320	500	670	9 x 17	
C1017NWCAS	NEWMINI CRYSTAL	320	500	670	10 x 17	
C0730NWCAS	NEWMIDI CRYSTAL	320	500	1010	7 x 30	
C0830NWCAS	NEWMIDI CRYSTAL	320	500	1010	8 x 30	
C0930NWCAS	NEWMIDI CRYSTAL	320	500	1010	9 x 30	
C1030NWCAS	NEWMIDI CRYSTAL	320	500	1010	10 x 30	
C0735NWCAS	NEWMAXI CRYSTAL	320	500	1140	7 x 35	
C0835NWCAS	NEWMAXI CRYSTAL	320	500	1140	8 x 35	
C0935NWCAS	NEWMAXI CRYSTAL	320	500	1140	9 x 35	
C1035NWCAS	NEWMAXI CRYSTAL	320	500	1140	10 x 35	

ACCESSORIES

REF.	DESCRIPTION	DIAMETER (mm)	HEIGHT (mm)	
PA003	BRINE WELL FOR NEWMINI	100	342	
PA010	BRINE WELL FOR NEWMIDI	100	690	
PA005	BRINE WELL FOR NEWMAXI	100	820	

Cabinets for Softeners New Iceberg



- cabinets for residential softeners, complete with salt lid and cover of exclusive design;
- materials: tank and salt lid in HDPE, cover in polystyrene;
- standard colours:
- tank white and blue cover with white insert;
- on demand and for quantities we can realize customized colours;
- EU design patent no. 003156272.



REF.	MODEL	WIDTH (mm)	LENGTH (mm)	HEIGHT (mm)	WITH MWG TANK	
C0717NWIQS	NEWMINI ICEBERG	320	500	670	7 x 17	
C0817NWIQS	NEWMINI ICEBERG	320	500	670	8 x 17	
C0917NWIQS	NEWMINI ICEBERG	320	500	670	9 x 17	
C1017NWIQS	NEWMINI ICEBERG	320	500	670	10 x 17	
C0730NWIQS	NEWMIDI ICEBERG	320	500	1010	7 x 30	
C0830NWIQS	NEWMIDI ICEBERG	320	500	1010	8 x 30	
C0930NWIQS	NEWMIDI ICEBERG	320	500	1010	9 x 30	
C1030NWIQS	NEWMIDI ICEBERG	320	500	1010	10 x 30	
C0735NWIQS	NEWMAXI ICEBERG	320	500	1140	7 x 35	
C0835NWIQS	NEWMAXI ICEBERG	320	500	1140	8 x 35	
C0935NWIQS	NEWMAXI ICEBERG	320	500	1140	9 x 35	
C1035NWIQS	NEWMAXI ICEBERG	320	500	1140	10 x 35	

ACCESSORIES				
REF.	DESCRIPTION	DIAMETER (mm)	HEIGHT (mm)	
PA003	BRINE WELL FOR NEWMINI	100	342	
PA010	BRINE WELL FOR NEWMIDI	100	690	
PA005	BRINE WELL FOR NEWMAXI	100	820	

Cabinet for Softeners Ocean Series



- cabinets for residential softeners complete with new design cover with clear insert;
- materials: tank in HDPE, cover in polystyrene;
- standard colours:
- white tank and blue cover;
- other colours available:
- tank grey;
- cover white or black;
- on demand and for quantities we can realize customized colours;
- EU design patent no. 003156272.



REF.	MODEL	WIDTH (mm)	LENGTH (mm)	HEIGHT (mm)	WITH MWG TANK	
C0717NWOAS	NEWMINI OCEAN	320	500	670	7 x 17	
C0817NWOAS	NEWMINI OCEAN	320	500	670	8 x 17	
C0917NWOAS	NEWMINI OCEAN	320	500	670	9 x 17	
C1017NWOAS	NEWMINI OCEAN	320	500	670	10 x 17	
C0730NWOAS	NEWMIDI OCEAN	320	500	1010	7 x 30	
C0830NWOAS	NEWMIDI OCEAN	320	500	1010	8 x 30	
C0930NWOAS	NEWMIDI OCEAN	320	500	1010	9 x 30	
C1030NWOAS	NEWMIDI OCEAN	320	500	1010	10 x 30	
C0735NWOAS	NEWMAXI OCEAN	320	500	1140	7 x 35	
C0835NWOAS	NEWMAXI OCEAN	320	500	1140	8 x 35	
C0935NWOAS	NEWMAXI OCEAN	320	500	1140	9 x 35	
C1035NWOAS	NEWMAXI OCEAN	320	500	1140	10 x 35	

ACCESSORIES				
REF.	DESCRIPTION	DIAMETER (mm)	HEIGHT (mm)	
PA003	BRINE WELL FOR NEWMINI	100	342	
PA010	BRINE WELL FOR NEWMIDI	100	690	
PA005	BRINE WELL FOR NEWMAXI	100	820	

Cabinets for Softeners Logix Series



- cabinets for residential softeners complete with special cover for integrate installation of LOGIX control Autotrol valves;
- materials: tank in HDPE, cover in polystyrene;
- standard colours:
- white tank and blue cover;
- other colours available:
- tank grey;
- cover white or black;
- on demand and for quantities we can realize customized colours;
- EU design patent no. 003156272.



REF.	MODEL	WIDTH (mm)	LENGTH (mm)	HEIGHT (mm)	WITH MWG TANK	
C0717NWLAS	NEWMINI LOGIX	320	500	670	7 x 17	
C0817NWLAS	NEWMINI LOGIX	320	500	670	8 x 17	
C0917NWLAS	NEWMINI LOGIX	320	500	670	9 x 17	
C1017NWLAS	NEWMINI LOGIX	320	500	670	10 x 17	
C0730NWLAS	NEWMIDI LOGIX	320	500	1010	7 x 30	
C0830NWLAS	NEWMIDI LOGIX	320	500	1010	8 x 30	
C0930NWLAS	NEWMIDI LOGIX	320	500	1010	9 x 30	
C1030NWLAS	NEWMIDI LOGIX	320	500	1010	10 x 30	
C0735NWLAS	NEWMAXI LOGIX	320	500	1140	7 x 35	
C0835NWLAS	NEWMAXI LOGIX	320	500	1140	8 x 35	
C0935NWLAS	NEWMAXI LOGIX	320	500	1140	9 x 35	
C1035NWLAS	NEWMAXI LOGIX	320	500	1140	10 x 35	

ACCESSORIES

REF.	DESCRIPTION	DIAMETER (mm)	HEIGHT (mm)	
PA003	BRINE WELL FOR NEWMINI	100	342	
PA010	BRINE WELL FOR NEWMIDI	100	690	
PA005	BRINE WELL FOR NEWMAXI	100	820	

Cabinets for Softeners Crystal Series



- cabinets for residential softeners, complete with salt lid and cover of exclusive design with clear insert;
- materials: tank and salt lid in HDPE, cover in polystyrene;
- standard colours:
- white tank and blue cover;
- other colours available:
- tank grey;
- cover white or black;
- on demand and for quantities we can realize customized colours;
- EU design patent no. 003156272.

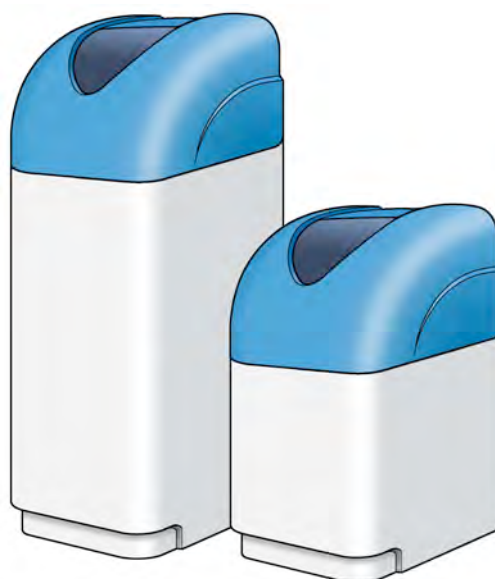

REF.	MODEL	WIDTH (mm)	LENGTH (mm)	HEIGHT (mm)	WITH MWG TANK	
C0717EWCAS	MINI CRYSTAL	320	500	670	7 x 17	
C0817EWCAS	MINI CRYSTAL	320	500	670	8 x 17	
C0917EWCAS	MINI CRYSTAL	320	500	670	9 x 17	
C1017EWCAS	MINI CRYSTAL	320	500	670	10 x 17	
C0735EWCAS	MAXI CRYSTAL	320	500	1140	7 x 35	
C0835EWCAS	MAXI CRYSTAL	320	500	1140	8 x 35	
C0935EWCAS	MAXI CRYSTAL	320	500	1140	9 x 35	
C1035EWCAS	MAXI CRYSTAL	320	500	1140	10 x 35	

ACCESSORIES				
REF.	DESCRIPTION	DIAMETER (mm)	HEIGHT (mm)	
PA003	BRINE WELL FOR MINI	100	342	
PA005	BRINE WELL FOR MAXI	100	820	

Cabinets for Softeners Iceberg Series



- cabinets for residential softeners, complete with salt lid and cover of exclusive design;
- materials: tank and salt lid in HDPE, cover in polystyrene;
- standard colours:
- tank and salt lid white;
- blue cover with white insert;
- on demand and for quantities we can realize customized colours;
- EU design patent no. 003156272.



REF.	MODEL	WIDTH (mm)	LENGTH (mm)	HEIGHT (mm)	WITH MWG TANK	
C0717EWIQS	MINI ICEBERG	320	500	670	7 x 17	
C0817EWIQS	MINI ICEBERG	320	500	670	8 x 17	
C0917EWIQS	MINI ICEBERG	320	500	670	9 x 17	
C1017EWIQS	MINI ICEBERG	320	500	670	10 x 17	
C0735EWIQS	MAXI ICEBERG	320	500	1140	7 x 35	
C0835EWIQS	MAXI ICEBERG	320	500	1140	8 x 35	
C0935EWIQS	MAXI ICEBERG	320	500	1140	9 x 35	
C1035EWIQS	MAXI ICEBERG	320	500	1140	10 x 35	

ACCESSORIES

REF.	DESCRIPTION	DIAMETER (mm)	HEIGHT (mm)	
PA003	BRINE WELL FOR MINI	100	342	
PA005	BRINE WELL FOR MAXI	100	820	

Cabinets for Softeners Joker Series



- JOKER brine/resin tanks that can be combined in special bi-blocs cabinets;
- capacity as brine tank 82 liters;
- suitable to fit 7" - 8" - 9" - 10" x 35" tanks as resin tank;
- overall dimensions 310 x 310 mm height 900 mm;
- materials: tank in HDPE, cover in ABS;
- standard colours as per table; special colours available on request;
- EU design patent no. 003156272.

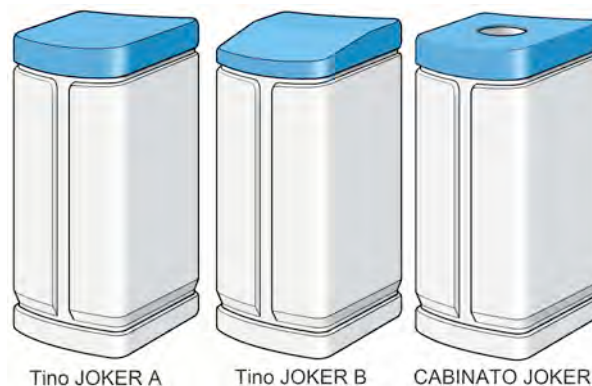

JOKER RESIN TANKS				
REF.	MODEL	COLOURS	WITH MWG TANK	
C0735AWJDX	JOKER 7 x 35	WHITE WITH BLACK COVER	7 x 35	
C0835AWJDX	JOKER 8 x 35	WHITE WITH BLACK COVER	8 x 35	
C0935AWJDX	JOKER 9 x 35	WHITE WITH BLACK COVER	9 x 35	
C1035AWJDX	JOKER 10 x 35	WHITE WITH BLACK COVER	10 x 35	
C0735AWJAX	JOKER 7 x 35	WHITE WITH BLUE COVER	7 x 35	
C0835AWJAX	JOKER 8 x 35	WHITE WITH BLUE COVER	8 x 35	
C0935AWJAX	JOKER 9 x 35	WHITE WITH BLUE COVER	9 x 35	
C1035AWJAX	JOKER 10 x 35	WHITE WITH BLUE COVER	10 x 35	
C0735AWJWX	JOKER 7 x 35	WHITE WITH WHITE COVER	7 x 35	
C0835AWJWX	JOKER 8 x 35	WHITE WITH WHITE COVER	8 x 35	
C0935AWJWX	JOKER 9 x 35	WHITE WITH WHITE COVER	9 x 35	
C1035AWJWX	JOKER 10 x 35	WHITE WITH WHITE COVER	10 x 35	

JOKER BRINE TANKS			
REF.	MODEL	COLOURS	
T0082AWAD	JOKER A	WHITE WITH BLACK COVER	
T0082AWAA	JOKER A	WHITE WITH BLUE COVER	
T0082AWAW	JOKER A	WHITE WITH WHITE COVER	
T0082BWBD	JOKER B	WHITE WITH BLACK COVER	
T0082BWBA	JOKER B	WHITE WITH BLUE COVER	
T0082BWBW	JOKER B	WHITE WITH WHITE COVER	

ACCESSORIE				
REF.	DESCRIPTION	DIAMETER (mm)	HEIGHT (mm)	
PA005	BRINE WELL	100	820	

Cabinets for Softeners New Series



- cabinets for residential softeners;
- materials: tank in HDPE, salt lid in polystyrene;
- standard colours:
- white tank and white salt lid;
- other colours available:
- grey tank and black salt lid;
- on demand and for quantities we can realize customized colours;
- EU design patent no. 003156272.



REF.	MODEL	WIDTH (mm)	LENGTH (mm)	HEIGHT (mm)	WITH MWG TANK	
C0717NWXXS	NEWMINI	320	500	435	7 x 17	
C0817NWXXS	NEWMINI	320	500	435	8 x 17	
C0917NWXXS	NEWMINI	320	500	435	9 x 17	
C1017NWXXS	NEWMINI	320	500	435	10 x 17	
C0730NWXXS	NEWMIDI	320	500	775	7 x 30	
C0830NWXXS	NEWMIDI	320	500	775	8 x 30	
C0930NWXXS	NEWMIDI	320	500	775	9 x 30	
C1030NWXXS	NEWMIDI	320	500	775	10 x 30	
C0735NWXXS	NEWMAXI	320	500	895	7 x 35	
C0835NWXXS	NEWMAXI	320	500	895	8 x 35	
C0935NWXXS	NEWMAXI	320	500	895	9 x 35	
C1035NWXXS	NEWMAXI	320	500	895	10 x 35	

ACCESSORIES

REF.	DESCRIPTION	DIAMETER (mm)	HEIGHT (mm)	
PA003	BRINE WELL FOR NEWMINI	100	342	
PA010	BRINE WELL FOR NEWMIDI	100	690	
PA005	BRINE WELL FOR NEWMAXI	100	820	

Cabinets for Softeners “Mini” - “Maxi” Series



- cabinets for residential softeners;
- materials: tank in HDPE, salt lid in polystyrene;
- standard colours:
- white tank and white salt lid;
- other colours available:
- grey tank and black salt lid;
- on demand and for quantities we can realize customized colours;
- EU design patent no. 003156272.



REF.	MODEL	WIDTH (mm)	LENGTH (mm)	HEIGHT (mm)	WITH MWG TANK	
C0717EWXXS	MINI	320	500	435	7 x 17	
C0817EWXXS	MINI	320	500	435	8 x 17	
C0917EWXXS	MINI	320	500	435	9 x 17	
C1017EWXXS	MINI	320	500	435	10 x 17	
C0735EWXXS	MAXI	320	500	895	7 x 35	
C0835EWXXS	MAXI	320	500	895	8 x 35	
C0935EWXXS	MAXI	320	500	895	9 x 35	
C1035EWXXS	MAXI	320	500	895	10 x 35	

ACCESSORIES

REF.	DESCRIPTION	DIAMETER (mm)	HEIGHT (mm)	
PA003	BRINE WELL FOR MINI	100	342	
PA005	BRINE WELL FOR MAXI	100	820	



Brine tanks



Residential Square Brine Tank



- Made in European Union (Italy);
- Brine tank material HDPE;
- Complete with cover in ABS;
- Dimensions 380 x 380 mm, height 790 mm;
- Capacity 85 liters;
- Available multiple packaging of 30 pcs per pallet;
- EU design patent no. 003156272.



REF.	TANK COLOUR	COVER COLOUR	
T0085QWQA	White	Blue	
T0085QWQW	White	White	
T0085QWQD	White	Black	

Accessories:

Salt Grid

- Made in European Union (Italy);
- Material HDPE;
- Height 200 mm;
- Hole for brine well diameter 100 mm;
- Salt gride holes \square 3 mm.



REF.	
PC006	

Brine well

- Material PVC with cover;
- Diameter 100 mm;
- Height 640 mm.

REF.	
PA007	



Residential Round Brine Tanks



- Made in European Union (Italy);
- Brine tanks complete with cover;
- Material HDPE, rotomolded;
- Single or multiple packaging of 20 pcs per pallet for 100 liters and 140 liters brine tanks and 16 pcs per pallet for 190 liters brine tanks;
- Colour white opaque UVA ray resistant;
- Cover colours available: white, blue or black;
- EU design patent no. 003156272.

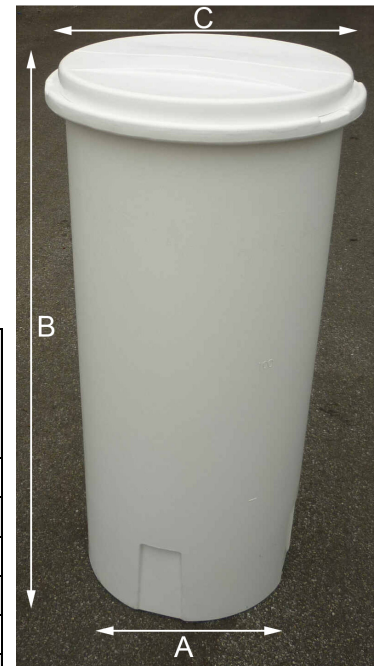

REF.	CAPACITY (LITERS)	COVER COLOUR	OVERALL DIMENSIONS		
			A (mm)	B (mm)	C (mm)
T0100CWCW	100	White	460	616	565
T0100CWCA	100	Blue	460	616	565
T0100CWCD	100	Black	460	616	565
T0140CWCW	140	White	460	843	565
T0140CWCA	140	Blue	460	843	565
T0140CWCD	140	Black	460	843	565
T0190CWCW	190	White	460	1123	565
T0190CWCA	190	Blue	460	1123	565
T0190CWCD	190	Black	460	1123	565

Accessories:

Salt grids

- Made in European Union (Italy);
- Material HDPE;
- Hole for brine well diameter 100 mm;
- Salt gride holes \square 3 mm.



REF.	HEIGHT (mm)	DIAMETER (mm)
PC031	130	475
PC032	200	475
PC033	270	475



Brine well

- Material PVC with cover;
- Diameter 100 mm.

REF.	HEIGHT (mm)	FOR BRINE TANKS (liters)
PA075	520	100
PA010	690	140
PA015	970	190

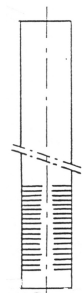

Industrial Round Brine Tanks



- Made in European Union (Italy);
- Brine tanks complete with cover;
- Material HDPE, rotomolded;
- Single or multiple packaging of 3 pcs per pallet;
- Colour white opaque UVA ray resistant;
- Cover colours available: white, blue or black;
- EU design patent no. 003156272.

REF.	CAPACITY (LITERS)	COVER COLOUR	OVERALL DIMENSIONS		
			A (mm)	B (mm)	C (mm)
T0340CWCW	340	White	594	1200	723
T0340CWCA	340	Blue	594	1200	723
T0340CWCD	340	Black	594	1200	723
T0460CWCW	460	White	703	1196	833
T0460CWCA	460	Blue	703	1196	833
T0460CWCD	460	Black	703	1196	833

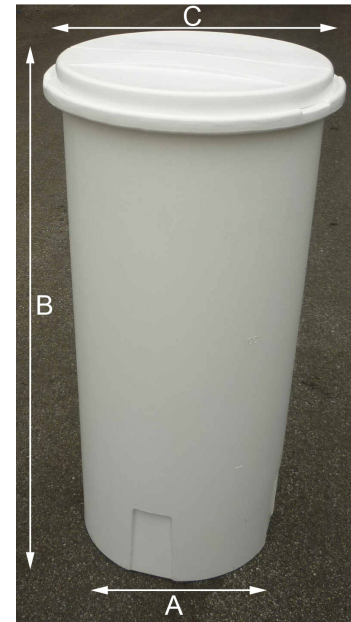

Accessories:

Salt grids

- Made in European Union (Italy);
- Material HDPE;
- Hole for brine well diameter 160 mm;
- Salt gride holes $\varnothing = 5$ mm.

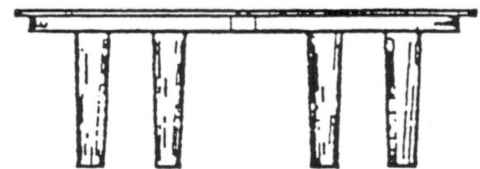

REF.	HEIGHT (mm)	DIAMETER (mm)	FOR BRINE TANKS (liters)
PC070	375	600	340
PC071	375	700	460

Brine well

- Material PVC with cover;
- Diameter 160 mm;
- Height 1050 mm.

REF.	
PA016	



Industrial Round Brine Tanks



- Made in European Union (Italy);
- Brine tanks complete with cover;
- Material HDPE, rotomolded;
- Single or multiple packaging of 3 pcs per pallet;
- Colour white opaque UVA ray resistant;
- Cover colours available: white, blue or black;
- EU design patent no. 003156272.

REF.	CAPACITY (LITERS)	COVER COLOUR	OVERALL DIMENSIONS		
			A (mm)	B (mm)	C (mm)
T0670CWCW	670	White	847	1196	973
T0670CWCA	670	Blue	847	1196	973
T0670CWCD	670	Black	847	1196	973
T0920CWCW	920	White	997	1206	1123
T0920CWCA	920	Blue	997	1206	1123
T0920CWCD	920	Black	997	1206	1123

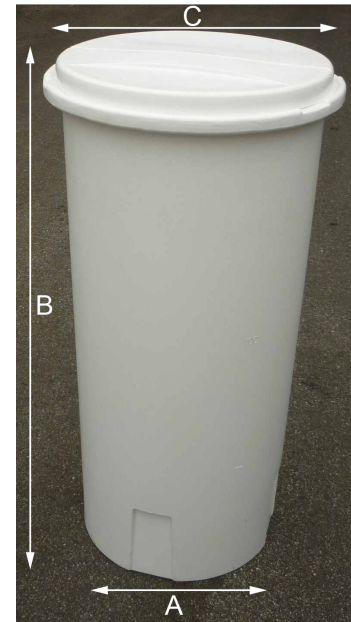

Accessories:

Salt grids

- Made in European Union (Italy);
- Material HDPE;
- Hole for brine well diameter 160 mm;
- Salt gride holes $\varnothing = 5$ mm.

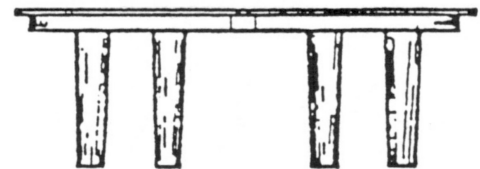

REF.	HEIGHT (mm)	DIAMETER (mm)	FOR BRINE TANKS (liters)
PC072	375	835	670
PC073	375	1010	920

Brine well

- Material PVC with cover;
- Diameter 160 mm;
- Height 1050 mm.

REF.	
PA016	



Potassium Permanganate Feeder



- feeder for potassium permanganate solution, to realize automatic iron removal systems with manganese greensand;
- complete with floating valve, well, special grid for permanganate, overflow, safety screw for cover;
- material: polyethylene;
- dimensions: diameter 266 mm, height 420 mm;
- storage KMnO_4 capacity: 13,6 kg;
- connection for $\frac{3}{8}$ " tubing;
- colour black.

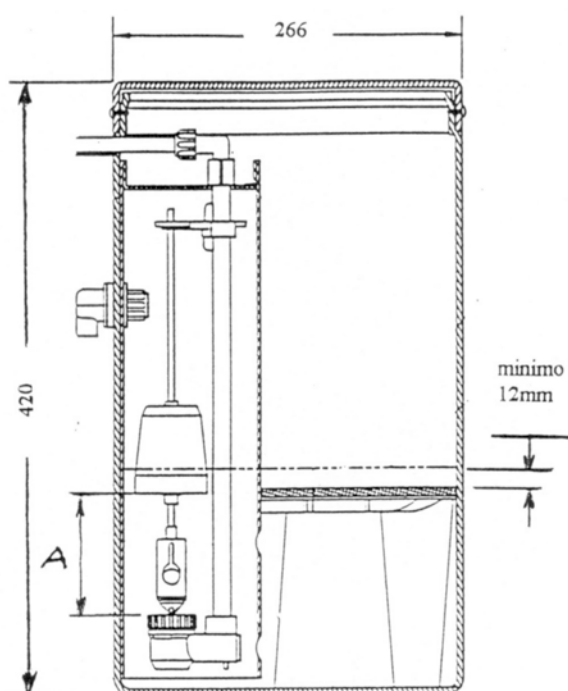

REF.	
AV120	

Float setting:

Suggested dose of regenerant: 2 ÷ 4 g KMnO_4 per greensand liter

KMnO_4 solution: 30 g/l at 10°C
60 g/l at 22°C

Minimum A floating setting at 108 mm is equivalent to 4 liters of solution.



Membranes
reverse
osmosis
and Ultra
Filtration



CSM 2 ½” Membranes



LOW PRESSURE LPM MEMBRANES					
REF.	OLD REF.	MODEL	NSF/ANSI	DM174-2004	PRICE EURO
MCRE2514-TL	DC060	RE2514-TL	-	Compliant	
MCRE2514-TLF	DC061	RE2514-TLF	-	Compliant	
MCRE2521-BLN	DC062	RE2521-BLN	-	Compliant	
MCRE2521-BLF	DC063	RE2521-BLF	-	Compliant	
MCRE2540-BLN	DC064	RE2540-BLN	-	Compliant	
MCRE2540-BLF	DC065	RE2540-BLF	-	Compliant	
MCRE2540-BLR	DC066	RE2540-BLR	-	Compliant	

BRACKISH WATER BWM MEMBRANES					
REF.	OLD REF.	MODEL	NSF/ANSI	DM174-2004	
MCRE2521-BE	DC070	RE2521-BE	-	Compliant	
MCRE2540-BE	DC071	RE2540-BE	-	Compliant	

CHLORINE RESISTANT CRM MEMBRANES					
REF.	OLD REF.	MODEL	NSF/ANSI	DM174-2004	
MCRE2540-CE (*)	DC072	RE2540-CE	-	Compliant	

FOULING RESISTANT FRM MEMBRANES					
REF.	OLD REF.	MODEL	NSF/ANSI	DM174-2004	
MCRE2540-FEN	DC075	RE2540-FEn	-	Compliant	

SEA WATER SWM MEMBRANES					
REF.	OLD REF.	MODEL	NSF/ANSI	DM174-2004	
MCRE2521-SHF	DC080A	RE2521-SHF	-	Compliant	
MCRE2540-SHN	DC081	RE2540-SHN	-	Compliant	
MCRE2540-SHF	DC082	RE2540-SHF	-	Compliant	

NANOFILTRATION NFM MEMBRANES					
REF.	OLD REF.	MODEL	NSF/ANSI	DM174-2004	
MCNE2540-90	DC086	NE2540-90	-	Compliant	

(*) not available in stock.

CSM 2 1/2" Membranes



Ref. MCRE2514-TL

RE2514-TL

RO element for brackish water

CSM[®]

SPECIFICATIONS:

General Features	Permeate flow rate:	250 GPD (0.94 m ³ /day)
	Stabilized salt rejection:	97.5%
	Effective membrane area:	7 ft ² (0.65 m ²)

1. The stated product performance is based on data taken after 30 minutes of operation at the following test conditions:

- 1,500 mg/L NaCl solution at 150 psig (1.0 MPa) applied pressure
- 15% recovery
- 77 °F (25 °C)
- pH 6.5–7.0

2. Minimum salt rejection is 99.0%.

3. Permeate flow rate for each element may vary but will be no more than 15%.

4. All elements are vacuum sealed in a polyethylene bag containing 1.0% SBS (sodium bisulfite) solution and individually packaged in a cardboard box.

Membrane type:	Thin-Film Composite
Membrane material:	Polyamide (PA)
Element configuration:	Spiral-Wound, FRP Wrapping

Dimensions

Model Name	A	B	C	D	E	Part Number	
						Inter-connector	Brine Seal
RE2514-TL	14.0 inch (356 mm)	2.4 inch (61 mm)	0.75 inch (19.1 mm)	1.18 inch (30 mm)	1.18 inch (30 mm)	DD004 (*)	DC005 (*)

(*) see 05-03-99-EN data sheet.



1. Each membrane element comes with one brine seal, one interconnector (coupler) and four o-rings.

The information provided in this document is solely for informative purposes. It is the user's responsibility to ensure the appropriate usage of this product. Woongjin Chemical assumes no obligation, liability or damages incurred for the misuse of the product or for the information provided in this document. This document does not express or implies any warranty as to the merchantability or fitness of the product.



RE25 I4-TL

RO element for brackish water

CSM[®]

APPLICATION DATA:

Operating Limits

· Max. Pressure Drop / Element	15 psi (0.1 MPa)
· Max. Operating Pressure	600 psi (4.14 MPa)
· Max. Feed Flow Rate	6 gpm (1.36 m ³ /hr)
· Min. Concentrate Flow Rate	1 gpm (0.23 m ³ /hr)
· Max. Operating Temperature	113 °F (45 °C)
· Operating pH Range	2.0–11.0
· CIP pH Range	1.0–13.0
· Max. Turbidity	1.0 NTU
· Max. SDI (15 min)	5.0
· Max. Chlorine Concentration	< 0.1 mg/L

Design Guidelines for Various Water Sources

· Wastewater Conventional (SDI < 5)	8–12 gfd
· Wastewater Pretreated by UF/MF (SDI < 3)	10–14 gfd
· Seawater, Open Intake (SDI < 5)	7–10 gfd
· Seawater, Beach Well (SDI < 3)	8–12 gfd
· Surface Water (SDI < 5)	12–16 gfd
· Surface Water (SDI < 3)	13–17 gfd
· Well water (SDI < 3)	13–17 gfd
· RO permeate (SDI < 1)	21–30 gfd

Saturation Limits (Using Antiscalants)[†]

· Langelier Saturation Index (LSI)	<+1.5
· Stiff and Davis Saturation Index (SDSI)	<+0.5
· CaSO ₄	230% saturation
· SrSO ₄	800% saturation
· BaSO ₄	6,000% saturation
· SiO ₂	100% saturation

[†]The above saturation limits are typically accepted by proprietary antiscalant manufacturers. It is the user's responsibility to ensure proper chemical(s) and concentration are dosed ahead of the membrane system to prevent scale formation anywhere within the membrane system. Membrane elements fouled or damaged due to scale formation are not covered by the limited warranty.

GENERAL HANDLING PROCEDURES

- Elements contained in the boxes must be kept dry at room temperature (7–32°C; 40–95°F) and should not be stored in direct sunlight. If the polyethylene bag is damaged, a new preservative solution (sodium bisulfite) must be added and air-tight sealed to prevent drying and biological growth.
- Permeate from the first hour of operation should be discarded to flush out the preservative solution.
- Elements should be immersed in a preservative solution during storage, shipping and system shutdowns to prevent biological growth and freezing. The standard storage solution contains 1% by weight sodium bisulfite or sodium metabisulfite (food grade). For short term storage (i.e. one week or less) 1% by weight sodium metabisulfite solution is adequate for preventing biological growth.
- Keep elements moist at all times after initial wetting.
- Avoid excessive pressure and flow spikes.
- Only use chemicals compatible with the membrane elements and components. Use of such chemicals may void the element limited warranty.
- Permeate pressure must always be equal or less than the feed/concentrate pressure. Damage caused by permeate back pressure voids the element limited warranty.

CSM 2 1/2" Membranes



Ref. MCRE2514-TLF

RE2514-TLF

RO element for brackish water

CSM

SPECIFICATIONS:

General Features	Permeate flow rate:	250 GPD (0.94 m ³ /day)
	Stabilized salt rejection:	96.5%
	Effective membrane area:	7 ft ² (0.65 m ²)

1. The stated product performance is based on data taken after 30 minutes of operation at the following test conditions:

- 500 mg/L NaCl solution at 100 psig (0.7 MPa) applied pressure
- 15% recovery
- 77 °F (25 °C)
- pH 6.5–7.0

2. Minimum salt rejection is 99.0%.

3. Permeate flow rate for each element may vary but will be no more than 15%.

4. All elements are vacuum sealed in a polyethylene bag containing 1.0% SBS (sodium bisulfite) solution and individually packaged in a cardboard box.

Membrane type:	Thin-Film Composite
Membrane material:	Polyamide (PA)
Element configuration:	Spiral-Wound, FRPW wrapping

Dimensions

Model Name	A	B	C	D	E	Part Number	
						Inter-connector	Brine Seal
RE2514-TLF	14.0 inch (356 mm)	2.4 inch (61 mm)	0.75 inch (19.1 mm)	1.18 inch (30 mm)	1.18 inch (30 mm)	DD004 (*)	DC005 (*)

(*) see 05-03-99-EN data sheet.

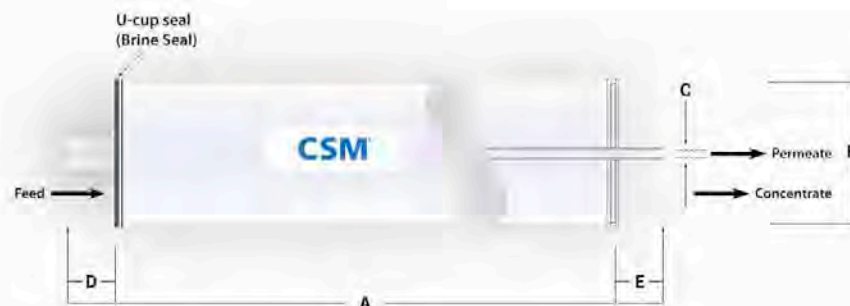

1. Each membrane element comes with one brine seal, one interconnector (coupler) and four o-rings.

The information provided in this document is solely for informative purposes. It is the user's responsibility to ensure the appropriate usage of this product. Woongjin Chemical assumes no obligation, liability or damages incurred for the misuse of the product or for the information provided in this document. This document does not express or imply any warranty as to the merchantability or fitness of the product.



RE25 I4-TLF

RO element for brackish water

CSM[®]

APPLICATION DATA:

Operating Limits

· Max. Pressure Drop / Element	15 psi (0.1 MPa)
· Max. Operating Pressure	600 psi (4.14 MPa)
· Max. Feed Flow Rate	6 gpm (1.36 m ³ /hr)
· Min. Concentrate Flow Rate	1 gpm (0.23 m ³ /hr)
· Max. Operating Temperature	113 °F (45 °C)
· Operating pH Range	2.0–11.0
· CIP pH Range	1.0–13.0
· Max. Turbidity	1.0 NTU
· Max. SDI (15 min)	5.0
· Max. Chlorine Concentration	< 0.1 mg/L

Design Guidelines for Various Water Sources

· Wastewater Conventional (SDI < 5)	8–12 gfd
· Wastewater Pretreated by UF/MF (SDI < 3)	10–14 gfd
· Seawater, Open Intake (SDI < 5)	7–10 gfd
· Seawater, Beach Well (SDI < 3)	8–12 gfd
· Surface Water (SDI < 5)	12–16 gfd
· Surface Water (SDI < 3)	13–17 gfd
· Well water (SDI < 3)	13–17 gfd
· RO permeate (SDI < 1)	21–30 gfd

Saturation Limits (Using Antiscalants)[†]

· Langelier Saturation Index (LSI)	<+1.5
· Stiff and Davis Saturation Index (SDSI)	<+0.5
· CaSO ₄	230% saturation
· SrSO ₄	800% saturation
· BaSO ₄	6,000% saturation
· SiO ₂	100% saturation

[†]The above saturation limits are typically accepted by proprietary antiscalant manufacturers. It is the user's responsibility to ensure proper chemical(s) and concentration are dosed ahead of the membrane system to prevent scale formation anywhere within the membrane system. Membrane elements fouled or damaged due to scale formation are not covered by the limited warranty.

GENERAL HANDLING PROCEDURES

- Elements contained in the boxes must be kept dry at room temperature (7–32°C; 40–95°F) and should not be stored in direct sunlight. If the polyethylene bag is damaged, a new preservative solution (sodium bisulfite) must be added and air-tight sealed to prevent drying and biological growth.
- Permeate from the first hour of operation should be discarded to flush out the preservative solution.
- Elements should be immersed in a preservative solution during storage, shipping and system shutdowns to prevent biological growth and freezing. The standard storage solution contains 1% by weight sodium bisulfite or sodium metabisulfite (food grade). For short term storage (i.e. one week or less) 1% by weight sodium metabisulfite solution is adequate for preventing biological growth.
- Keep elements moist at all times after initial wetting.
- Avoid excessive pressure and flow spikes.
- Only use chemicals compatible with the membrane elements and components. Use of such chemicals may void the element limited warranty.
- Permeate pressure must always be equal or less than the feed/concentrate pressure. Damage caused by permeate back pressure voids the element limited warranty.

CSM 2 1/2" Membranes



Ref. MCRE2521-BLN

RE2521-BLN

Low pressure grade RO element for brackish water

CSM

SPECIFICATIONS:

General Features	Permeate flow rate:	300 GPD (1.1 m ³ /day)
	Stabilized salt rejection:	99.2%
	Effective membrane area:	12 ft ² (1.1 m ²)

1. The stated product performance is based on data taken after 30 minutes of operation at the following test conditions:

- 1,500 mg/L NaCl solution at 150 psig (1.0 MPa) applied pressure
- 15% recovery
- 77 °F (25 °C)
- pH 6.5–7.0

2. Minimum salt rejection is 99.0%.

3. Permeate flow rate for each element may vary but will be no more than 15%.

4. All elements are vacuum sealed in a polyethylene bag containing 1.0% SBS (sodium bisulfite) solution and individually packaged in a cardboard box.

Membrane type:	Thin-Film Composite
Membrane material:	Polyamide (PA)
Element configuration:	Spiral-Wound, FRP Wrapping

Dimensions

Model Name	A	B	C	D	E	Part Number	
						Inter-connector	Brine Seal
RE2521-BLN	21.0 inch (534 mm)	2.5 inch (64 mm)	0.75 inch (19.1 mm)	1.1 inch (28 mm)	1.1 inch (28 mm)	DD004 (*)	DC005 (*)

(*) see 05-03-99-EN data sheet.



1. Each membrane element supplied with one brine seal, one interconnector (coupler) and four o-rings.
2. All RE2521 elements fit nominal 2.5 inch (64 mm) I.D. pressure vessels.

The information provided in this document is solely for informative purposes. It is the user's responsibility to ensure the appropriate usage of this product. Woongjin Chemical assumes no obligation, liability or damages incurred for the misuse of the product or for the information provided in this document. This document does not express or imply any warranty as to the merchantability or fitness of the product.



RE252 I-BLN

Low pressure grade RO element for brackish water

CSM[®]

APPLICATION DATA:

Operating Limits

· Max. Pressure Drop / Element	15 psi (0.1 MPa)
· Max. Pressure Drop / 240" Vessel	60 psi (0.41 MPa)
· Max. Operating Pressure	600 psi (4.14 MPa)
· Max. Feed Flow Rate	6 gpm (1.36 m ³ /hr)
· Min. Concentrate Flow Rate	1 gpm (0.23 m ³ /hr)
· Max. Operating Temperature	113 °F (45 °C)
· Operating pH Range	2.0–11.0
· CIP pH Range	1.0–13.0
· Max. Turbidity	1.0 NTU
· Max. SDI (15 min)	5.0
· Max. Chlorine Concentration	< 0.1 mg/L

Design Guidelines for Various Water Sources

· Wastewater Conventional (SDI < 5)	8–12 gfd
· Wastewater Pretreated by UF/MF (SDI < 3)	10–14 gfd
· Seawater, Open Intake (SDI < 5)	7–10 gfd
· Seawater, Beach Well (SDI < 3)	8–12 gfd
· Surface Water (SDI < 5)	12–16 gfd
· Surface Water (SDI < 3)	13–17 gfd
· Well water (SDI < 3)	13–17 gfd
· RO permeate (SDI < 1)	21–30 gfd

Saturation Limits (Using Antiscalants)[†]

· Langelier Saturation Index (LSI)	<+ 1.5
· Stiff and Davis Saturation Index (SDSI)	<+0.5
· CaSO ₄	230% saturation
· SrSO ₄	800% saturation
· BaSO ₄	6,000% saturation
· SiO ₂	100% saturation

[†]The above saturation limits are typically accepted by proprietary antiscalant manufacturers. It is the user's responsibility to ensure proper chemical(s) and concentration are dosed ahead of the membrane system to prevent scale formation anywhere within the membrane system. Membrane elements fouled or damaged due to scale formation are not covered by the limited warranty.

GENERAL HANDLING PROCEDURES

- Elements contained in the boxes must be kept dry at room temperature (7–32°C; 40–95°F) and should not be stored in direct sunlight. If the polyethylene bag is damaged, a new preservative solution (sodium bisulfite) must be added and air-tight sealed to prevent drying and biological growth.
- Permeate from the first hour of operation should be discarded to flush out the preservative solution.
- Elements should be immersed in a preservative solution during storage, shipping and system shutdowns to prevent biological growth and freezing. The standard storage solution contains 1% by weight sodium bisulfite or sodium metabisulfite (food grade). For short term storage (i.e. one week or less) 1% by weight sodium metabisulfite solution is adequate for preventing biological growth.
- Keep elements moist at all times after initial wetting.
- Avoid excessive pressure and flow spikes.
- Only use chemicals compatible with the membrane elements and components. Use of such chemicals may void the element limited warranty.
- Permeate pressure must always be equal or less than the feed/concentrate pressure. Damage caused by permeate back pressure voids the element limited warranty.

CSM 2 1/2" Membranes



Ref. MCRE2521-BLF

RE2521-BLF

Ultra-low pressure RO element for low TDS water

CSM

SPECIFICATIONS:

General Features	Permeate flow rate:	350 GPD (1.3 m ³ /day)
	Stabilized salt rejection:	99.2%
	Effective membrane area:	12 ft ² (1.1 m ²)

1. The stated product performance is based on data taken after 30 minutes of operation at the following test conditions:

- 500 mg/L NaCl solution at 100 psig (0.7 MPa) applied pressure
- 8% recovery
- 77 °F (25 °C)
- pH 6.5–7.0

2. Minimum salt rejection is 99.0%.

3. Permeate flow rate for each element may vary but will be no more than 15%.

4. All elements are vacuum sealed in a polyethylene bag containing 1.0% SBS (sodium bisulfite) solution and individually packaged in a cardboard box.

Membrane type:	Thin-Film Composite
Membrane material:	Polyamide (PA)
Element configuration:	Spiral-Wound, FRP Wrapping

Dimensions

Model Name	A	B	C	D	E	Part Number	
						Inter-connector	Brine Seal
RE2521-BLF	21.0 inch (534 mm)	2.5 inch (64 mm)	0.75 inch (19.1 mm)	1.1 inch (28 mm)	1.1 inch (28 mm)	DD004 (*)	DC005 (*)

(*) see 05-03-99-EN data sheet.



1. Each membrane element supplied with one brine seal, one interconnector (coupler) and four o-rings.
2. All RE2521 elements fit nominal 2.5 inch (64 mm) I.D. pressure vessels.

The information provided in this document is solely for informative purposes. It is the user's responsibility to ensure the appropriate usage of this product. Woongjin Chemical assumes no obligation, liability or damages incurred for the misuse of the product or for the information provided in this document. This document does not express or implies any warranty as to the merchantability or fitness of the product.



RE252I-BLF

Ultra-low pressure RO element for low TDS water

CSM[®]

APPLICATION DATA:

Operating Limits

· Max. Pressure Drop / Element	15 psi (0.1 MPa)
· Max. Pressure Drop / 240" Vessel	60 psi (0.41 MPa)
· Max. Operating Pressure	600 psi (4.14 MPa)
· Max. Feed Flow Rate	6 gpm (1.36 m ³ /hr)
· Min. Concentrate Flow Rate	1 gpm (0.23 m ³ /hr)
· Max. Operating Temperature	113 °F (45 °C)
· Operating pH Range	2.0–11.0
· CIP pH Range	1.0–13.0
· Max. Turbidity	1.0 NTU
· Max. SDI (15 min)	5.0
· Max. Chlorine Concentration	< 0.1 mg/L

Design Guidelines for Various Water Sources

· Wastewater Conventional (SDI < 5)	8–12 gfd
· Wastewater Pretreated by UF/MF (SDI < 3)	10–14 gfd
· Seawater, Open Intake (SDI < 5)	7–10 gfd
· Seawater, Beach Well (SDI < 3)	8–12 gfd
· Surface Water (SDI < 5)	12–16 gfd
· Surface Water (SDI < 3)	13–17 gfd
· Well water (SDI < 3)	13–17 gfd
· RO permeate (SDI < 1)	21–30 gfd

Saturation Limits (Using Antiscalants)[†]

· Langlier Saturation Index (LSI)	<+1.5
· Stiff and Davis Saturation Index (SDSI)	<+0.5
· CaSO ₄	230% saturation
· SrSO ₄	800% saturation
· BaSO ₄	6,000% saturation
· SiO ₂	100% saturation

[†]The above saturation limits are typically accepted by proprietary antiscalant manufacturers. It is the user's responsibility to ensure proper chemical(s) and concentration are dosed ahead of the membrane system to prevent scale formation anywhere within the membrane system. Membrane elements fouled or damaged due to scale formation are not covered by the limited warranty.

GENERAL HANDLING PROCEDURES

- Elements contained in the boxes must be kept dry at room temperature (7–32°C; 40–95°F) and should not be stored in direct sunlight. If the polyethylene bag is damaged, a new preservative solution (sodium bisulfite) must be added and air-tight sealed to prevent drying and biological growth.
- Permeate from the first hour of operation should be discarded to flush out the preservative solution.
- Elements should be immersed in a preservative solution during storage, shipping and system shutdowns to prevent biological growth and freezing. The standard storage solution contains 1% by weight sodium bisulfite or sodium metabisulfite (food grade). For short term storage (i.e. one week or less) 1% by weight sodium metabisulfite solution is adequate for preventing biological growth.
- Keep elements moist at all times after initial wetting.
- Avoid excessive pressure and flow spikes.
- Only use chemicals compatible with the membrane elements and components. Use of such chemicals may void the element limited warranty.
- Permeate pressure must always be equal or less than the feed/concentrate pressure. Damage caused by permeate back pressure voids the element limited warranty.

CSM 2 ½" Membranes



Ref. MCRE2540-BLN

RE2540-BLN

Low pressure grade RO element for brackish water

CSM[®]

SPECIFICATIONS:

General Features	Permeate flow rate:	800 GPD (3.0 m ³ /day)
	Stabilized salt rejection:	99.2%
	Effective membrane area:	27 ft ² (2.5 m ²)

1. The stated product performance is based on data taken after 30 minutes of operation at the following test conditions:

- 1,500 mg/L NaCl solution at 150 psig (1.0 MPa) applied pressure
- 15% recovery
- 77 °F (25 °C)
- pH 6.5–7.0

2. Minimum salt rejection is 99.0%.

3. Permeate flow rate for each element may vary but will be no more than 10%.

4. All elements are vacuum sealed in a polyethylene bag containing 1.0% SBS (sodium bisulfite) solution and individually packaged in a cardboard box.

Membrane type:	Thin-Film Composite
Membrane material:	Polyamide (PA)
Element configuration:	Spiral-Wound, FRP Wrapping

Dimensions

Model Name	A	B	C	D	E
RE2540-BLN	40.0 inch (1,016 mm)	2.5 inch (64 mm)	0.75 inch (19.1 mm)	1.61 inch (41 mm)	1.61 inch (41 mm)



1. Each membrane element supplied with one brine seal, one interconnector (coupler) and four o-rings.
2. All RE2540 elements fit nominal 2.5 inch (64 mm) I.D. pressure vessels.

The information provided in this document is solely for informative purposes. It is the user's responsibility to ensure the appropriate usage of this product. Woongjin Chemical assumes no obligation, liability or damages incurred for the misuse of the product or for the information provided in this document. This document does not express or imply any warranty as to the merchantability or fitness of the product.



RE2540-BLN

Low pressure grade RO element for brackish water

CSM[®]

APPLICATION DATA:

Operating Limits

· Max. Pressure Drop / Element	15 psi (0.1 MPa)
· Max. Pressure Drop / 240" Vessel	60 psi (0.41 MPa)
· Max. Operating Pressure	600 psi (4.14 MPa)
· Max. Feed Flow Rate	6 gpm (1.36 m ³ /hr)
· Min. Concentrate Flow Rate	1 gpm (0.23 m ³ /hr)
· Max. Operating Temperature	113 °F (45 °C)
· Operating pH Range	2.0–11.0
· CIP pH Range	1.0–13.0
· Max. Turbidity	1.0 NTU
· Max. SDI (15 min)	5.0
· Max. Chlorine Concentration	< 0.1 mg/L

Design Guidelines for Various Water Sources

· Wastewater Conventional (SDI < 5)	8–12 gfd
· Wastewater Pretreated by UF/MF (SDI < 3)	10–14 gfd
· Seawater, Open Intake (SDI < 5)	7–10 gfd
· Seawater, Beach Well (SDI < 3)	8–12 gfd
· Surface Water (SDI < 5)	12–16 gfd
· Surface Water (SDI < 3)	13–17 gfd
· Well water (SDI < 3)	13–17 gfd
· RO permeate (SDI < 1)	21–30 gfd

Saturation Limits (Using Antiscalants)[†]

· Langelier Saturation Index (LSI)	<+ 1.5
· Stiff and Davis Saturation Index (SDSI)	<+0.5
· CaSO ₄	230% saturation
· SrSO ₄	800% saturation
· BaSO ₄	6,000% saturation
· SiO ₂	100% saturation

[†]The above saturation limits are typically accepted by proprietary antiscalant manufacturers. It is the user's responsibility to ensure proper chemical(s) and concentration are dosed ahead of the membrane system to prevent scale formation anywhere within the membrane system. Membrane elements fouled or damaged due to scale formation are not covered by the limited warranty.

GENERAL HANDLING PROCEDURES

- Elements contained in the boxes must be kept dry at room temperature (7–32°C; 40–95°F) and should not be stored in direct sunlight. If the polyethylene bag is damaged, a new preservative solution (sodium bisulfite) must be added and air-tight sealed to prevent drying and biological growth.
- Permeate from the first hour of operation should be discarded to flush out the preservative solution.
- Elements should be immersed in a preservative solution during storage, shipping and system shutdowns to prevent biological growth and freezing. The standard storage solution contains 1% by weight sodium bisulfite or sodium metabisulfite (food grade). For short term storage (i.e. one week or less) 1% by weight sodium metabisulfite solution is adequate for preventing biological growth.
- Keep elements moist at all times after initial wetting.
- Avoid excessive pressure and flow spikes.
- Only use chemicals compatible with the membrane elements and components. Use of such chemicals may void the element limited warranty.
- Permeate pressure must always be equal or less than the feed/concentrate pressure. Damage caused by permeate back pressure voids the element limited warranty.

CSM 2 ½" Membranes



Ref. MCRE2540-BLF

RE2540-BLF

Ultra-low pressure RO element for low TDS water

CSM

SPECIFICATIONS:

General Features	Permeate flow rate:	800 GPD (3.0 m ³ /day)
	Stabilized salt rejection:	99.2%
	Effective membrane area:	27 ft ² (2.5 m ²)

1. The stated product performance is based on data taken after 30 minutes of operation at the following test conditions:

- 500 mg/L NaCl solution at 100 psig (0.7 MPa) applied pressure
- 15% recovery
- 77 °F (25 °C)
- pH 6.5–7.0

2. Minimum salt rejection is 99.0%.

3. Permeate flow rate for each element may vary but will be no more than 10%.

4. All elements are vacuum sealed in a polyethylene bag containing 1.0% SBS (sodium bisulfite) solution and individually packaged in a cardboard box.

Membrane type:	Thin-Film Composite
Membrane material:	Polyamide (PA)
Element configuration:	Spiral-Wound, FRP Wrapping

Dimensions

Model Name	A	B	C	D	E
RE2540-BLF	40.0 inch (1,016 mm)	2.5 inch (64 mm)	0.75 inch (19.1 mm)	1.61 inch (41 mm)	1.61 inch (41 mm)

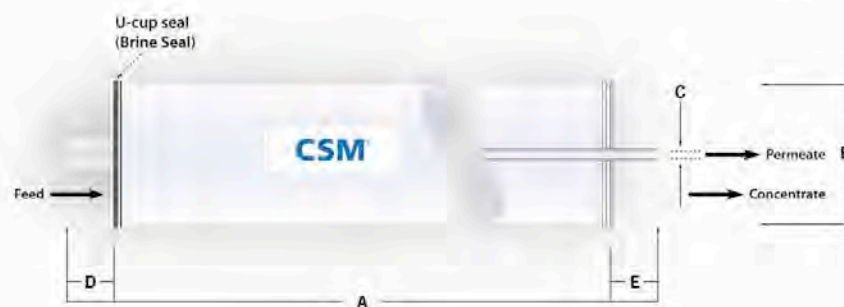

1. Each membrane element supplied with one brine seal, one interconnector (coupler) and four o-rings.
2. All RE2540 elements fit nominal 2.5 inch (64 mm) I.D. pressure vessels.

The information provided in this document is solely for informative purposes. It is the user's responsibility to ensure the appropriate usage of this product. Woongjin Chemical assumes no obligation, liability or damages incurred for the misuse of the product or for the information provided in this document. This document does not express or imply any warranty as to the merchantability or fitness of the product.



RE2540-BLF

Ultra-low pressure RO element for low TDS water

CSM[®]

APPLICATION DATA:

Operating Limits

· Max. Pressure Drop / Element	15 psi (0.1 MPa)
· Max. Pressure Drop / 240" Vessel	60 psi (0.41 MPa)
· Max. Operating Pressure	600 psi (4.14 MPa)
· Max. Feed Flow Rate	6 gpm (1.36 m ³ /hr)
· Min. Concentrate Flow Rate	1 gpm (0.23 m ³ /hr)
· Max. Operating Temperature	113 °F (45 °C)
· Operating pH Range	2.0–11.0
· CIP pH Range	1.0–13.0
· Max. Turbidity	1.0 NTU
· Max. SDI (15 min)	5.0
· Max. Chlorine Concentration	< 0.1 mg/L

Design Guidelines for Various Water Sources

· Wastewater Conventional (SDI < 5)	8–12 gfd
· Wastewater Pretreated by UF/MF (SDI < 3)	10–14 gfd
· Seawater, Open Intake (SDI < 5)	7–10 gfd
· Seawater, Beach Well (SDI < 3)	8–12 gfd
· Surface Water (SDI < 5)	12–16 gfd
· Surface Water (SDI < 3)	13–17 gfd
· Well water (SDI < 3)	13–17 gfd
· RO permeate (SDI < 1)	21–30 gfd

Saturation Limits (Using Antiscalants)[†]

· Langelier Saturation Index (LSI)	<+1.5
· Stiff and Davis Saturation Index (SDSI)	<+0.5
· CaSO ₄	230% saturation
· SrSO ₄	800% saturation
· BaSO ₄	6,000% saturation
· SiO ₂	100% saturation

[†]The above saturation limits are typically accepted by proprietary antiscalant manufacturers. It is the user's responsibility to ensure proper chemical(s) and concentration are dosed ahead of the membrane system to prevent scale formation anywhere within the membrane system. Membrane elements fouled or damaged due to scale formation are not covered by the limited warranty.

GENERAL HANDLING PROCEDURES

- Elements contained in the boxes must be kept dry at room temperature (7–32°C; 40–95°F) and should not be stored in direct sunlight. If the polyethylene bag is damaged, a new preservative solution (sodium bisulfite) must be added and air-tight sealed to prevent drying and biological growth.
- Permeate from the first hour of operation should be discarded to flush out the preservative solution.
- Elements should be immersed in a preservative solution during storage, shipping and system shutdowns to prevent biological growth and freezing. The standard storage solution contains 1% by weight sodium bisulfite or sodium metabisulfite (food grade). For short term storage (i.e. one week or less) 1% by weight sodium metabisulfite solution is adequate for preventing biological growth.
- Keep elements moist at all times after initial wetting.
- Avoid excessive pressure and flow spikes.
- Only use chemicals compatible with the membrane elements and components. Use of such chemicals may void the element limited warranty.
- Permeate pressure must always be equal or less than the feed/concentrate pressure. Damage caused by permeate back pressure voids the element limited warranty.

CSM 2 1/2" Membranes



Ref. MCRE2540-BLR

RE2540-BLR

Low pressure grade RO element for brackish water

CSM[®]

SPECIFICATIONS:

General Features	Permeate flow rate:	600 GPD (2.2 m ³ /day)
	Stabilized salt rejection:	99.6%
	Effective membrane area:	27 ft ² (2.5 m ²)

- The stated product performance is based on data taken after 30 minutes of operation at the following test conditions:
 - 1,500 mg/L NaCl solution at 150 psig (1.0 MPa) applied pressure
 - 15% recovery
 - 77 °F (25 °C)
 - pH 6.5–7.0
- Minimum salt rejection is 99.5%.
- Permeate flow rate for each element may vary but will be no more than 10%.
- All elements are vacuum sealed in a polyethylene bag containing 1.0% SBS (sodium bisulfite) solution and individually packaged in a cardboard box.

Membrane type:	Thin-Film Composite
Membrane material:	Polyamide (PA)
Element configuration:	Spiral-Wound, FRP Wrapping

Dimensions

Model Name	A	B	C	D	E
RE2540-BLR	40.0 inch (1,016 mm)	2.5 inch (64 mm)	0.75 inch (19.1 mm)	1.61 inch (41 mm)	1.61 inch (41 mm)



- Each membrane element supplied with one brine seal, one interconnector (coupler) and four o-rings.
- All RE2540 elements fit nominal 2.5 inch (64 mm) I.D. pressure vessels.

The information provided in this document is solely for informative purposes. It is the user's responsibility to ensure the appropriate usage of this product. Woongjin Chemical assumes no obligation, liability or damages incurred for the misuse of the product or for the information provided in this document. This document does not express or imply any warranty as to the merchantability or fitness of the product.



RE2540-BLR

Low pressure grade RO element for brackish water

CSM[®]

APPLICATION DATA:

Operating Limits

· Max. Pressure Drop / Element	15 psi (0.1 MPa)
· Max. Pressure Drop / 240" Vessel	60 psi (0.41 MPa)
· Max. Operating Pressure	600 psi (4.14 MPa)
· Max. Feed Flow Rate	6 gpm (1.36 m ³ /hr)
· Min. Concentrate Flow Rate	1 gpm (0.23 m ³ /hr)
· Max. Operating Temperature	113 °F (45 °C)
· Operating pH Range	2.0–11.0
· CIP pH Range	1.0–13.0
· Max. Turbidity	1.0 NTU
· Max. SDI (15 min)	5.0
· Max. Chlorine Concentration	< 0.1 mg/L

Design Guidelines for Various Water Sources

· Wastewater Conventional (SDI < 5)	8–12 gfd
· Wastewater Pretreated by UF/MF (SDI < 3)	10–14 gfd
· Seawater, Open Intake (SDI < 5)	7–10 gfd
· Seawater, Beach Well (SDI < 3)	8–12 gfd
· Surface Water (SDI < 5)	12–16 gfd
· Surface Water (SDI < 3)	13–17 gfd
· Well water (SDI < 3)	13–17 gfd
· RO permeate (SDI < 1)	21–30 gfd

Saturation Limits (Using Antiscalants)[†]

· Langelier Saturation Index (LSI)	<+1.5
· Stiff and Davis Saturation Index (SDSI)	<+0.5
· CaSO ₄	230% saturation
· SrSO ₄	800% saturation
· BaSO ₄	6,000% saturation
· SiO ₂	100% saturation

[†]The above saturation limits are typically accepted by proprietary antiscalant manufacturers. It is the user's responsibility to ensure proper chemical(s) and concentration are dosed ahead of the membrane system to prevent scale formation anywhere within the membrane system. Membrane elements fouled or damaged due to scale formation are not covered by the limited warranty.

GENERAL HANDLING PROCEDURES

- Elements contained in the boxes must be kept dry at room temperature (7–32°C; 40–95°F) and should not be stored in direct sunlight. If the polyethylene bag is damaged, a new preservative solution (sodium bisulfite) must be added and air-tight sealed to prevent drying and biological growth.
- Permeate from the first hour of operation should be discarded to flush out the preservative solution.
- Elements should be immersed in a preservative solution during storage, shipping and system shutdowns to prevent biological growth and freezing. The standard storage solution contains 1% by weight sodium bisulfite or sodium metabisulfite (food grade). For short term storage (i.e. one week or less) 1% by weight sodium metabisulfite solution is adequate for preventing biological growth.
- Keep elements moist at all times after initial wetting.
- Avoid excessive pressure and flow spikes.
- Only use chemicals compatible with the membrane elements and components. Use of such chemicals may void the element limited warranty.
- Permeate pressure must always be equal or less than the feed/concentrate pressure. Damage caused by permeate back pressure voids the element limited warranty.

CSM 2 1/2" Membranes



Ref. MCRE2521-BE

RE2521-BE

High productivity RO element for brackish water

CSM

SPECIFICATIONS:

General Features	Permeate flow rate:	300 GPD (1.1 m ³ /day)
	Stabilized salt rejection:	99.7%
	Effective membrane area:	12 ft ² (1.1 m ²)

1. The stated product performance is based on data taken after 30 minutes of operation at the following test conditions:

- 2,000 mg/L NaCl solution at 225 psig (1.5 MPa) applied pressure
- 15% recovery
- 77 °F (25 °C)
- pH 6.5–7.0

2. Minimum salt rejection is 99.4%.

3. Permeate flow rate for each element may vary but will be no more than 15%.

4. All elements are vacuum sealed in a polyethylene bag containing 1.0% SBS (sodium bisulfite) solution and individually packaged in a cardboard box.

Membrane type:	Thin-Film Composite
Membrane material:	Polyamide (PA)
Element configuration:	Spiral-Wound, FRP Wrapping

Dimensions

Model Name	A	B	C	D	E	Part Number	
						Inter-connector	Brine Seal
RE2521-BE	21.0 inch (534 mm)	2.5 inch (64 mm)	0.75 inch (19.1 mm)	1.1 inch (28 mm)	1.1 inch (28 mm)	DD004 (*)	DC005 (*)

(*) see 05-03-99-EN data sheet.



1. Each membrane element comes with one brine seal, one interconnector (coupler) and four o-rings.
2. All RE2521 elements fit nominal 2.5 inch (64 mm) I.D. pressure vessels.

The information provided in this document is solely for informative purposes. It is the user's responsibility to ensure the appropriate usage of this product. Woongjin Chemical assumes no obligation, liability or damages incurred for the misuse of the product or for the information provided in this document. This document does not express or imply any warranty as to the merchantability or fitness of the product.



RE252I-BE

High productivity RO element for brackish water

CSM[®]

APPLICATION DATA:

Operating Limits

· Max. Pressure Drop / Element	15 psi (0.1 MPa)
· Max. Operating Pressure	600 psi (4.14 MPa)
· Max. Feed Flow Rate	6 gpm (1.36 m ³ /hr)
· Min. Concentrate Flow Rate	1 gpm (0.23 m ³ /hr)
· Max. Operating Temperature	113 °F (45 °C)
· Operating pH Range	2.0–11.0
· CIP pH Range	1.0–13.0
· Max. Turbidity	1.0 NTU
· Max. SDI (15 min)	5.0
· Max. Chlorine Concentration	< 0.1 mg/L

Design Guidelines for Various Water Sources

· Wastewater Conventional (SDI < 5)	8–12 gfd
· Wastewater Pretreated by UF/MF (SDI < 3)	10–14 gfd
· Seawater, Open Intake (SDI < 5)	7–10 gfd
· Seawater, Beach Well (SDI < 3)	8–12 gfd
· Surface Water (SDI < 5)	12–16 gfd
· Surface Water (SDI < 3)	13–17 gfd
· Well water (SDI < 3)	13–17 gfd
· RO permeate (SDI < 1)	21–30 gfd

Saturation Limits (Using Antiscalants)[†]

· Langelier Saturation Index (LSI)	<+1.5
· Stiff and Davis Saturation Index (SDSI)	<+0.5
· CaSO ₄	230% saturation
· SrSO ₄	800% saturation
· BaSO ₄	6,000% saturation
· SiO ₂	100% saturation

[†]The above saturation limits are typically accepted by proprietary antiscalant manufacturers. It is the user's responsibility to ensure proper chemical(s) and concentration are dosed ahead of the membrane system to prevent scale formation anywhere within the membrane system. Membrane elements fouled or damaged due to scale formation are not covered by the limited warranty.

GENERAL HANDLING PROCEDURES

- Elements contained in the boxes must be kept dry at room temperature (7–32°C; 40–95°F) and should not be stored in direct sunlight. If the polyethylene bag is damaged, a new preservative solution (sodium bisulfite) must be added and air-tight sealed to prevent drying and biological growth.
- Permeate from the first hour of operation should be discarded to flush out the preservative solution.
- Elements should be immersed in a preservative solution during storage, shipping and system shutdowns to prevent biological growth and freezing. The standard storage solution contains 1% by weight sodium bisulfite or sodium metabisulfite (food grade). For short term storage (i.e. one week or less) 1% by weight sodium metabisulfite solution is adequate for preventing biological growth.
- Keep elements moist at all times after initial wetting.
- Avoid excessive pressure and flow spikes.
- Only use chemicals compatible with the membrane elements and components. Use of such chemicals may void the element limited warranty.
- Permeate pressure must always be equal or less than the feed/concentrate pressure. Damage caused by permeate back pressure voids the element limited warranty.

CSM 2 1/2" Membranes



Ref. MCRE2540-BE

RE2540-BE

High productivity RO element with extended area for brackish water

CSM

SPECIFICATIONS:

General Features	Permeate flow rate:	800 GPD (3.0 m ³ /day)
	Stabilized salt rejection:	99.7%
	Effective membrane area:	27 ft ² (2.5 m ²)

1. The stated product performance is based on data taken after 30 minutes of operation at the following test conditions:

- 2,000 mg/L NaCl solution at 225 psig (1.5 MPa) applied pressure
- 15% recovery
- 77 °F (25 °C)
- pH 6.5–7.0

2. Minimum salt rejection is 99.5%.

3. Permeate flow rate for each element may vary but will be no more than 10%.

4. All elements are vacuum sealed in a polyethylene bag containing 1.0% SBS (sodium bisulfite) solution and individually packaged in a cardboard box.

Membrane type:	Thin-Film Composite
Membrane material:	Polyamide (PA)
Element configuration:	Spiral-Wound, FRP Wrapping

Dimensions

Model Name	A	B	C	D	E
RE2540-BN	40.0 inch (1,016 mm)	2.5 inch (64 mm)	0.75 inch (19.1 mm)	1.61 inch (41 mm)	1.61 inch (41 mm)



1. Each membrane element supplied with one brine seal, one interconnector (coupler) and four o-rings.
2. All RE2540 elements fit nominal 2.5 inch (64 mm) I.D. pressure vessels.

The information provided in this document is solely for informative purposes. It is the user's responsibility to ensure the appropriate usage of this product. Woongjin Chemical assumes no obligation, liability or damages incurred for the misuse of the product or for the information provided in this document. This document does not express or imply any warranty as to the merchantability or fitness of the product.



RE2540-BE

High productivity RO element with extended area for brackish water

CSM[®]

APPLICATION DATA:

Operating Limits

· Max. Pressure Drop / Element	15 psi (0.1 MPa)
· Max. Pressure Drop / 240" Vessel	60 psi (0.41 MPa)
· Max. Operating Pressure	600 psi (4.14 MPa)
· Max. Feed Flow Rate	6 gpm (1.36 m ³ /hr)
· Min. Concentrate Flow Rate	1 gpm (0.23 m ³ /hr)
· Max. Operating Temperature	113 °F (45 °C)
· Operating pH Range	2.0–11.0
· CIP pH Range	1.0–13.0
· Max. Turbidity	1.0 NTU
· Max. SDI (15 min)	5.0
· Max. Chlorine Concentration	< 0.1 mg/L

Design Guidelines for Various Water Sources

· Wastewater Conventional (SDI < 5)	8–12 gfd
· Wastewater Pretreated by UF/MF (SDI < 3)	10–14 gfd
· Seawater, Open Intake (SDI < 5)	7–10 gfd
· Seawater, Beach Well (SDI < 3)	8–12 gfd
· Surface Water (SDI < 5)	12–16 gfd
· Surface Water (SDI < 3)	13–17 gfd
· Well water (SDI < 3)	13–17 gfd
· RO permeate (SDI < 1)	21–30 gfd

Saturation Limits (Using Antiscalants)[†]

· Langelier Saturation Index (LSI)	<+1.5
· Stiff and Davis Saturation Index (SDSI)	<+0.5
· CaSO ₄	230% saturation
· SrSO ₄	800% saturation
· BaSO ₄	6,000% saturation
· SiO ₂	100% saturation

[†]The above saturation limits are typically accepted by proprietary antiscalant manufacturers. It is the user's responsibility to ensure proper chemical(s) and concentration are dosed ahead of the membrane system to prevent scale formation anywhere within the membrane system. Membrane elements fouled or damaged due to scale formation are not covered by the limited warranty.

GENERAL HANDLING PROCEDURES

- Elements contained in the boxes must be kept dry at room temperature (7–32°C; 40–95°F) and should not be stored in direct sunlight. If the polyethylene bag is damaged, a new preservative solution (sodium bisulfite) must be added and air-tight sealed to prevent drying and biological growth.
- Permeate from the first hour of operation should be discarded to flush out the preservative solution.
- Elements should be immersed in a preservative solution during storage, shipping and system shutdowns to prevent biological growth and freezing. The standard storage solution contains 1% by weight sodium bisulfite or sodium metabisulfite (food grade). For short term storage (i.e. one week or less) 1% by weight sodium metabisulfite solution is adequate for preventing biological growth.
- Keep elements moist at all times after initial wetting.
- Avoid excessive pressure and flow spikes.
- Only use chemicals compatible with the membrane elements and components. Use of such chemicals may void the element limited warranty.
- Permeate pressure must always be equal or less than the feed/concentrate pressure. Damage caused by permeate back pressure voids the element limited warranty.

CSM 2 ½" Membranes



Ref. MCRE2540-CE

RE2540-CE

Innovative chlorine resistant RO element for prolonged membrane lifetime

CSM

SPECIFICATIONS:

General Features	Permeate flow rate:	600 GPD (2.3 m ³ /day)
	Stabilized salt rejection:	99.5%
	Effective membrane area:	27 ft ² (2.5 m ²)

1. The stated product performance is based on data taken after 30 minutes of operation at the following test conditions:

- 2,000 mg/L NaCl solution at 225 psig (1.5 MPa) applied pressure
- 15% recovery
- 77 °F (25 °C)
- pH 6.5–7.0

2. Minimum salt rejection is 99.0%.

3. Permeate flow rate for each element may vary but will be no more than 10%.

4. All elements are vacuum sealed in a polyethylene bag containing 1.0% SBS (sodium bisulfite) solution and individually packaged in a cardboard box.

Membrane type:	Thin-Film Composite
Membrane material:	Polyamide (PA)
Element configuration:	Spiral-Wound, FRP Wrapping

Dimensions

Model Name	A	B	C	D	E
RE2540-CE	40.0 inch (1,016 mm)	2.5 inch (64 mm)	0.75 inch (19.1 mm)	1.61 inch (41 mm)	1.61 inch (41 mm)



1. Each membrane element supplied with one brine seal, one interconnector (coupler) and four o-rings.
2. All RE2540 elements fit nominal 2.5 inch (64 mm) I.D. pressure vessels.

The information provided in this document is solely for informative purposes. It is the user's responsibility to ensure the appropriate usage of this product. Woongjin Chemical assumes no obligation, liability or damages incurred for the misuse of the product or for the information provided in this document. This document does not express or implies any warranty as to the merchantability or fitness of the product.



RE2540-CE

Innovative chlorine resistant RO element for prolonged membrane lifetime

CSM®

APPLICATION DATA:

Operating Limits

· Max. Pressure Drop / Element	15 psi (0.1 MPa)
· Max. Pressure Drop / 240" Vessel	60 psi (0.41 MPa)
· Max. Operating Pressure	600 psi (4.14 MPa)
· Max. Feed Flow Rate	6 gpm (1.36 m ³ /hr)
· Min. Concentrate Flow Rate	1 gpm (0.23 m ³ /hr)
· Max. Operating Temperature	113 °F (45 °C)
· Operating pH Range	2.0–11.0
· CIP pH Range	1.0–13.0
· Max. Turbidity	1.0 NTU
· Max. SDI (15 min)	5.0
· Free Chlorine Tolerance	5,000 ppm·hr

Design Guidelines for Various Water Sources

· Wastewater Conventional (SDI < 5)	8–12 gfd
· Wastewater Pretreated by UF/MF (SDI < 3)	10–14 gfd
· Seawater, Open Intake (SDI < 5)	7–10 gfd
· Seawater, Beach Well (SDI < 3)	8–12 gfd
· Surface Water (SDI < 5)	12–16 gfd
· Surface Water (SDI < 3)	13–17 gfd
· Well water (SDI < 3)	13–17 gfd
· RO permeate (SDI < 1)	21–30 gfd

Saturation Limits (Using Antiscalants)[†]

· Langelier Saturation Index (LSI)	<+1.5
· Stiff and Davis Saturation Index (SDSI)	<+0.5
· CaSO ₄	230% saturation
· SrSO ₄	800% saturation
· BaSO ₄	6,000% saturation
· SiO ₂	100% saturation

[†]The above saturation limits are typically accepted by proprietary antiscalant manufacturers. It is the user's responsibility to ensure proper chemical(s) and concentration are dosed ahead of the membrane system to prevent scale formation anywhere within the membrane system. Membrane elements fouled or damaged due to scale formation are not covered by the limited warranty.

GENERAL HANDLING PROCEDURES

- Elements contained in the boxes must be kept dry at room temperature (7–32°C; 40–95°F) and should not be stored in direct sunlight. If the polyethylene bag is damaged, a new preservative solution (sodium bisulfite) must be added and air-tight sealed to prevent drying and biological growth.
- Permeate from the first hour of operation should be discarded to flush out the preservative solution.
- Elements should be immersed in a preservative solution during storage, shipping and system shutdowns to prevent biological growth and freezing. The standard storage solution contains 1% by weight sodium bisulfite or sodium metabisulfite (food grade). For short term storage (i.e. one week or less) 1% by weight sodium metabisulfite solution is adequate for preventing biological growth.
- Keep elements moist at all times after initial wetting.
- Avoid excessive pressure and flow spikes.
- Only use chemicals compatible with the membrane elements and components. Use of such chemicals may void the element limited warranty.
- Permeate pressure must always be equal or less than the feed/concentrate pressure. Damage caused by permeate back pressure voids the element limited warranty.

CSM 2 ½" Membranes



Ref. MCRE2540-FEN

RE2540-FEⁿ

Enhanced fouling resistant RO element for brackish water and wastewater reuse

CSM[®]

SPECIFICATIONS:

General Features	Permeate flow rate:	800 GPD (3.0 m ³ /day)
	Stabilized salt rejection:	99.7%
	Effective membrane area:	27 ft ² (2.5 m ²)

1. The stated product performance is based on data taken after 30 minutes of operation at the following test conditions:

- 2,000 mg/L NaCl solution at 225 psig (1.5 MPa) applied pressure
- 15% recovery
- 77 °F (25 °C)
- pH 6.5–7.0

2. Minimum salt rejection is 99.4%.

3. All elements are vacuum sealed in a polyethylene bag containing 1.0% SBS (sodium bisulfite) solution and individually packaged in a cardboard box.

Membrane type:	Thin-Film Composite
Membrane material:	Polyamide (PA)
Element configuration:	Spiral-Wound, FRP Wrapping

Dimensions

Model Name	A	B	C	D	E
RE2540-FEn	40.0 inch (1,016 mm)	2.5 inch (64 mm)	0.75 inch (19.1 mm)	1.61 inch (41 mm)	1.61 inch (41 mm)



1. Each membrane element supplied with one brine seal, one interconnector (coupler) and four o-rings.
2. All RE2540 elements fit nominal 2.5 inch (64 mm) I.D. pressure vessels.

The information provided in this document is solely for informative purposes. It is the user's responsibility to ensure the appropriate usage of this product. Woongjin Chemical assumes no obligation, liability or damages incurred for the misuse of the product or for the information provided in this document. This document does not express or implies any warranty as to the merchantability or fitness of the product.



RE2540-FEⁿ

CSM[®]

Enhanced fouling resistant RO element for brackish water and wastewater reuse

APPLICATION DATA:

Operating Limits

· Max. Pressure Drop / Element	15 psi (0.1 MPa)
· Max. Pressure Drop / 240" Vessel	60 psi (0.41 MPa)
· Max. Operating Pressure	600 psi (0.42 MPa)
· Max. Feed Flow Rate	6 gpm (1.36 m ³ /hr)
· Min. Concentrate Flow Rate	1 gpm (0.23 m ³ /hr)
· Max. Operating Temperature	113 °F (45 °C)
· Operating pH Range	2.0–11.0
· CIP pH Range	1.0–13.0
· Max. Turbidity	1.0 NTU
· Max. SDI (15 min)	5.0
· Max. Chlorine Concentration	< 0.1 mg/L

Design Guidelines for Various Water Sources

· Wastewater Conventional (SDI < 5)	8–12 gfd
· Wastewater Pretreated by UF/MF (SDI < 3)	10–14 gfd
· Seawater, Open Intake (SDI < 5)	7–10 gfd
· Seawater, Beach Well (SDI < 3)	8–12 gfd
· Surface Water (SDI < 5)	12–16 gfd
· Surface Water (SDI < 3)	13–17 gfd
· Well water (SDI < 3)	13–17 gfd
· RO permeate (SDI < 1)	21–30 gfd

Saturation Limits (Using Antiscalants)[†]

· Langelier Saturation Index (LSI)	<+ 1.5
· Stiff and Davis Saturation Index (SDSI)	<+0.5
· CaSO ₄	230% saturation
· SrSO ₄	800% saturation
· BaSO ₄	6,000% saturation
· SiO ₂	100% saturation

[†]The above saturation limits are typically accepted by proprietary antiscalant manufacturers. It is the user's responsibility to ensure proper chemical(s) and concentration are dosed ahead of the membrane system to prevent scale formation anywhere within the membrane system. Membrane elements fouled or damaged due to scale formation are not covered by the limited warranty.

GENERAL HANDLING PROCEDURES

- Elements contained in the boxes must be kept dry at room temperature (7–32°C; 40–95°F) and should not be stored in direct sunlight. If the polyethylene bag is damaged, a new preservative solution (sodium bisulfite) must be added and air-tight sealed to prevent drying and biological growth.
- Permeate from the first hour of operation should be discarded to flush out the preservative solution.
- Elements should be immersed in a preservative solution during storage, shipping and system shutdowns to prevent biological growth and freezing. The standard storage solution contains 1% by weight sodium bisulfite or sodium metabisulfite (food grade). For short term storage (i.e. one week or less) 1% by weight sodium metabisulfite solution is adequate for preventing biological growth.
- Avoid excessive pressure and flow spikes.
- Only use chemicals compatible with the membrane elements and components. Use of such chemicals may void the element limited warranty.
- Permeate pressure must always be equal or less than the feed/concentrate pressure. Damage caused by permeate back pressure voids the element limited warranty.

CSM 2 1/2" Membranes



Ref. MCRE2521-SHF

RE2521-SHF

High productivity RO element for seawater and high salinity well water

CSM[®]

SPECIFICATIONS:

General Features	Permeate flow rate:	300 GPD (1.14 m ³ /day)
	Nominal salt rejection:	99.7%
	Effective membrane area:	12 ft ² (1.1 m ²)

1. The stated product performance is based on data taken after 30 minutes of operation at the following test conditions:

- 32,000 mg/L NaCl solution at 800 psig (5.5 MPa) applied pressure
- 8% recovery
- 77 °F (25 °C)
- pH 6.5–7.0

2. Minimum salt rejection is 99.6%.

3. Permeate flow rate for each element may vary but will be no more than 20%.

4. All elements are vacuum sealed in a polyethylene bag containing 1.0% SBS (sodium bisulfite) solution and individually packaged in a cardboard box.

Membrane type:	Thin-Film Composite
Membrane material:	Polyamide (PA)
Element configuration:	Spiral-Wound, FRP Wrapping

Dimensions

Model Name	A	B	C	D	E	Part Number	
						Inter-connector	Brine Seal
RE2521-SHF	21.0 inch (534 mm)	2.5 inch (64 mm)	0.75 inch (19.1 mm)	1.1 inch (28 mm)	1.1 inch (28 mm)	DD004 (*)	DC005 (*)

(*) see 05-03-99-EN data sheet.

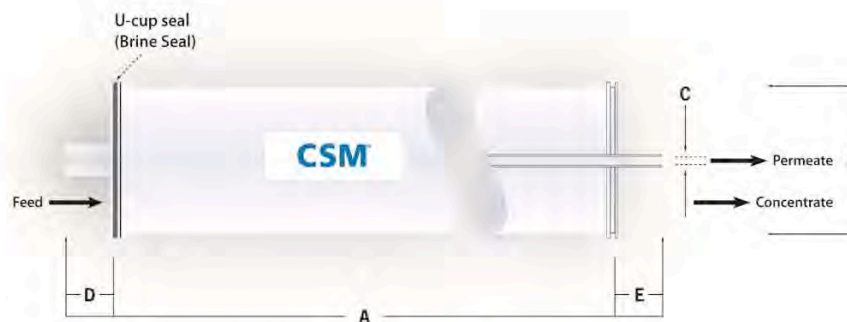

1. Each membrane element supplied with one brine seal, one interconnector (coupler) and four o-rings.
2. All RE2521 elements fit nominal 2.5 inch (64 mm) I.D. pressure vessels.

The information provided in this document is solely for informative purposes. It is the user's responsibility to ensure the appropriate usage of this product. Toray Chemical Korea Inc. assumes no obligation, liability or damages incurred for the misuse of the product or for the information provided in this document. This document does not express or imply any warranty as to the merchantability or fitness of the product.



RE252I-SHF

High rejection RO element for seawater and high salinity well water

APPLICATION DATA:

Operating Limits

· Max. Pressure Drop / Element	15 psi (0.1 MPa)
· Max. Pressure Drop / 240" Vessel	60 psi (0.41 Mpa)
· Max. Operating Pressure	1,200 psi (8.27 MPa)
· Max. Feed Flow Rate	6 gpm (1.36 m ³ /hr)
· Min. Concentrate Flow Rate	1 gpm (0.23 m ³ /hr)
· Max. Operating Temperature	113 °F (45 °C)
· Operating pH Range	2.0–11.0
· CIP pH Range	1.0–13.0
· Max. Turbidity	1.0 NTU
· Max. SDI (15 min)	5.0
· Max. Chlorine Concentration	< 0.1 mg/L

Design Guidelines for Various Water Sources

· Wastewater Conventional (SDI < 5)	8–12 gfd
· Wastewater Pretreated by UF/MF (SDI < 3)	10–14 gfd
· Seawater, Open Intake (SDI < 5)	7–10 gfd
· Seawater, Beach Well (SDI < 3)	8–12 gfd
· Surface Water (SDI < 5)	12–16 gfd
· Surface Water (SDI < 3)	13–17 gfd
· Well water (SDI < 3)	13–17 gfd
· RO permeate (SDI < 1)	21–30 gfd

Saturation Limits (Using Antiscalants)[†]

· Langelier Saturation Index (LSI)	<+1.5
· Stiff and Davis Saturation Index (SDSI)	<+0.5
· CaSO ₄	230% saturation
· SrSO ₄	800% saturation
· BaSO ₄	6,000% saturation
· SiO ₂	100% saturation

[†]The above saturation limits are typically accepted by proprietary antiscalant manufacturers. It is the user's responsibility to ensure proper chemical(s) and concentration are dosed ahead of the membrane system to prevent scale formation anywhere within the membrane system. Membrane elements fouled or damaged due to scale formation are not covered by the limited warranty.

GENERAL HANDLING PROCEDURES

- Elements contained in the boxes must be kept dry at room temperature (7–32°C; 40–95°F) and should not be stored in direct sunlight. If the polyethylene bag is damaged, a new preservative solution (sodium bisulfite) must be added and air-tight sealed to prevent drying and biological growth.
- Permeate from the first hour of operation should be discarded to flush out the preservative solution.
- Elements should be immersed in a preservative solution during storage, shipping and system shutdowns to prevent biological growth and freezing. The standard storage solution contains 1% by weight sodium bisulfite or sodium metabisulfite (food grade). For short term storage (i.e. one week or less) 1% by weight sodium metabisulfite solution is adequate for preventing biological growth.
- Keep elements moist at all times after initial wetting.
- Avoid excessive pressure and flow spikes.
- Only use chemicals compatible with the membrane elements and components. Use of such chemicals may void the element limited warranty.
- Permeate pressure must always be equal or less than the feed/concentrate pressure. Damage caused by permeate back pressure voids the element limited warranty.

CSM 2 1/2" Membranes



Ref. MCRE2540-SHN

RE2540-SHN

High Rejection RO element for seawater and high salinity well water

CSM

SPECIFICATIONS:

General Features	Permeate flow rate:	500 GPD (1.9 m ³ /day)
	Stabilized salt rejection:	99.75%
	Effective membrane area:	24 ft ² (2.2 m ²)

- The stated product performance is based on data taken after 30 minutes of operation at the following test conditions:
 - 32,000 mg/L NaCl solution at 800 psig (5.5 MPa) applied pressure
 - 8% recovery
 - 77 °F (25 °C)
 - pH 6.5–7.0
- Minimum salt rejection is 99.6%.
- Permeate flow rate for each element may vary but will be no more than 15%.
- All elements are vacuum sealed in a polyethylene bag containing 1.0% SBS (sodium bisulfite) solution and individually packaged in a cardboard box.

Membrane type:	Thin-Film Composite
Membrane material:	Polyamide (PA)
Element configuration:	Spiral-Wound, FRP Wrapping

Dimensions

Model Name	A	B	C	D	E
RE2540-SHN	40.0 inch (1,016 mm)	2.5 inch (64 mm)	0.75 inch (19.1 mm)	1.61 inch (41 mm)	1.61 inch (41 mm)



- Each membrane element supplied with one brine seal, one interconnector (coupler) and four o-rings.
- All RE2540 elements fit nominal 2.5 inch (64 mm) I.D. pressure vessels.

The information provided in this document is solely for informative purposes. It is the user's responsibility to ensure the appropriate usage of this product. Woongjin Chemical assumes no obligation, liability or damages incurred for the misuse of the product or for the information provided in this document. This document does not express or imply any warranty as to the merchantability or fitness of the product.



RE2540-SHN

High rejection RO element for seawater and high salinity well water

CSM[®]

APPLICATION DATA:

Operating Limits

· Max. Pressure Drop / Element	15 psi (0.1 MPa)
· Max. Pressure Drop / 240" Vessel	60 psi (0.41 Mpa)
· Max. Operating Pressure	1,200 psi (8.27 MPa)
· Max. Feed Flow Rate	6 gpm (1.36 m ³ /hr)
· Min. Concentrate Flow Rate	1 gpm (0.23 m ³ /hr)
· Max. Operating Temperature	113 °F (45 °C)
· Operating pH Range	2.0–11.0
· CIP pH Range	1.0–13.0
· Max. Turbidity	1.0 NTU
· Max. SDI (15 min)	5.0
· Max. Chlorine Concentration	< 0.1 mg/L

Design Guidelines for Various Water Sources

· Wastewater Conventional (SDI < 5)	8–12 gfd
· Wastewater Pretreated by UF/MF (SDI < 3)	10–14 gfd
· Seawater, Open Intake (SDI < 5)	7–10 gfd
· Seawater, Beach Well (SDI < 3)	8–12 gfd
· Surface Water (SDI < 5)	12–16 gfd
· Surface Water (SDI < 3)	13–17 gfd
· Well water (SDI < 3)	13–17 gfd
· RO permeate (SDI < 1)	21–30 gfd

Saturation Limits (Using Antiscalants)[†]

· Langelier Saturation Index (LSI)	<+1.5
· Stiff and Davis Saturation Index (SDSI)	<+0.5
· CaSO ₄	230% saturation
· SrSO ₄	800% saturation
· BaSO ₄	6,000% saturation
· SiO ₂	100% saturation

[†]The above saturation limits are typically accepted by proprietary antiscalant manufacturers. It is the user's responsibility to ensure proper chemical(s) and concentration are dosed ahead of the membrane system to prevent scale formation anywhere within the membrane system. Membrane elements fouled or damaged due to scale formation are not covered by the limited warranty.

GENERAL HANDLING PROCEDURES

- Elements contained in the boxes must be kept dry at room temperature (7–32°C; 40–95°F) and should not be stored in direct sunlight. If the polyethylene bag is damaged, a new preservative solution (sodium bisulfite) must be added and air-tight sealed to prevent drying and biological growth.
- Permeate from the first hour of operation should be discarded to flush out the preservative solution.
- Elements should be immersed in a preservative solution during storage, shipping and system shutdowns to prevent biological growth and freezing. The standard storage solution contains 1% by weight sodium bisulfite or sodium metabisulfite (food grade). For short term storage (i.e. one week or less) 1% by weight sodium metabisulfite solution is adequate for preventing biological growth.
- Keep elements moist at all times after initial wetting.
- Avoid excessive pressure and flow spikes.
- Only use chemicals compatible with the membrane elements and components. Use of such chemicals may void the element limited warranty.
- Permeate pressure must always be equal or less than the feed/concentrate pressure. Damage caused by permeate back pressure voids the element limited warranty.

CSM 2 ½" Membranes



Ref. MCRE2540-SHF

RE2540-SHF

High productivity RO element for seawater and high salinity well water

CSM

SPECIFICATIONS:

General Features	Permeate flow rate:	600 GPD (2.3 m ³ /day)
	Stabilized salt rejection:	99.7%
	Effective membrane area:	24 ft ² (2.2 m ²)

1. The stated product performance is based on data taken after 30 minutes of operation at the following test conditions:

- 32,000 mg/L NaCl solution at 800 psig (5.5 MPa) applied pressure
- 8% recovery
- 77 °F (25 °C)
- pH 6.5–7.0

2. Minimum salt rejection is 99.6%.

3. Permeate flow rate for each element may vary but will be no more than 15%.

4. All elements are vacuum sealed in a polyethylene bag containing 1.0% SBS (sodium bisulfite) solution and individually packaged in a cardboard box.

Membrane type:	Thin-Film Composite
Membrane material:	Polyamide (PA)
Element configuration:	Spiral-Wound, FRP Wrapping

Dimensions

Model Name	A	B	C	D	E
RE2540-SHF	40.0 inch (1,016 mm)	2.5 inch (64 mm)	0.75 inch (19.1 mm)	1.61 inch (41 mm)	1.61 inch (41 mm)



1. Each membrane element supplied with one brine seal, one interconnector (coupler) and four o-rings.
2. All RE2540 elements fit nominal 2.5 inch (64 mm) I.D. pressure vessels.

The information provided in this document is solely for informative purposes. It is the user's responsibility to ensure the appropriate usage of this product. Woongjin Chemical assumes no obligation, liability or damages incurred for the misuse of the product or for the information provided in this document. This document does not express or imply any warranty as to the merchantability or fitness of the product.



RE2540-SHF

High productivity RO element for seawater and high salinity well water

CSM[®]

APPLICATION DATA:

Operating Limits

· Max. Pressure Drop / Element	15 psi (0.1 MPa)
· Max. Pressure Drop / 240" Vessel	60 psi (0.41 Mpa)
· Max. Operating Pressure	1,200 psi (8.27 MPa)
· Max. Feed Flow Rate	6 gpm (1.36 m ³ /hr)
· Min. Concentrate Flow Rate	1 gpm (0.23 m ³ /hr)
· Max. Operating Temperature	113 °F (45 °C)
· Operating pH Range	2.0–11.0
· CIP pH Range	1.0–13.0
· Max. Turbidity	1.0 NTU
· Max. SDI (15 min)	5.0
· Max. Chlorine Concentration	< 0.1 mg/L

Design Guidelines for Various Water Sources

· Wastewater Conventional (SDI < 5)	8–12 gfd
· Wastewater Pretreated by UF/MF (SDI < 3)	10–14 gfd
· Seawater, Open Intake (SDI < 5)	7–10 gfd
· Seawater, Beach Well (SDI < 3)	8–12 gfd
· Surface Water (SDI < 5)	12–16 gfd
· Surface Water (SDI < 3)	13–17 gfd
· Well water (SDI < 3)	13–17 gfd
· RO permeate (SDI < 1)	21–30 gfd

Saturation Limits (Using Antiscalants)[†]

· Langelier Saturation Index (LSI)	<+1.5
· Stiff and Davis Saturation Index (SDSI)	<+0.5
· CaSO ₄	230% saturation
· SrSO ₄	800% saturation
· BaSO ₄	6,000% saturation
· SiO ₂	100% saturation

[†]The above saturation limits are typically accepted by proprietary antiscalant manufacturers. It is the user's responsibility to ensure proper chemical(s) and concentration are dosed ahead of the membrane system to prevent scale formation anywhere within the membrane system. Membrane elements fouled or damaged due to scale formation are not covered by the limited warranty.

GENERAL HANDLING PROCEDURES

- Elements contained in the boxes must be kept dry at room temperature (7–32°C; 40–95°F) and should not be stored in direct sunlight. If the polyethylene bag is damaged, a new preservative solution (sodium bisulfite) must be added and air-tight sealed to prevent drying and biological growth.
- Permeate from the first hour of operation should be discarded to flush out the preservative solution.
- Elements should be immersed in a preservative solution during storage, shipping and system shutdowns to prevent biological growth and freezing. The standard storage solution contains 1% by weight sodium bisulfite or sodium metabisulfite (food grade). For short term storage (i.e. one week or less) 1% by weight sodium metabisulfite solution is adequate for preventing biological growth.
- Keep elements moist at all times after initial wetting.
- Avoid excessive pressure and flow spikes.
- Only use chemicals compatible with the membrane elements and components. Use of such chemicals may void the element limited warranty.
- Permeate pressure must always be equal or less than the feed/concentrate pressure. Damage caused by permeate back pressure voids the element limited warranty.

CSM 2 ½" Membranes



Ref. MCNE2540-90

NE2540-90

Normal grade NF element with high monovalent ion rejection

CSM[®]

SPECIFICATIONS:

General Features	Permeate flow rate ¹ :	500 GPD (1.9 m ³ /day)
	Monovalent ion rejection (NaCl) ¹ :	85.0 – 95.0%
	Divalent ion rejection (CaCl ₂) ² :	90.0 – 95.0%
	Effective membrane area:	27 ft ² (2.5 m ²)

- The stated product performance is based on data taken after 30 minutes of operation at the following monovalent test conditions:
 - 2,000 mg/L NaCl solution at 75 psig (0.5 MPa) applied pressure
 - 15% recovery
 - 77 °F (25 °C)
 - pH 6.5–7.0
- The stated product performance is based on data taken after 30 minutes of operation at the following divalent test conditions:
 - 500 mg/L CaCl₂ solution at 75 psig (0.5 MPa) applied pressure
 - 15% recovery
 - 77 °F (25 °C)
 - pH 6.5–7.0
- MgSO₄ rejection is 97.0%. (Test conditions are equivalent with NaCl)
- Permeate flow rate for each element may vary but will be no more than 15%.
- All elements are vacuum sealed in a polyethylene bag containing 1.0% SBS (sodium bisulfite) solution and individually packaged in a cardboard box.

Membrane type:	Thin-Film Composite
Membrane material:	Polyamide (PA)
Element configuration:	Spiral-Wound, FRPW Wrapping

Dimensions

Model Name	A	B	C	D	E
NE2540-90	40.0 inch (1,016 mm)	2.5 inch (64 mm)	0.75 inch (19.1 mm)	1.61 inch (41 mm)	1.61 inch (41 mm)



- Each membrane element supplied with one brine seal, one interconnector (coupler) and four o-rings.
- All NE2540 elements fit nominal 2.5 inch (64 mm) I.D. pressure vessels.

The information provided in this document is solely for informative purposes. It is the user's responsibility to ensure the appropriate usage of this product. Woongjin Chemical assumes no obligation, liability or damages incurred for the misuse of the product or for the information provided in this document. This document does not express or implies any warranty as to the merchantability or fitness of the product.



NE2540-90

Normal grade NF element with high monovalent ion rejection

CSM[®]

APPLICATION DATA:

Operating Limits

· Max. Pressure Drop / Element	15 psi (0.1 MPa)
· Max. Pressure Drop / 240" Vessel	60 psi (0.41 Mpa)
· Max. Operating Pressure	600 psi (4.14 MPa)
· Max. Feed Flow Rate	6 gpm (1.36 m ³ /hr)
· Min. Concentrate Flow Rate	1 gpm (0.23 m ³ /hr)
· Max. Operating Temperature	113 °F (45 °C)
· Operating pH Range	2.0–11.0
· CIP pH Range	1.0–13.0
· Max. Turbidity	1.0 NTU
· Max. SDI (15 min)	5.0
· Max. Chlorine Concentration	< 0.1 mg/L

Design Guidelines for Various Water Sources

· Wastewater Conventional (SDI < 5)	8–12 gfd
· Wastewater Pretreated by UF/MF (SDI < 3)	10–14 gfd
· Seawater, Open Intake (SDI < 5)	7–10 gfd
· Seawater, Beach Well (SDI < 3)	8–12 gfd
· Surface Water (SDI < 5)	12–16 gfd
· Surface Water (SDI < 3)	13–17 gfd
· Well water (SDI < 3)	13–17 gfd
· RO permeate (SDI < 1)	21–30 gfd

Saturation Limits (Using Antiscalants)[†]

· Langelier Saturation Index (LSI)	<+1.5
· Stiff and Davis Saturation Index (SDSI)	<+0.5
· CaSO ₄	230% saturation
· SrSO ₄	800% saturation
· BaSO ₄	6,000% saturation
· SiO ₂	100% saturation

[†]The above saturation limits are typically accepted by proprietary antiscalant manufacturers. It is the user's responsibility to ensure proper chemical(s) and concentration are dosed ahead of the membrane system to prevent scale formation anywhere within the membrane system. Membrane elements fouled or damaged due to scale formation are not covered by the limited warranty.

GENERAL HANDLING PROCEDURES

- Elements contained in the boxes must be kept dry at room temperature (7–32°C; 40–95°F) and should not be stored in direct sunlight. If the polyethylene bag is damaged, a new preservative solution (sodium bisulfite) must be added and air-tight sealed to prevent drying and biological growth.
- Permeate from the first hour of operation should be discarded to flush out the preservative solution.
- Elements should be immersed in a preservative solution during storage, shipping and system shutdowns to prevent biological growth and freezing. The standard storage solution contains 1% by weight sodium bisulfite or sodium metabisulfite (food grade). For short term storage (i.e. one week or less) 1% by weight sodium metabisulfite solution is adequate for preventing biological growth.
- Keep elements moist at all times after initial wetting.
- Avoid excessive pressure and flow spikes.
- Only use chemicals compatible with the membrane elements and components. Use of such chemicals may void the element limited warranty.
- Permeate pressure must always be equal or less than the feed/concentrate pressure. Damage caused by permeate back pressure voids the element limited warranty.

CSM 2 1/2" Membranes



Ref. MCNE2540-70

NE2540-70

Normal grade NF element with medium monovalent ion rejection

CSM

SPECIFICATIONS:

General Features	Permeate flow rate ¹ :	450 GPD (1.7 m ³ /day)
	Monovalent ion rejection (NaCl) ¹ :	40.0 – 70.0%
	Divalent ion rejection (CaCl ₂) ² :	45.0 – 70.0%
	Effective membrane area:	27 ft ² (2.5 m ²)

- The stated product performance is based on data taken after 30 minutes of operation at the following monovalent test conditions:
 - 2,000 mg/L NaCl solution at 75 psig (0.5 MPa) applied pressure
 - 15% recovery
 - 77 °F (25 °C)
 - pH 6.5–7.0
- The stated product performance is based on data taken after 30 minutes of operation at the following divalent test conditions:
 - 500 mg/L CaCl₂ solution at 75 psig (0.5 MPa) applied pressure
 - 15% recovery
 - 77 °F (25 °C)
 - pH 6.5–7.0
- MgSO₄ rejection is 97.0%. (Test conditions are equivalent with NaCl)
- Permeate flow rate for each element may vary but will be no more than 15%.
- All elements are vacuum sealed in a polyethylene bag containing 1.0% SBS (sodium bisulfite) solution and individually packaged in a cardboard box.

Membrane type:	Thin-Film Composite
Membrane material:	Polyamide (PA)
Element configuration:	Spiral-Wound, FRP Wrapping

Dimensions

Model Name	A	B	C	D	E
NE2540-70	40.0 inch (1,016 mm)	2.5 inch (64 mm)	0.75 inch (19.1 mm)	1.61 inch (41 mm)	1.61 inch (41 mm)



- Each membrane element supplied with one brine seal, one interconnector (coupler) and four o-rings.
- All NE2540 elements fit nominal 2.5 inch (64 mm) I.D. pressure vessels.

The information provided in this document is solely for informative purposes. It is the user's responsibility to ensure the appropriate usage of this product. Woongjin Chemical assumes no obligation, liability or damages incurred for the misuse of the product or for the information provided in this document. This document does not express or implies any warranty as to the merchantability or fitness of the product.



NE2540-70

Normal grade NF element with medium monovalent ion rejection

CSM[®]

APPLICATION DATA:

Operating Limits

· Max. Pressure Drop / Element	15 psi (0.1 MPa)
· Max. Pressure Drop / 240" Vessel	60 psi (0.41 MPa)
· Max. Operating Pressure	600 psi (4.14 MPa)
· Max. Feed Flow Rate	6 gpm (1.36 m ³ /hr)
· Min. Concentrate Flow Rate	1 gpm (0.23 m ³ /hr)
· Max. Operating Temperature	113 °F (45 °C)
· Operating pH Range	2.0–11.0
· CIP pH Range	1.0–13.0
· Max. Turbidity	1.0 NTU
· Max. SDI (15 min)	5.0
· Max. Chlorine Concentration	< 0.1 mg/L

Design Guidelines for Various Water Sources

· Wastewater Conventional (SDI < 5)	8–12 gfd
· Wastewater Pretreated by UF/MF (SDI < 3)	10–14 gfd
· Seawater, Open Intake (SDI < 5)	7–10 gfd
· Seawater, Beach Well (SDI < 3)	8–12 gfd
· Surface Water (SDI < 5)	12–16 gfd
· Surface Water (SDI < 3)	13–17 gfd
· Well water (SDI < 3)	13–17 gfd
· RO permeate (SDI < 1)	21–30 gfd

Saturation Limits (Using Antiscalants)[†]

· Langlier Saturation Index (LSI)	<+1.5
· Stiff and Davis Saturation Index (SDSI)	<+0.5
· CaSO ₄	230% saturation
· SrSO ₄	800% saturation
· BaSO ₄	6,000% saturation
· SiO ₂	100% saturation

[†]The above saturation limits are typically accepted by proprietary antiscalant manufacturers. It is the user's responsibility to ensure proper chemical(s) and concentration are dosed ahead of the membrane system to prevent scale formation anywhere within the membrane system. Membrane elements fouled or damaged due to scale formation are not covered by the limited warranty.

GENERAL HANDLING PROCEDURES

- Elements contained in the boxes must be kept dry at room temperature (7–32°C; 40–95°F) and should not be stored in direct sunlight. If the polyethylene bag is damaged, a new preservative solution (sodium bisulfite) must be added and air-tight sealed to prevent drying and biological growth.
- Permeate from the first hour of operation should be discarded to flush out the preservative solution.
- Elements should be immersed in a preservative solution during storage, shipping and system shutdowns to prevent biological growth and freezing. The standard storage solution contains 1% by weight sodium bisulfite or sodium metabisulfite (food grade). For short term storage (i.e. one week or less) 1% by weight sodium metabisulfite solution is adequate for preventing biological growth.
- Keep elements moist at all times after initial wetting.
- Avoid excessive pressure and flow spikes.
- Only use chemicals compatible with the membrane elements and components. Use of such chemicals may void the element limited warranty.
- Permeate pressure must always be equal or less than the feed/concentrate pressure. Damage caused by permeate back pressure voids the element limited warranty.

TORAY CSM 4" Membranes



LOW PRESSURE LPM MEMBRANES					
REF.	OLD REF.	MODEL	NSF/ANSI	DM174-2004	
MCRE4021-BLN	DD100	RE4021-BLN	-	Compliant	
MCRE4021-BLF	DD101	RE4021-BLF	-	Compliant	
MCRE4040-BLN	DD102	RE4040-BLN	Standard 61	Compliant	
MCRE4040-BLF	DD103	RE4040-BLF	Standard 61	Compliant	
MCRE4040-BLR	DD104	RE4040-BLR	Standard 61	Compliant	
MTMG10D	-	TMG10D	-	-	

BRACKISH WATER BWM MEMBRANES					
REF.	OLD REF.	MODEL	NSF/ANSI	DM174-2004	
MCRE4021-BE (*)	DD110	RE4021-BE	-	Compliant	
MCRE4040-BE	DD111	RE4040-BE	-	Compliant	
MTM710D	-	TM710D	-	-	

CHLORINE RESISTANT CRM MEMBRANES					
REF.	OLD REF.	MODEL	NSF/ANSI	DM174-2004	
MCRE4040-CE (*)	DD112	RE4040-CE	-	Compliant	

FOULING RESISTANT FRM MEMBRANES					
REF.	OLD REF.	MODEL	NSF/ANSI	DM174-2004	
MCRE4040-FEN	DD115	RE4040-FEn	-	Compliant	
MCRE4040-FL (*)	DD116	RE4040-FL	-	Compliant	
MCRE4040-FLR	DD117	RE4040-FLR	-	Compliant	
MTML10D	-	TML10D	-	-	

SEA WATER SWM MEMBRANES					
REF.	OLD REF.	MODEL	NSF/ANSI	DM174-2004	
MCRE4021-SHN	DD119	RE4021-SHN	-	Compliant	
MTM810C	DD120	TM810C	-	-	
MTM810V	DD121 DD122	TM810V	-	-	

NANOFILTRATION NFM MEMBRANES					
REF.	OLD REF.	MODEL	NSF/ANSI	DM174-2004	
MCNE4040-90	DD125	NE4040-90	-	Compliant	
MCNE4040-70 (*)	DD126	NE4040-70	-	Compliant	
MCNE4040-40 (*)	DD127	NE4040-40	-	Compliant	

ULTRAFILTRATION UFM MEMBRANES					
REF.	OLD REF.	MODEL	NSF/ANSI	DM174-2004	
MCUE4040-PF (*)	DD130	UE4040-PF	-	-	

(*) not available in stock.

CSM 4" Membranes



Ref. MCRE4021-BLN

RE4021-BLN

Low pressure grade RO element for brackish water

CSM

SPECIFICATIONS:

General Features	Permeate flow rate:	1,050 GPD (4.0 m ³ /day)
	Nominal salt rejection:	99.2%
	Effective membrane area:	35 ft ² (3.3 m ²)

- The stated product performance is based on data taken after 30 minutes of operation at the following test conditions:
 - 1,500 mg/L NaCl solution at 150 psig (1.0 MPa) applied pressure
 - 15% recovery
 - 77 °F (25 °C)
 - pH 6.5–7.0
- Minimum salt rejection is 99.0%.
- Permeate flow rate for each element may vary but will be no more than 15%.
- All elements are vacuum sealed in a polyethylene bag containing 1.0% SBS (sodium bisulfite) solution and individually packaged in a cardboard box.

Membrane type:	Thin-Film Composite
Membrane material:	Polyamide (PA)
Element configuration:	Spiral-Wound, FRP Wrapping

Dimensions

Model Name	A	B	C	D	E	Part Number	
						Inter-connector	Brine Seal
RE4021-BLN	21.0 inch (534 mm)	4.0 inch (102 mm)	0.75 inch (19.1 mm)	1.05 inch (26.7 mm)	1.05 inch (26.7 mm)	DD004 (*)	DD003 (*)

(*) see 05-03-99-EN data sheet.



- Each membrane element supplied with one brine seal, one interconnector (coupler) and four o-rings.
- All RE4021 elements fit nominal 4.0 inch (102 mm) I.D. pressure vessels.

The information provided in this document is solely for informative purposes. It is the user's responsibility to ensure the appropriate usage of this product. Woongjin Chemical assumes no obligation, liability or damages incurred for the misuse of the product or for the information provided in this document. This document does not express or implies any warranty as to the merchantability or fitness of the product.



RE402 I-BLN

Low pressure grade RO element for brackish water

CSM[®]

APPLICATION DATA:

Operating Limits

· Max. Pressure Drop / Element	15 psi (0.1 MPa)
· Max. Pressure Drop / 240" Vessel	60 psi (0.41 Mpa)
· Max. Operating Pressure	600 psi (4.14 MPa)
· Max. Feed Flow Rate	13 gpm (2.95 m ³ /hr)
· Min. Concentrate Flow Rate	3 gpm (0.68 m ³ /hr)
· Max. Operating Temperature	113 °F (45 °C)
· Operating pH Range	2.0–11.0
· CIP pH Range	1.0–13.0
· Max. Turbidity	1.0 NTU
· Max. SDI (15 min)	5.0
· Max. Chlorine Concentration	< 0.1 mg/L

Design Guidelines for Various Water Sources

· Wastewater Conventional (SDI < 5)	8–12 gfd
· Wastewater Pretreated by UF/MF (SDI < 3)	10–14 gfd
· Seawater, Open Intake (SDI < 5)	7–10 gfd
· Seawater, Beach Well (SDI < 3)	8–12 gfd
· Surface Water (SDI < 5)	12–16 gfd
· Surface Water (SDI < 3)	13–17 gfd
· Well water (SDI < 3)	13–17 gfd
· RO permeate (SDI < 1)	21–30 gfd

Saturation Limits (Using Antiscalants)[†]

· Langelier Saturation Index (LSI)	<+ 1.5
· Stiff and Davis Saturation Index (SDSI)	<+0.5
· CaSO ₄	230% saturation
· SrSO ₄	800% saturation
· BaSO ₄	6,000% saturation
· SiO ₂	100% saturation

[†]The above saturation limits are typically accepted by proprietary antiscalant manufacturers. It is the user's responsibility to ensure proper chemical(s) and concentration are dosed ahead of the membrane system to prevent scale formation anywhere within the membrane system. Membrane elements fouled or damaged due to scale formation are not covered by the limited warranty.

GENERAL HANDLING PROCEDURES

- Elements contained in the boxes must be kept dry at room temperature (7–32°C; 40–95°F) and should not be stored in direct sunlight. If the polyethylene bag is damaged, a new preservative solution (sodium bisulfite) must be added and air-tight sealed to prevent drying and biological growth.
- Permeate from the first hour of operation should be discarded to flush out the preservative solution.
- Elements should be immersed in a preservative solution during storage, shipping and system shutdowns to prevent biological growth and freezing. The standard storage solution contains 1% by weight sodium bisulfite or sodium metabisulfite (food grade). For short term storage (i.e. one week or less) 1% by weight sodium metabisulfite solution is adequate for preventing biological growth.
- Keep elements moist at all times after initial wetting.
- Avoid excessive pressure and flow spikes.
- Only use chemicals compatible with the membrane elements and components. Use of such chemicals may void the element limited warranty.
- Permeate pressure must always be equal or less than the feed/concentrate pressure. Damage caused by permeate back pressure voids the element limited warranty.



Ref. MCRE4021-BLF

RE4021-BLF

Ultra-low pressure RO element for low TDS water

CSM

SPECIFICATIONS:

General Features	Permeate flow rate:	1,050 GPD (4.0 m ³ /day)
	Stabilized salt rejection:	99.2%
	Effective membrane area:	35 ft ² (3.3 m ²)

- The stated product performance is based on data taken after 30 minutes of operation at the following test conditions:
 - 500 mg/L NaCl solution at 100 psig (0.7 MPa) applied pressure
 - 8% recovery
 - 77 °F (25 °C)
 - pH 6.5–7.0
- Minimum salt rejection is 99.0%.
- Permeate flow rate for each element may vary but will be no more than 15%.
- All elements are vacuum sealed in a polyethylene bag containing 1.0% SBS (sodium bisulfite) solution and individually packaged in a cardboard box.

Membrane type:	Thin-Film Composite
Membrane material:	Polyamide (PA)
Element configuration:	Spiral-Wound, FRP Wrapping

Dimensions

Model Name	A	B	C	D	E	Part Number	
						Inter-connector	Brine Seal
RE4021-BLF	21.0 inch (534 mm)	4.0 inch (102 mm)	0.75 inch (19.1 mm)	1.05 inch (26.7 mm)	1.05 inch (26.7 mm)	DD004 (*)	DD003 (*)

(*) see 05-03-99-EN data sheet.



- Each membrane element supplied with one brine seal, one interconnector (coupler) and four o-rings.
- All RE4021 elements fit nominal 4.0 inch (102 mm) I.D. pressure vessels.

The information provided in this document is solely for informative purposes. It is the user's responsibility to ensure the appropriate usage of this product. Woongjin Chemical assumes no obligation, liability or damages incurred for the misuse of the product or for the information provided in this document. This document does not express or imply any warranty as to the merchantability or fitness of the product.



RE402 I-BLF

Ultra-low pressure RO element for low TDS water

APPLICATION DATA:

Operating Limits

· Max. Pressure Drop / Element	15 psi (0.1 MPa)
· Max. Pressure Drop / 240" Vessel	60 psi (0.41 Mpa)
· Max. Operating Pressure	600 psi (4.14 MPa)
· Max. Feed Flow Rate	13 gpm (2.95 m ³ /hr)
· Min. Concentrate Flow Rate	3 gpm (0.68 m ³ /hr)
· Max. Operating Temperature	113 °F (45 °C)
· Operating pH Range	2.0–11.0
· CIP pH Range	1.0–13.0
· Max. Turbidity	1.0 NTU
· Max. SDI (15 min)	5.0
· Max. Chlorine Concentration	< 0.1 mg/L

Design Guidelines for Various Water Sources

· Wastewater Conventional (SDI < 5)	8–12 gfd
· Wastewater Pretreated by UF/MF (SDI < 3)	10–14 gfd
· Seawater, Open Intake (SDI < 5)	7–10 gfd
· Seawater, Beach Well (SDI < 3)	8–12 gfd
· Surface Water (SDI < 5)	12–16 gfd
· Surface Water (SDI < 3)	13–17 gfd
· Well water (SDI < 3)	13–17 gfd
· RO permeate (SDI < 1)	21–30 gfd

Saturation Limits (Using Antiscalants)[†]

· Langelier Saturation Index (LSI)	<+1.5
· Stiff and Davis Saturation Index (SDSI)	<+0.5
· CaSO ₄	230% saturation
· SrSO ₄	800% saturation
· BaSO ₄	6,000% saturation
· SiO ₂	100% saturation

[†]The above saturation limits are typically accepted by proprietary antiscalant manufacturers. It is the user's responsibility to ensure proper chemical(s) and concentration are dosed ahead of the membrane system to prevent scale formation anywhere within the membrane system. Membrane elements fouled or damaged due to scale formation are not covered by the limited warranty.

GENERAL HANDLING PROCEDURES

- Elements contained in the boxes must be kept dry at room temperature (7–32°C; 40–95°F) and should not be stored in direct sunlight. If the polyethylene bag is damaged, a new preservative solution (sodium bisulfite) must be added and air-tight sealed to prevent drying and biological growth.
- Permeate from the first hour of operation should be discarded to flush out the preservative solution.
- Elements should be immersed in a preservative solution during storage, shipping and system shutdowns to prevent biological growth and freezing. The standard storage solution contains 1% by weight sodium bisulfite or sodium metabisulfite (food grade). For short term storage (i.e. one week or less) 1% by weight sodium metabisulfite solution is adequate for preventing biological growth.
- Keep elements moist at all times after initial wetting.
- Avoid excessive pressure and flow spikes.
- Only use chemicals compatible with the membrane elements and components. Use of such chemicals may void the element limited warranty.
- Permeate pressure must always be equal or less than the feed/concentrate pressure. Damage caused by permeate back pressure voids the element limited warranty.

CSM 4" Membranes



Ref. MCRE4040-BLN

RE4040-BLN

Low pressure grade RO element with extended area for brackish water

CSM[®]

SPECIFICATIONS:

General Features	Permeate flow rate:	2,600 GPD (9.8 m ³ /day)
	Nominal salt rejection:	99.2%
	Effective membrane area:	85 ft ² (7.9 m ²)

1. The stated product performance is based on data taken after 30 minutes of operation at the following test conditions:

- 1,500 mg/L NaCl solution at 150 psig (1.0 MPa) applied pressure
- 15% recovery
- 77 °F (25 °C)
- pH 6.5–7.0

2. Minimum salt rejection is 99.0%.

3. Permeate flow rate for each element may vary but will be no more than 10%.

4. All elements are vacuum sealed in a polyethylene bag containing 1.0% SBS (sodium bisulfite) solution and individually packaged in a cardboard box.

Membrane type:	Thin-Film Composite
Membrane material:	Polyamide (PA)
Element configuration:	Spiral-Wound, FRP Wrapping

Dimensions

Model Name	A	B	C	D	E
RE4040-BLN	40.0 inch (1,016 mm)	4.0 inch (102 mm)	0.75 inch (19.1 mm)	1.61 inch (41 mm)	1.61 inch (41 mm)

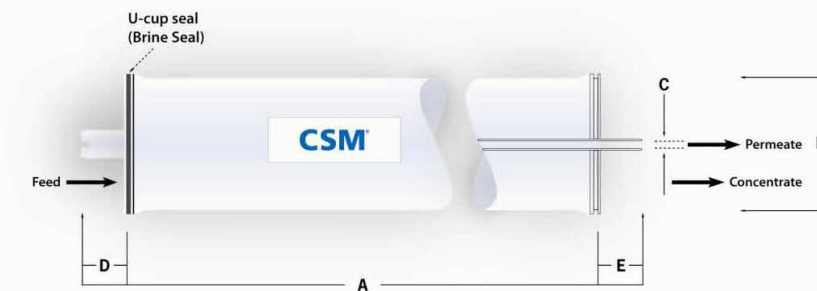

1. Each membrane element supplied with one brine seal, one interconnector (coupler) and four o-rings.
2. All RE4040 elements fit nominal 4.0 inch (102 mm) I.D. pressure vessels.

The information provided in this document is solely for informative purposes. It is the user's responsibility to ensure the appropriate usage of this product. Woongin Chemical assumes no obligation, liability or damages incurred for the misuse of the product or for the information provided in this document. This document does not express or imply any warranty as to the merchantability or fitness of the product.



This product is certified by NSF to NSF/ANSI standard 61



RE4040-BLN

Low pressure grade RO element with extended area for brackish water

CSM[®]

APPLICATION DATA:

Operating Limits

· Max. Pressure Drop / Element	15 psi (0.1 MPa)
· Max. Pressure Drop / 240" Vessel	60 psi (0.41 Mpa)
· Max. Operating Pressure	600 psi (4.14 MPa)
· Max. Feed Flow Rate	18 gpm (4.09 m ³ /hr)
· Min. Concentrate Flow Rate	4 gpm (0.91 m ³ /hr)
· Max. Operating Temperature	113 °F (45 °C)
· Operating pH Range	2.0–11.0
· CIP pH Range	1.0–13.0
· Max. Turbidity	1.0 NTU
· Max. SDI (15 min)	5.0
· Max. Chlorine Concentration	< 0.1 mg/L

Design Guidelines for Various Water Sources

· Wastewater Conventional (SDI < 5)	8–12 gfd
· Wastewater Pretreated by UF/MF (SDI < 3)	10–14 gfd
· Seawater, Open Intake (SDI < 5)	7–10 gfd
· Seawater, Beach Well (SDI < 3)	8–12 gfd
· Surface Water (SDI < 5)	12–16 gfd
· Surface Water (SDI < 3)	13–17 gfd
· Well water (SDI < 3)	13–17 gfd
· RO permeate (SDI < 1)	21–30 gfd

Saturation Limits (Using Antiscalants)[†]

· Langelier Saturation Index (LSI)	<+1.5
· Stiff and Davis Saturation Index (SDSI)	<+0.5
· CaSO ₄	230% saturation
· SrSO ₄	800% saturation
· BaSO ₄	6,000% saturation
· SiO ₂	100% saturation

[†]The above saturation limits are typically accepted by proprietary antiscalant manufacturers. It is the user's responsibility to ensure proper chemical(s) and concentration are dosed ahead of the membrane system to prevent scale formation anywhere within the membrane system. Membrane elements fouled or damaged due to scale formation are not covered by the limited warranty.

GENERAL HANDLING PROCEDURES

- Elements contained in the boxes must be kept dry at room temperature (7–32°C; 40–95°F) and should not be stored in direct sunlight. If the polyethylene bag is damaged, a new preservative solution (sodium bisulfite) must be added and air-tight sealed to prevent drying and biological growth.
- Permeate from the first hour of operation should be discarded to flush out the preservative solution.
- Elements should be immersed in a preservative solution during storage, shipping and system shutdowns to prevent biological growth and freezing. The standard storage solution contains 1% by weight sodium bisulfite or sodium metabisulfite (food grade). For short term storage (i.e. one week or less) 1% by weight sodium metabisulfite solution is adequate for preventing biological growth.
- Keep elements moist at all times after initial wetting.
- Avoid excessive pressure and flow spikes.
- Only use chemicals compatible with the membrane elements and components. Use of such chemicals may void the element limited warranty.
- Permeate pressure must always be equal or less than the feed/concentrate pressure. Damage caused by permeate back pressure voids the element limited warranty.

CSM 4" Membranes



Ref. MCRE4040-BLF

RE4040-BLF

Ultra-low pressure grade RO element for low TDS water

CSM

SPECIFICATIONS:

General Features	Permeate flow rate:	2,500 GPD (9.5 m ³ /day)
	Nominal salt rejection:	99.2%
	Effective membrane area:	85 ft ² (7.9 m ²)

- The stated product performance is based on data taken after 30 minutes of operation at the following test conditions:
 - 500 mg/L NaCl solution at 100 psig (0.7 MPa) applied pressure
 - 15% recovery
 - 77 °F (25 °C)
 - pH 6.5–7.0
- Minimum salt rejection is 99.0%.
- Permeate flow rate for each element may vary but will be no more than 10%.
- All elements are vacuum sealed in a polyethylene bag containing 1.0% SBS (sodium bisulfite) solution and individually packaged in a cardboard box.

Membrane type:	Thin-Film Composite
Membrane material:	Polyamide (PA)
Element configuration:	Spiral-Wound, FRP Wrapping

Dimensions

Model Name	A	B	C	D	E
RE4040-BLF	40.0 inch (1,016 mm)	4.0 inch (102 mm)	0.75 inch (19.1 mm)	1.06 inch (27 mm)	1.06 inch (27 mm)



- Each membrane element supplied with one brine seal, one interconnector (coupler) and four o-rings.
- All RE4040 elements fit nominal 4.0 inch (102 mm) I.D. pressure vessels.

The information provided in this document is solely for informative purposes. It is the user's responsibility to ensure the appropriate usage of this product. Woongjin Chemical assumes no obligation, liability or damages incurred for the misuse of the product or for the information provided in this document. This document does not express or implies any warranty as to the merchantability or fitness of the product.



This product is certified by NSF to NSF/ANSI standard 61



RE4040-BLF

Ultra-low pressure grade RO element for low TDS water

CSM[®]

APPLICATION DATA:

Operating Limits

· Max. Pressure Drop / Element	15 psi (0.1 MPa)
· Max. Pressure Drop / 240" Vessel	60 psi (0.41 MPa)
· Max. Operating Pressure	600 psi (4.14 MPa)
· Max. Feed Flow Rate	18 gpm (4.09 m ³ /hr)
· Min. Concentrate Flow Rate	4 gpm (0.91 m ³ /hr)
· Max. Operating Temperature	113 °F (45 °C)
· Operating pH Range	2.0–11.0
· CIP pH Range	1.0–13.0
· Max. Turbidity	1.0 NTU
· Max. SDI (15 min)	5.0
· Max. Chlorine Concentration	< 0.1 mg/L

Design Guidelines for Various Water Sources

· Wastewater Conventional (SDI < 5)	8–12 gfd
· Wastewater Pretreated by UF/MF (SDI < 3)	10–14 gfd
· Seawater, Open Intake (SDI < 5)	7–10 gfd
· Seawater, Beach Well (SDI < 3)	8–12 gfd
· Surface Water (SDI < 5)	12–16 gfd
· Surface Water (SDI < 3)	13–17 gfd
· Well water (SDI < 3)	13–17 gfd
· RO permeate (SDI < 1)	21–30 gfd

Saturation Limits (Using Antiscalants)[†]

· Langlier Saturation Index (LSI)	<+1.5
· Stiff and Davis Saturation Index (SDSI)	<+0.5
· CaSO ₄	230% saturation
· SrSO ₄	800% saturation
· BaSO ₄	6,000% saturation
· SiO ₂	100% saturation

[†]The above saturation limits are typically accepted by proprietary antiscalant manufacturers. It is the user's responsibility to ensure proper chemical(s) and concentration are dosed ahead of the membrane system to prevent scale formation anywhere within the membrane system. Membrane elements fouled or damaged due to scale formation are not covered by the limited warranty.

GENERAL HANDLING PROCEDURES

- Elements contained in the boxes must be kept dry at room temperature (7–32°C; 40–95°F) and should not be stored in direct sunlight. If the polyethylene bag is damaged, a new preservative solution (sodium bisulfite) must be added and air-tight sealed to prevent drying and biological growth.
- Permeate from the first hour of operation should be discarded to flush out the preservative solution.
- Elements should be immersed in a preservative solution during storage, shipping and system shutdowns to prevent biological growth and freezing. The standard storage solution contains 1% by weight sodium bisulfite or sodium metabisulfite (food grade). For short term storage (i.e. one week or less) 1% by weight sodium metabisulfite solution is adequate for preventing biological growth.
- Keep elements moist at all times after initial wetting.
- Avoid excessive pressure and flow spikes.
- Only use chemicals compatible with the membrane elements and components. Use of such chemicals may void the element limited warranty.
- Permeate pressure must always be equal or less than the feed/concentrate pressure. Damage caused by permeate back pressure voids the element limited warranty.

CSM 4" Membranes



Ref. MCRE4040-BLR

RE4040-BLR

Low pressure grade RO element with high salt rejection for brackish water

CSM

SPECIFICATIONS:

General Features	Permeate flow rate:	1,900 GPD (7.2 m ³ /day)
	Nominal salt rejection:	99.6%
	Effective membrane area:	85 ft ² (7.9 m ²)

- The stated product performance is based on data taken after 30 minutes of operation at the following test conditions:
 - 1,500 mg/L NaCl solution at 150 psig (1.0 MPa) applied pressure
 - 15% recovery
 - 77 °F (25 °C)
 - pH 6.5–7.0
- Minimum salt rejection is 99.5%.
- Permeate flow rate for each element may vary but will be no more than 10%.
- All elements are vacuum sealed in a polyethylene bag containing 1.0% SBS (sodium bisulfite) solution and individually packaged in a cardboard box.

Membrane type:	Thin-Film Composite
Membrane material:	Polyamide (PA)
Element configuration:	Spiral-Wound, FRP Wrapping

Dimensions

Model Name	A	B	C	D	E
RE4040-BLR	40.0 inch (1,016 mm)	4.0 inch (102 mm)	0.75 inch (19.1 mm)	1.61 inch (41 mm)	1.61 inch (41 mm)



- Each membrane element supplied with one brine seal, one interconnector (coupler) and four o-rings.
- All RE4040 elements fit nominal 4.0 inch (102 mm) I.D. pressure vessels.

The information provided in this document is solely for informative purposes. It is the user's responsibility to ensure the appropriate usage of this product. Woongjin Chemical assumes no obligation, liability or damages incurred for the misuse of the product or for the information provided in this document. This document does not express or imply any warranty as to the merchantability or fitness of the product.



This product is certified by NSF to NSF/ANSI standard 61



RE4040-BLR

Low pressure grade RO element with high salt rejection for brackish water

APPLICATION DATA:

Operating Limits

· Max. Pressure Drop / Element	15 psi (0.1 MPa)
· Max. Pressure Drop / 240" Vessel	60 psi (0.41 Mpa)
· Max. Operating Pressure	600 psi (4.14 MPa)
· Max. Feed Flow Rate	18 gpm (4.09 m ³ /hr)
· Min. Concentrate Flow Rate	4 gpm (0.91 m ³ /hr)
· Max. Operating Temperature	113 °F (45 °C)
· Operating pH Range	2.0–11.0
· CIP pH Range	1.0–13.0
· Max. Turbidity	1.0 NTU
· Max. SDI (15 min)	5.0
· Max. Chlorine Concentration	< 0.1 mg/L

Design Guidelines for Various Water Sources

· Wastewater Conventional (SDI < 5)	8–12 gfd
· Wastewater Pretreated by UF/MF (SDI < 3)	10–14 gfd
· Seawater, Open Intake (SDI < 5)	7–10 gfd
· Seawater, Beach Well (SDI < 3)	8–12 gfd
· Surface Water (SDI < 5)	12–16 gfd
· Surface Water (SDI < 3)	13–17 gfd
· Well water (SDI < 3)	13–17 gfd
· RO permeate (SDI < 1)	21–30 gfd

Saturation Limits (Using Antiscalants)[†]

· Langelier Saturation Index (LSI)	<+ 1.5
· Stiff and Davis Saturation Index (SDSI)	<+0.5
· CaSO ₄	230% saturation
· SrSO ₄	800% saturation
· BaSO ₄	6,000% saturation
· SiO ₂	100% saturation

[†]The above saturation limits are typically accepted by proprietary antiscalant manufacturers. It is the user's responsibility to ensure proper chemical(s) and concentration are dosed ahead of the membrane system to prevent scale formation anywhere within the membrane system. Membrane elements fouled or damaged due to scale formation are not covered by the limited warranty.

GENERAL HANDLING PROCEDURES

- Elements contained in the boxes must be kept dry at room temperature (7–32°C; 40–95°F) and should not be stored in direct sunlight. If the polyethylene bag is damaged, a new preservative solution (sodium bisulfite) must be added and air-tight sealed to prevent drying and biological growth.
- Permeate from the first hour of operation should be discarded to flush out the preservative solution.
- Elements should be immersed in a preservative solution during storage, shipping and system shutdowns to prevent biological growth and freezing. The standard storage solution contains 1% by weight sodium bisulfite or sodium metabisulfite (food grade). For short term storage (i.e. one week or less) 1% by weight sodium metabisulfite solution is adequate for preventing biological growth.
- Keep elements moist at all times after initial wetting.
- Avoid excessive pressure and flow spikes.
- Only use chemicals compatible with the membrane elements and components. Use of such chemicals may void the element limited warranty.
- Permeate pressure must always be equal or less than the feed/concentrate pressure. Damage caused by permeate back pressure voids the element limited warranty.

TORAY 4" Membranes



Ref. MTMG10D

TORAY
Innovation by Chemistry

Ultra low pressure BWRO, enhanced chemical tolerance

TMG (D)

Type	Diameter Inch	Membrane Area ft ² (m ²)	Salt Rejection %	Product Flow Rate gpd(m ³ / d)	Feed Spacer Thickness mil
TMG10D	4"	87(8)	99.7	2,850(10.8)	34

1. Membrane Type		Cross Linked Fully Aromatic Polyamide Composite
2. Test Conditions	Feed Water Pressure Feed Water Temperature Feed Water Concentration Recovery Rate Feed Water pH	150 psi(1.03MPa) 77° F(25°C) 2000 mg/l Nacl 15% 7
3. Minimum Salt Rejection		99.5%
4. Minimum Product Flow Rate		2,400gpd(9.1m ³ /d)

Dimensions

All dimensions shown in Inches (millimeter).

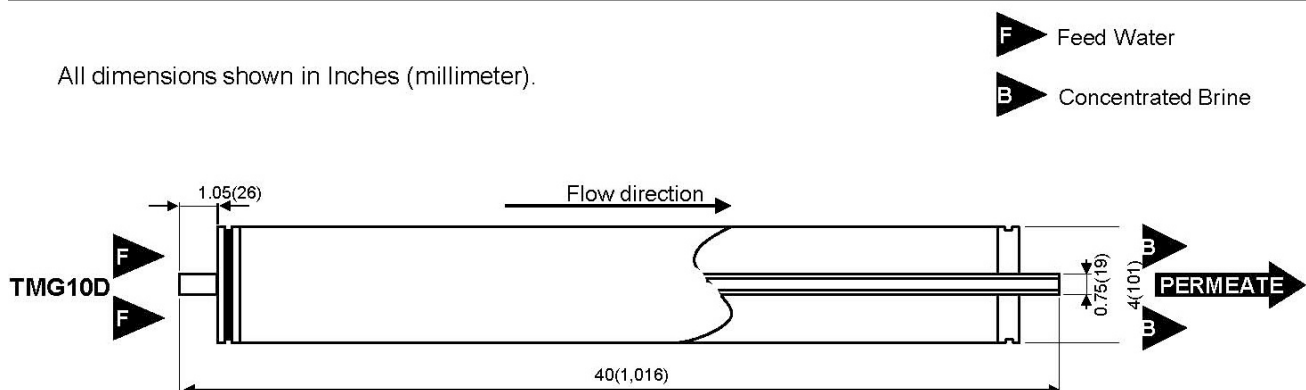



Operating Limits

Maximum Operating Pressure	_____	365psi (2.5 MPa)
Maximum Feed Water Temperature	_____	113° F (45°C)
Maximum Feed Water SDI15	_____	5
Feed Water Chlorine Concentration	_____ ^{*See below 3 of Operating Information}	< 0.1ppm
Feed Water pH Range, Continuous Operation	_____	2-11
Feed Water pH Range, Chemical Cleaning	_____	1-13
Maximum Pressure Drop per Element	_____	15psi (0.10 MPa)
Maximum Pressure Drop per Vessel	_____	50psi (0.34 MPa)

Operating Information

1. For the recommended design range, please consult the latest Toray technical bulletin, design guide lines, computer design program, and/ or call an application specialist. If the operating limits given in this Product Information Bulletin are not strictly followed, the Limited Warranty will be null and void.
2. All elements are wet tested, treated with a 1% by weight percent sodium bisulfite storage solution, and then vacuum packed in oxygen barrier bags, or treated with tested feed water solution, and then vacuum packed in oxygen barrier bags with deoxidant inside. To prevent biological growth during short term storage, shipment, or system shutdown, it is recommended that Toray elements be immersed in a protective solution containing 500 - 1,000 ppm of sodium bisulfite (food grade) dissolved in permeate.
3. The presence of free chlorine and other oxidizing agents under certain conditions, such as heavy metals which acts as oxidation catalyst in the feed water will cause unexpected oxidation of the membrane. Since oxidation damage is not covered under warranty, it is strongly recommended to remove these oxidizing agents contained in feed water before operating RO system.
4. Permeate from the first hour of operation shall be discarded.
5. The customer is fully responsible for the effects of chemicals that are incompatible with the elements. Their use will void the element Limited Warranty.

Notice

1. Toray accepts no responsibility for results obtained by the application of this information or the safety or suitability of Toray's products, either alone or in combination with other products. Users are advised to make their own tests to determine the safety and suitability of each product combination for their own purposes.
2. All data may change without prior notice, due to technical modifications or production changes.

CSM 4" Membranes



Ref. MCRE4021-BE

RE4021-BE

High productivity RO element for brackish water

CSM

SPECIFICATIONS:

General Features	Permeate flow rate:	1,050 GPD (4.0 m ³ /day)
	Nominal salt rejection:	99.7%
	Effective membrane area:	35 ft ² (3.3 m ²)

- The stated product performance is based on data taken after 30 minutes of operation at the following test conditions:
 - 2,000 mg/L NaCl solution at 225 psig (1.5 MPa) applied pressure
 - 8% recovery
 - 77 °F (25 °C)
 - pH 6.5–7.0
- Minimum salt rejection is 99.4%.
- Permeate flow rate for each element may vary but will be no more than 15%.
- All elements are vacuum sealed in a polyethylene bag containing 1.0% SBS (sodium bisulfite) solution and individually packaged in a cardboard box.

Membrane type:	Thin-Film Composite
Membrane material:	Polyamide (PA)
Element configuration:	Spiral-Wound, FRP Wrapping

Dimensions

Model Name	A	B	C	D	E	Part Number	
						Inter-connector	Brine Seal
RE4021-BE	21.0 inch (534 mm)	4.0 inch (102 mm)	0.75 inch (19.1 mm)	1.05 inch (26.7 mm)	1.05 inch (26.7 mm)	DD004 (*)	DD003 (*)

(*) see 05-03-99-EN data sheet.



- Each membrane element supplied with one brine seal, one interconnector (coupler) and four o-rings.
- All RE4021 elements fit nominal 4.0 inch (102 mm) I.D. pressure vessels.

The information provided in this document is solely for informative purposes. It is the user's responsibility to ensure the appropriate usage of this product. Woongjin Chemical assumes no obligation, liability or damages incurred for the misuse of the product or for the information provided in this document. This document does not express or implies any warranty as to the merchantability or fitness of the product.



RE402 I-BE

High productivity RO element for brackish water

CSM[®]

APPLICATION DATA:

Operating Limits

· Max. Pressure Drop / Element	15 psi (0.1 MPa)
· Max. Pressure Drop / 240" Vessel	60 psi (0.41 MPa)
· Max. Operating Pressure	600 psi (4.14 MPa)
· Max. Feed Flow Rate	13 gpm (2.95 m ³ /hr)
· Min. Concentrate Flow Rate	3 gpm (0.68 m ³ /hr)
· Max. Operating Temperature	113 °F (45 °C)
· Operating pH Range	2.0–11.0
· CIP pH Range	1.0–13.0
· Max. Turbidity	1.0 NTU
· Max. SDI (15 min)	5.0
· Max. Chlorine Concentration	< 0.1 mg/L

Design Guidelines for Various Water Sources

· Wastewater Conventional (SDI < 5)	8–12 gfd
· Wastewater Pretreated by UF/MF (SDI < 3)	10–14 gfd
· Seawater, Open Intake (SDI < 5)	7–10 gfd
· Seawater, Beach Well (SDI < 3)	8–12 gfd
· Surface Water (SDI < 5)	12–16 gfd
· Surface Water (SDI < 3)	13–17 gfd
· Well water (SDI < 3)	13–17 gfd
· RO permeate (SDI < 1)	21–30 gfd

Saturation Limits (Using Antiscalants)[†]

· Langelier Saturation Index (LSI)	<+1.5
· Stiff and Davis Saturation Index (SDSI)	<+0.5
· CaSO ₄	230% saturation
· SrSO ₄	800% saturation
· BaSO ₄	6,000% saturation
· SiO ₂	100% saturation

[†]The above saturation limits are typically accepted by proprietary antiscalant manufacturers. It is the user's responsibility to ensure proper chemical(s) and concentration are dosed ahead of the membrane system to prevent scale formation anywhere within the membrane system. Membrane elements fouled or damaged due to scale formation are not covered by the limited warranty.

GENERAL HANDLING PROCEDURES

- Elements contained in the boxes must be kept dry at room temperature (7–32°C; 40–95°F) and should not be stored in direct sunlight. If the polyethylene bag is damaged, a new preservative solution (sodium bisulfite) must be added and air-tight sealed to prevent drying and biological growth.
- Permeate from the first hour of operation should be discarded to flush out the preservative solution.
- Elements should be immersed in a preservative solution during storage, shipping and system shutdowns to prevent biological growth and freezing. The standard storage solution contains 1% by weight sodium bisulfite or sodium metabisulfite (food grade). For short term storage (i.e. one week or less) 1% by weight sodium metabisulfite solution is adequate for preventing biological growth.
- Keep elements moist at all times after initial wetting.
- Avoid excessive pressure and flow spikes.
- Only use chemicals compatible with the membrane elements and components. Use of such chemicals may void the element limited warranty.
- Permeate pressure must always be equal or less than the feed/concentrate pressure. Damage caused by permeate back pressure voids the element limited warranty.



Ref. MCRE4040-BE

RE4040-BE

High productivity RO element with extended area for brackish water

CSM[®]

SPECIFICATIONS:

General Features	Permeate flow rate:	2,400 GPD (9.1 m ³ /day)
	Nominal salt rejection:	99.7%
	Effective membrane area:	85 ft ² (7.9 m ²)

1. The stated product performance is based on data taken after 30 minutes of operation at the following test conditions:

- 2,000 mg/L NaCl solution at 225 psig (1.5 MPa) applied pressure
- 15% recovery
- 77 °F (25 °C)
- pH 6.5–7.0

2. Minimum salt rejection is 99.4%.

3. Permeate flow rate for each element may vary but will be no more than 10%.

4. All elements are vacuum sealed in a polyethylene bag containing 1.0% SBS (sodium bisulfite) solution and individually packaged in a cardboard box.

Membrane type:	Thin-Film Composite
Membrane material:	Polyamide (PA)
Element configuration:	Spiral-Wound, FRP Wrapping

Dimensions

Model Name	A	B	C	D	E
RE4040-BE	40.0 inch (1,016 mm)	4.0 inch (102 mm)	0.75 inch (19.1 mm)	1.61 inch (41 mm)	1.61 inch (41 mm)



1. Each membrane element supplied with one brine seal, one interconnector (coupler) and four o-rings.
2. All RE4040 elements fit nominal 4.0 inch (102 mm) I.D. pressure vessels.

The information provided in this document is solely for informative purposes. It is the user's responsibility to ensure the appropriate usage of this product. Woongjin Chemical assumes no obligation, liability or damages incurred for the misuse of the product or for the information provided in this document. This document does not express or implies any warranty as to the merchantability or fitness of the product.



RE4040-BE

High productivity RO element with extended area for brackish water

CSM[®]

APPLICATION DATA:

Operating Limits

· Max. Pressure Drop / Element	15 psi (0.1 MPa)
· Max. Pressure Drop / 240" Vessel	60 psi (0.41 MPa)
· Max. Operating Pressure	600 psi (4.14 MPa)
· Max. Feed Flow Rate	18 gpm (4.09 m ³ /hr)
· Min. Concentrate Flow Rate	4 gpm (0.91 m ³ /hr)
· Max. Operating Temperature	113 °F (45 °C)
· Operating pH Range	2.0–11.0
· CIP pH Range	1.0–13.0
· Max. Turbidity	1.0 NTU
· Max. SDI (15 min)	5.0
· Max. Chlorine Concentration	< 0.1 mg/L

Design Guidelines for Various Water Sources

· Wastewater Conventional (SDI < 5)	8–12 gfd
· Wastewater Pretreated by UF/MF (SDI < 3)	10–14 gfd
· Seawater, Open Intake (SDI < 5)	7–10 gfd
· Seawater, Beach Well (SDI < 3)	8–12 gfd
· Surface Water (SDI < 5)	12–16 gfd
· Surface Water (SDI < 3)	13–17 gfd
· Well water (SDI < 3)	13–17 gfd
· RO permeate (SDI < 1)	21–30 gfd

Saturation Limits (Using Antiscalants)[†]

· Langelier Saturation Index (LSI)	<+ 1.5
· Stiff and Davis Saturation Index (SDSI)	<+0.5
· CaSO ₄	230% saturation
· SrSO ₄	800% saturation
· BaSO ₄	6,000% saturation
· SiO ₂	100% saturation

[†]The above saturation limits are typically accepted by proprietary antiscalant manufacturers. It is the user's responsibility to ensure proper chemical(s) and concentration are dosed ahead of the membrane system to prevent scale formation anywhere within the membrane system. Membrane elements fouled or damaged due to scale formation are not covered by the limited warranty.

GENERAL HANDLING PROCEDURES

- Elements contained in the boxes must be kept dry at room temperature (7–32°C; 40–95°F) and should not be stored in direct sunlight. If the polyethylene bag is damaged, a new preservative solution (sodium bisulfite) must be added and air-tight sealed to prevent drying and biological growth.
- Permeate from the first hour of operation should be discarded to flush out the preservative solution.
- Elements should be immersed in a preservative solution during storage, shipping and system shutdowns to prevent biological growth and freezing. The standard storage solution contains 1% by weight sodium bisulfite or sodium metabisulfite (food grade). For short term storage (i.e. one week or less) 1% by weight sodium metabisulfite solution is adequate for preventing biological growth.
- Keep elements moist at all times after initial wetting.
- Avoid excessive pressure and flow spikes.
- Only use chemicals compatible with the membrane elements and components. Use of such chemicals may void the element limited warranty.
- Permeate pressure must always be equal or less than the feed/concentrate pressure. Damage caused by permeate back pressure voids the element limited warranty.

TORAY 4" Membranes



Ref. MTM710D

TORAY
Innovation by Chemistry

High rejection BWRO, enhanced chemical tolerance

TM700D

Type	Diameter Inch	Membrane Area ft ² (m ²)	Salt Rejection %	Product Flow Rate gpd(m ³ / d)	Feed Spacer Thickness mil
TM710D	4"	87(8)	99.8	2,600(9.8)	31

1. Membrane Type		Cross Linked Fully Aromatic Polyamide Composite
2. Test Conditions	Feed Water Pressure Feed Water Temperature Feed Water Concentration Recovery Rate Feed Water pH	225 psi(1.55MPa) 77° F(25°C) 2,000 mg/l NaCl 15% 7
3. Minimum Salt Rejection		99.65%
4. Minimum Product Flow Rate		2,150gpd(8.2m ³ /d)

Dimensions

All dimensions shown in Inches (millimeter).

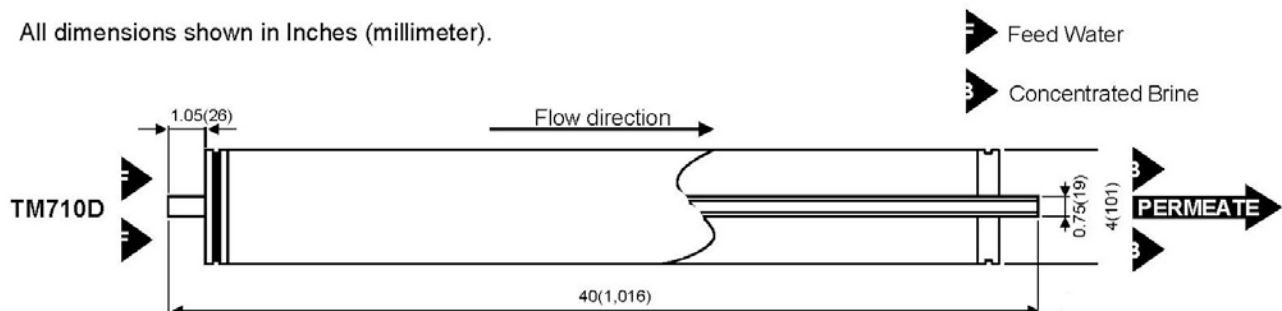



Operating Limits

Maximum Operating Pressure	600psi (4.1 MPa)
Maximum Feed Water Temperature	113° F (45°C)
Maximum Feed Water SDI ₁₅	5
Feed Water Chlorine Concentration <small>*See below 3 of Operating Information</small>	<0.1 ppm
Feed Water pH Range, Continuous Operation	2-11
Feed Water pH Range, Chemical Cleaning	1-13
Maximum Pressure Drop per Element	15 psi (0.10 MPa)
Maximum Pressure Drop per Vessel	50 psi (0.34 MPa)

Operating Information

1. For the recommended design range, please consult the latest Toray technical bulletin, design guide lines, computer design program, and/ or call an application specialist. If the operating limits given in this Product Information Bulletin are not strictly followed, the Limited Warranty will be null and void.
 2. All elements are wet tested, treated with a 1% by weight percent sodium bisulfite storage solution, and then vacuum packed in oxygen barrier bags, or treated with tested feed water solution, and then vacuum packed in oxygen barrier bags with deoxidant inside. To prevent biological growth during short term storage, shipment, or system shutdown, it is recommended that Toray elements be immersed in a protective solution containing 500 - 1,000 ppm of sodium bisulfite (food grade) dissolved in permeate.
 3. The presence of free chlorine and other oxidizing agents under certain conditions, such as heavy metals which acts as oxidation catalyst in the feed water will cause unexpected oxidation of the membrane. It is strongly recommended to remove these oxidizing agents contained in feed water before operating RO system.
 4. Permeate from the first hour of operation shall be discarded.
 5. The customer is fully responsible for the effects of chemicals that are incompatible with the elements. Their use will void the element Limited Warranty.
-

Notice

1. Toray accepts no responsibility for results obtained by the application of this information or the safety or suitability of Toray's products, either alone or in combination with other products. Users are advised to make their own tests to determine the safety and suitability of each product combination for their own purposes.
2. All data may change without prior notice, due to technical modifications or production changes.

CSM 4" Membranes



Ref. MCRE4040-CE

RE4040-CE

Innovative chlorine resistant RO element for prolonged membrane lifetime

CSM[®]

SPECIFICATIONS:

General Features	Permeate flow rate:	1,900 GPD (7.2 m ³ /day)
	Nominal salt rejection:	99.5%
	Effective membrane area:	85ft ² (7.9m ²)

1. The stated product performance is based on data taken after 30 minutes of operation at the following test conditions:

- 2,000 mg/L NaCl solution at 225 psig (1.5 MPa) applied pressure
- 15% recovery
- 77 °F (25 °C)
- pH 6.5–7.0

2. Minimum salt rejection is 99.0%

3. Permeate flow rate for each element may vary but will be no more than 10%.

4. All elements are vacuum sealed in a polyethylene bag containing 1.0% SBS (sodium bisulfite) solution and individually packaged in a cardboard box

Membrane type:	Thin-Film Composite
Membrane material:	Polyamide (PA)
Element configuration:	Spiral-Wound, FRP Wrapping

Dimensions

Model Name	A	B	C	D	E
RE4040-CE	40.0 inch (1,016 mm)	4.0 inch (102 mm)	0.75 inch (19.1 mm)	1.06 inch (27 mm)	1.06 inch (27 mm)



1. Each membrane element supplied with one brine seal, one interconnector (coupler) and four o-rings.
2. All RE4040 elements fit nominal 4.0 inch (102 mm) I.D. pressure vessels.

The information provided in this document is solely for informative purposes. It is the user's responsibility to ensure the appropriate usage of this product. Woongjin Chemical assumes no obligation, liability or damages incurred for the misuse of the product or for the information provided in this document. This document does not express or imply any warranty as to the merchantability or fitness of the product.



RE4040-CE

Innovative chlorine resistant RO element for prolonged membrane lifetime

CSM[®]

APPLICATION DATA:

Operating Limits

• Max. Pressure Drop / Element	15 psi (0.1 MPa)
• Max. Pressure Drop / 240" Vessel	60 psi (0.41 MPa)
• Max. Operating Pressure	600 psi (4.14 MPa)
• Max. Feed Flow Rate	18 gpm (4.09 m ³ /hr)
• Min. Concentrate Flow Rate	4 gpm (0.91 m ³ /hr)
• Max. Operating Temperature	113 °F (45 °C)
• Operating pH Range	2.0–11.0
• CIP pH Range	1.0–13.0
• Max. Turbidity	1.0 NTU
• Max. SDI (15 min)	5.0
• Free Chlorine Tolerance	5,000 ppm hr

Design Guidelines for Various Water Sources

• Wastewater Conventional (SDI < 5)	8–12 gfd
• Wastewater Pretreated by UF/MF (SDI < 3)	10–14 gfd
• Seawater, Open Intake (SDI < 5)	7–10 gfd
• Seawater, Beach Well (SDI < 3)	8–12 gfd
• Surface Water (SDI < 5)	12–16 gfd
• Surface Water (SDI < 3)	13–17 gfd
• Well water (SDI < 3)	13–17 gfd
• RO permeate (SDI < 1)	21–30 gfd

Saturation Limits (Using Antiscalants)[†]

• Langelier Saturation Index (LSI)	<+1.5
• Stiff and Davis Saturation Index (SDSI)	<+0.5
• CaSO ₄	230% saturation
• SrSO ₄	800% saturation
• BaSO ₄	6,000% saturation
• SiO ₂	100% saturation

[†]The above saturation limits are typically accepted by proprietary antiscalant manufacturers. It is the user's responsibility to ensure proper chemical(s) and concentration are dosed ahead of the membrane system to prevent scale formation anywhere within the membrane system. Membrane elements fouled or damaged due to scale formation are not covered by the limited warranty.

GENERAL HANDLING PROCEDURES

- Elements contained in the boxes must be kept dry at room temperature (7–32°C; 40–95°F) and should not be stored in direct sunlight. If the polyethylene bag is damaged, a new preservative solution (sodium bisulfite) must be added and air-tight sealed to prevent drying and biological growth.
- Permeate from the first hour of operation should be discarded to flush out the preservative solution.
- Elements should be immersed in a preservative solution during storage, shipping and system shutdowns to prevent biological growth and freezing. The standard storage solution contains 1% by weight sodium bisulfite or sodium metabisulfite (food grade). For short term storage (i.e. one week or less) 1% by weight sodium metabisulfite solution is adequate for preventing biological growth.
- Avoid excessive pressure and flow spikes.
- Only use chemicals compatible with the membrane elements and components. Use of such chemicals may void the element limited warranty.
- Permeate pressure must always be equal or less than the feed/concentrate pressure. Damage caused by permeate back pressure voids the element limited warranty.
- Keep elements moist at all times after initial wetting.

CSM 4" Membranes



Ref. MCRE4040-FEN

RE4040-FEn

CSM[®]

Fouling resistant RO element with extended area for brackish water and wastewater reuse

SPECIFICATIONS:

General Features	Permeate flow rate:	2,400 GPD (9.1 m ³ /day)
	Nominal salt rejection:	99.7%
	Effective membrane area:	85 ft ² (7.9 m ²)

1. The stated product performance is based on data taken after 30 minutes of operation at the following test conditions:

- 2,000 mg/L NaCl solution at 225 psig (1.5 MPa) applied pressure
- 15% recovery
- 77 °F (25 °C)
- pH 6.5–7.0

2. Minimum salt rejection is 99.5%.

3. Permeate flow rate for each element may vary but will be no more than 10%.

4. All elements are vacuum sealed in a polyethylene bag containing 1.0% SBS (sodium bisulfite) solution and individually packaged in a cardboard box.

Membrane type:	Thin-Film Composite
Membrane material:	Polyamide (PA)
Element configuration:	Spiral-Wound, FRP Wrapping

Dimensions

Model Name	A	B	C	D	E
RE4040-FEn	40.0 inch (1,016 mm)	4.0 inch (102 mm)	0.75 inch (19.1 mm)	1.06 inch (27 mm)	1.06 inch (27 mm)



1. Each membrane element supplied with one brine seal, one interconnector (coupler) and four o-rings.
2. All RE4040 elements fit nominal 4.0 inch (102 mm) I.D. pressure vessels.

The information provided in this document is solely for informative purposes. It is the user's responsibility to ensure the appropriate usage of this product. Woongjin Chemical assumes no obligation, liability or damages incurred for the misuse of the product or for the information provided in this document. This document does not express or imply any warranty as to the merchantability or fitness of the product.



RE4040-FEn

Fouling resistant RO element with extended area for brackish water and wastewater reuse

CSM[®]

APPLICATION DATA:

Operating Limits

· Max. Pressure Drop / Element	15 psi (0.1 MPa)
· Max. Pressure Drop / 240" Vessel	60 psi (0.41 MPa)
· Max. Operating Pressure	600 psi (4.14 MPa)
· Max. Feed Flow Rate	18 gpm (4.09 m ³ /hr)
· Min. Concentrate Flow Rate	4 gpm (0.91 m ³ /hr)
· Max. Operating Temperature	113 °F (45 °C)
· Operating pH Range	2.0–11.0
· CIP pH Range	1.0–13.0
· Max. Turbidity	1.0 NTU
· Max. SDI (15 min)	5.0
· Max. Chlorine Concentration	< 0.1 mg/L

Design Guidelines for Various Water Sources

· Wastewater Conventional (SDI < 5)	8–12 gfd
· Wastewater Pretreated by UF/MF (SDI < 3)	10–14 gfd
· Seawater, Open Intake (SDI < 5)	7–10 gfd
· Seawater, Beach Well (SDI < 3)	8–12 gfd
· Surface Water (SDI < 5)	12–16 gfd
· Surface Water (SDI < 3)	13–17 gfd
· Well water (SDI < 3)	13–17 gfd
· RO permeate (SDI < 1)	21–30 gfd

Saturation Limits (Using Antiscalants)[†]

· Langelier Saturation Index (LSI)	<+1.5
· Stiff and Davis Saturation Index (SDSI)	<+0.5
· CaSO ₄	230% saturation
· SrSO ₄	800% saturation
· BaSO ₄	6,000% saturation
· SiO ₂	100% saturation

[†]The above saturation limits are typically accepted by proprietary antiscalant manufacturers. It is the user's responsibility to ensure proper chemical(s) and concentration are dosed ahead of the membrane system to prevent scale formation anywhere within the membrane system. Membrane elements fouled or damaged due to scale formation are not covered by the limited warranty.

GENERAL HANDLING PROCEDURES

- Elements contained in the boxes must be kept dry at room temperature (7–32°C; 40–95°F) and should not be stored in direct sunlight. If the polyethylene bag is damaged, a new preservative solution (sodium bisulfite) must be added and air-tight sealed to prevent drying and biological growth.
- Permeate from the first hour of operation should be discarded to flush out the preservative solution.
- Elements should be immersed in a preservative solution during storage, shipping and system shutdowns to prevent biological growth and freezing. The standard storage solution contains 1% by weight sodium bisulfite or sodium metabisulfite (food grade). For short term storage (i.e. one week or less) 1% by weight sodium metabisulfite solution is adequate for preventing biological growth.
- Keep elements moist at all times after initial wetting.
- Avoid excessive pressure and flow spikes.
- Only use chemicals compatible with the membrane elements and components. Use of such chemicals may void the element limited warranty.
- Permeate pressure must always be equal or less than the feed/concentrate pressure. Damage caused by permeate back pressure voids the element limited warranty.



Ref. MCRE4040-FL

RE4040-FL

CSM[®]

Low pressure grade fouling resistant RO element for brackish water and wastewater reuse

SPECIFICATIONS:

General Features	Permeate flow rate:	2,400 GPD (9.1 m ³ /day)
	Nominal salt rejection:	99.0%
	Effective membrane area:	85 ft ² (7.9 m ²)

1. The stated product performance is based on data taken after 30 minutes of operation at the following test conditions:

- 1,500 mg/L NaCl solution at 150 psig (1.0 MPa) applied pressure
- 15% recovery
- 77 °F (25 °C)
- pH 6.5–7.0

2. Minimum salt rejection is 98.5%.

3. Permeate flow rate for each element may vary but will be no more than 10%.

4. All elements are vacuum sealed in a polyethylene bag containing 1.0% SBS (sodium bisulfite) solution and individually packaged in a cardboard box.

Membrane type:	Thin-Film Composite
Membrane material:	Polyamide (PA)
Element configuration:	Spiral-Wound, FRP Wrapping

Dimensions

Model Name	A	B	C	D	E
RE4040-CE	40.0 inch (1,016 mm)	4.0 inch (102 mm)	0.75 inch (19.1 mm)	1.06 inch (27 mm)	1.06 inch (27 mm)



1. Each membrane element supplied with one brine seal, one interconnector (coupler) and four o-rings.
2. All RE4040 elements fit nominal 4.0 inch (102 mm) I.D. pressure vessels.

The information provided in this document is solely for informative purposes. It is the user's responsibility to ensure the appropriate usage of this product. Woongjin Chemical assumes no obligation, liability or damages incurred for the misuse of the product or for the information provided in this document. This document does not express or implies any warranty as to the merchantability or fitness of the product.



RE4040-FL

Low pressure grade fouling resistant RO element for brackish water and wastewater reuse

CSM[®]

APPLICATION DATA:

Operating Limits

• Max. Pressure Drop / Element	15 psi (0.1 MPa)
• Max. Pressure Drop / 240" Vessel	60 psi (0.41 MPa)
• Max. Operating Pressure	600 psi (4.14 MPa)
• Max. Feed Flow Rate	18 gpm (4.09 m ³ /hr)
• Min. Concentrate Flow Rate	4 gpm (0.91 m ³ /hr)
• Max. Operating Temperature	113 °F (45 °C)
• Operating pH Range	2.0–11.0
• CIP pH Range	1.0–13.0
• Max. Turbidity	1.0 NTU
• Max. SDI (15 min)	5.0
• Max. Chlorine Concentration	< 0.1 mg/L

Design Guidelines for Various Water Sources

• Wastewater Conventional (SDI < 5)	8–12 gfd
• Wastewater Pretreated by UF/MF (SDI < 3)	10–14 gfd
• Seawater, Open Intake (SDI < 5)	7–10 gfd
• Seawater, Beach Well (SDI < 3)	8–12 gfd
• Surface Water (SDI < 5)	12–16 gfd
• Surface Water (SDI < 3)	13–17 gfd
• Well water (SDI < 3)	13–17 gfd
• RO permeate (SDI < 1)	21–30 gfd

Saturation Limits (Using Antiscalants)[†]

• Langelier Saturation Index (LSI)	<+1.5
• Stiff and Davis Saturation Index (SDSI)	<+0.5
• CaSO ₄	230% saturation
• SrSO ₄	800% saturation
• BaSO ₄	6,000% saturation
• SiO ₂	100% saturation

[†]The above saturation limits are typically accepted by proprietary antiscalant manufacturers. It is the user's responsibility to ensure proper chemical(s) and concentration are dosed ahead of the membrane system to prevent scale formation anywhere within the membrane system. Membrane elements fouled or damaged due to scale formation are not covered by the limited warranty.

GENERAL HANDLING PROCEDURES

- Elements contained in the boxes must be kept dry at room temperature (7–32 °C; 40–95 °F) and should not be stored in direct sunlight. If the polyethylene bag is damaged, a new preservative solution (sodium bisulfite) must be added and air-tight sealed to prevent drying and biological growth.
- Permeate from the first hour of operation should be discarded to flush out the preservative solution.
- Elements should be immersed in a preservative solution during storage, shipping and system shutdowns to prevent biological growth and freezing. The standard storage solution contains 1% by weight sodium bisulfite or sodium metabisulfite (food grade). For short term storage (i.e. one week or less) 1% by weight sodium metabisulfite solution is adequate for preventing biological growth.
- Keep elements moist at all times after initial wetting.
- Avoid excessive pressure and flow spikes.
- Only use chemicals compatible with the membrane elements and components. Use of such chemicals may void the element limited warranty.
- Permeate pressure must always be equal or less than the feed/concentrate pressure. Damage caused by permeate back pressure voids the element limited warranty.

CSM 4" Membranes



Ref. MCRE4040-FLR

RE4040-FLR

CSM[®]

Fouling resistant RO element with low pressure for brackish water and wastewater reuse

SPECIFICATIONS:

General Features	Permeate flow rate:	1,900 GPD (7.2 m ³ /day)
	Nominal salt rejection:	99.6%
	Effective membrane area:	85 ft ² (7.9 m ²)

1. The stated product performance is based on data taken after 30 minutes of operation at the following test conditions:

- 1,500 mg/L NaCl solution at 150 psig (1.0 MPa) applied pressure
- 15% recovery
- 77 °F (25 °C)
- pH 6.5–7.0

2. Minimum salt rejection is 99.5%.

3. Permeate flow rate for each element may vary but will be no more than 15%.

4. All elements are vacuum sealed in a polyethylene bag containing 1.0% SBS (sodium bisulfite) solution and individually packaged in a cardboard box.

Membrane type:	Thin-Film Composite
Membrane material:	Polyamide (PA)
Element configuration:	Spiral-Wound, FRP Wrapping

Dimensions

Model Name	A	B	C	D	E	Part Number	
						Inter-connector	Brine Seal
RE4040-FLR	40.0 inch (1,016 mm)	4.0 inch (102 mm)	0.75 inch (19.1 mm)	1.05 inch (26.7 mm)	1.05 inch (26.7 mm)	DD004 (*)	DD003 (*)

(*) see 05-03-99-EN data sheet.

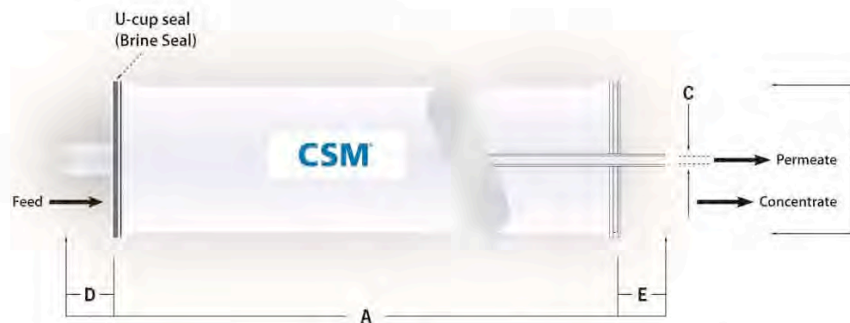

1. Each membrane element supplied with one brine seal, one interconnector (coupler) and four o-rings.
2. All RE4040 elements fit nominal 4.0 inch (102 mm) I.D. pressure vessels.

The information provided in this document is solely for informative purposes. It is the user's responsibility to ensure the appropriate usage of this product. Toray Chemical Korea Inc. assumes no obligation, liability or damages incurred for the misuse of the product or for the information provided in this document. This document does not express or implies any warranty as to the merchantability or fitness of the product.



RE4040-FLR

CSM[®]

Fouling resistant RO element with low pressure for brackish water and wastewater reuse

APPLICATION DATA:

Operating Limits

· Max. Pressure Drop / Element	15 psi (0.1 MPa)
· Max. Pressure Drop / 240" Vessel	60 psi (0.41 MPa)
· Max. Operating Pressure	600 psi (4.14 MPa)
· Max. Feed Flow Rate	18 gpm (4.09 m ³ /hr)
· Min. Concentrate Flow Rate	4 gpm (0.91 m ³ /hr)
· Max. Operating Temperature	113 °F (45 °C)
· Operating pH Range	2.0–11.0
· CIP pH Range	1.0–13.0
· Max. Turbidity	1.0 NTU
· Max. SDI (15 min)	5.0
· Max. Chlorine Concentration	< 0.1 mg/L

Design Guidelines for Various Water Sources

· Wastewater Conventional (SDI < 5)	8–12 gfd
· Wastewater Pretreated by UF/MF (SDI < 3)	10–14 gfd
· Seawater, Open Intake (SDI < 5)	7–10 gfd
· Seawater, Beach Well (SDI < 3)	8–12 gfd
· Surface Water (SDI < 5)	12–16 gfd
· Surface Water (SDI < 3)	13–17 gfd
· Well water (SDI < 3)	13–17 gfd
· RO permeate (SDI < 1)	21–30 gfd

Saturation Limits (Using Antiscalants)[†]

· Langelier Saturation Index (LSI)	<+1.5
· Stiff and Davis Saturation Index (SDSI)	<+0.5
· CaSO ₄	230% saturation
· SrSO ₄	800% saturation
· BaSO ₄	6,000% saturation
· SiO ₂	100% saturation

[†]The above saturation limits are typically accepted by proprietary antiscalant manufacturers. It is the user's responsibility to ensure proper chemical(s) and concentration are dosed ahead of the membrane system to prevent scale formation anywhere within the membrane system. Membrane elements fouled or damaged due to scale formation are not covered by the limited warranty.

GENERAL HANDLING PROCEDURES

- Elements contained in the boxes must be kept dry at room temperature (7–32°C; 40–95°F) and should not be stored in direct sunlight. If the polyethylene bag is damaged, a new preservative solution (sodium bisulfite) must be added and air-tight sealed to prevent drying and biological growth.
- Permeate from the first hour of operation should be discarded to flush out the preservative solution.
- Elements should be immersed in a preservative solution during storage, shipping and system shutdowns to prevent biological growth and freezing. The standard storage solution contains 1% by weight sodium bisulfite or sodium metabisulfite (food grade). For short term storage (i.e. one week or less) 1% by weight sodium metabisulfite solution is adequate for preventing biological growth.
- Avoid excessive pressure and flow spikes.
- Only use chemicals compatible with the membrane elements and components. Use of such chemicals may void the element limited warranty.
- Permeate pressure must always be equal or less than the feed/concentrate pressure. Damage caused by permeate back pressure voids the element limited warranty.
- Keep elements moist at all times after initial wetting.

TORAY 4" Membranes



Ref. MTML10D

TORAY

Low fouling and high tolerance RO

T M L (D)

Type	Diameter Inch	Membrane Area ft ² (m ²)	Salt Rejection %	Product Flow Rate gpd(m ³ /d)	Feed Spacer Thickness mil
TML10D	4"	73(7)	99.8	1,900(7.2)	34

1. Membrane Type		Cross Linked Fully Aromatic Polyamide Composite
2. Test Conditions	Feed Water Pressure Feed Water Temperature Feed Water Concentration Recovery Rate Feed Water pH	225 psi(1.55 MPa) 77 ° F(25 °C) 2,000 mg/l NaCl 15 % 7
3. Minimum Salt Rejection		99.65 %
4. Minimum Product Flow Rate		1,500 gpd(5.8 m ³ /d)

Dimensions

All dimensions shown in Inches (millimeter).

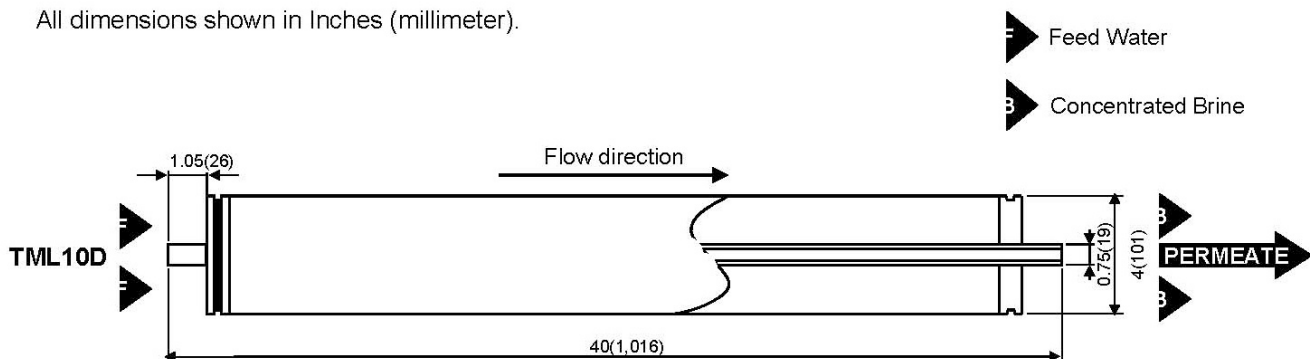



Operating Limits

Maximum Operating Pressure	600psi (4.1 MPa)
Maximum Feed Water Temperature	113° F (45°C)
Maximum Feed Water SDI ₁₅	5
Feed Water Chlorine Concentration	<0.1ppm
Feed Water pH Range, Continuous Operation	2-11
Feed Water pH Range, Chemical Cleaning	1-13
Maximum Pressure Drop per Element	15 psi (0.10 MPa)
Maximum Pressure Drop per Vessel	50 psi (0.34 MPa)

Operating Information

1. For the recommended design range, please consult the latest Toray technical bulletin, design guide lines, computer design program, and/ or call an application specialist. If the operating limits given in this Product Information Bulletin are not strictly followed, the Limited Warranty will be null and void.
2. All elements are wet tested, treated with a 1% by weight percent sodium bisulfite storage solution, and then vacuum packed in oxygen barrier bags, or treated with tested feed water solution, and then vacuum packed in oxygen barrier bags with deoxidant inside. To prevent biological growth during short term storage, shipment, or system shutdown, it is recommended that Toray elements be immersed in a protective solution containing 500 - 1,000 ppm of sodium bisulfite (food grade) dissolved in permeate.
3. The presence of free chlorine and other oxidizing agents under certain conditions, such as heavy metals which acts as oxidation catalyst in the feed water will cause unexpected oxidation of the membrane. It is strongly recommended to remove these oxidizing agents contained in feed water before operating RO system.
4. Permeate from the first hour of operation shall be discarded.
5. The customer is fully responsible for the effects of chemicals that are incompatible with the elements. Their use will void the element Limited Warranty.

Notice

1. Toray accepts no responsibility for results obtained by the application of this information or the safety or suitability of Toray's products, either alone or in combination with other products. Users are advised to make their own tests to determine the safety and suitability of each product combination for their own purposes.
2. All data may change without prior notice, due to technical modifications or production changes.



Ref. MCRE4021-SHN

RE4021-SHN

High Rejection RO element for seawater and high salinity well water

CSM[®]

SPECIFICATIONS:

General Features	Permeate flow rate:	600 GPD (2.3 m ³ /day)
	Nominal salt rejection:	99.75%
	Effective membrane area:	35 ft ² (3.3 m ²)

1. The stated product performance is based on data taken after 30 minutes of operation at the following divalent test conditions:

- 32,000 mg/L NaCl solution at 800 psig (5.5 MPa) applied pressure
- 8% recovery
- 77 °F (25 °C)
- pH 6.5–7.0

2. Minimum salt rejection is 99.6%

3. Permeate flow rate for each element may vary but will be no more than 15%.

4. All elements are vacuum sealed in a polyethylene bag containing 1.0% SBS (sodium bisulfite) solution and individually packaged in a cardboard box.

Membrane type:	Thin-Film Composite
Membrane material:	Polyamide (PA)
Element configuration:	Spiral-Wound, FRP Wrapping

Dimensions and Weight

Model Name	A	B	C	D	E
RE4021-SHN	21.0 inch (534 mm)	4.0 inch (102 mm)	0.75 inch (19.1 mm)	1.55 inch (39.5 mm)	1.55 inch (39.5 mm)

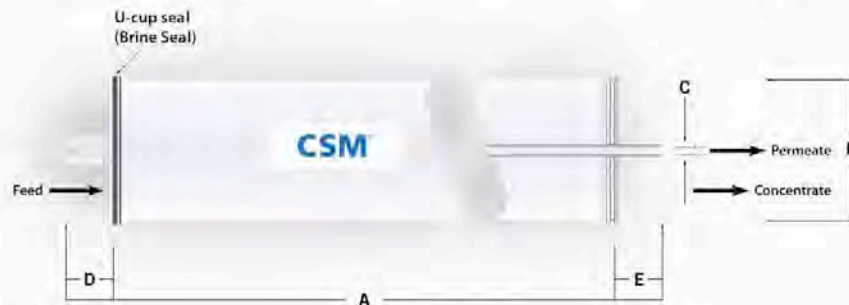

1. Each membrane element supplied with one brine seal, one interconnector (coupler) and four o-rings.
2. All RE4021 elements fit nominal 4.0 inch (102 mm) I.D. pressure vessels.

The information provided in this document is solely for informative purposes. It is the user's responsibility to ensure the appropriate usage of this product. Toray Chemical Korea Inc. assumes no obligation, liability or damages incurred for the misuse of the product or for the information provided in this document. This document does not express or implies any warranty as to the merchantability or fitness of the product.



RE402I-SHN

High Rejection RO element for seawater and high salinity well water

CSM[®]

APPLICATION DATA:

Operating Limits

· Max. Pressure Drop / Element	15 psi (0.1 MPa)
· Max. Pressure Drop / 240" Vessel	60 psi (0.41 Mpa)
· Max. Operating Pressure	1,200 psi (8.27 MPa)
· Max. Feed Flow Rate	13 gpm (2.95 m ³ /hr)
· Min. Concentrate Flow Rate	3 gpm (0.68 m ³ /hr)
· Max. Operating Temperature	113 °F (45 °C)
· Operating pH Range	2.0–11.0
· CIP pH Range	1.0–13.0
· Max. Turbidity	1.0 NTU
· Max. SDI (15 min)	5.0
· Max. Chlorine Concentration	< 0.1 mg/L

Design Guidelines for Various Water Sources

· Wastewater Conventional (SDI < 5)	8–12 gfd
· Wastewater Pretreated by UF/MF (SDI < 3)	10–14 gfd
· Seawater, Open Intake (SDI < 5)	7–10 gfd
· Seawater, Beach Well (SDI < 3)	8–12 gfd
· Surface Water (SDI < 5)	12–16 gfd
· Surface Water (SDI < 3)	13–17 gfd
· Well water (SDI < 3)	13–17 gfd
· RO permeate (SDI < 1)	21–30 gfd

Saturation Limits (Using Antiscalants)[†]

· Langelier Saturation Index (LSI)	<+1.5
· Stiff and Davis Saturation Index (SDSI)	<+0.5
· CaSO ₄	230% saturation
· SrSO ₄	800% saturation
· BaSO ₄	6,000% saturation
· SiO ₂	100% saturation

[†]The above saturation limits are typically accepted by proprietary antiscalant manufacturers. It is the user's responsibility to ensure proper chemical(s) and concentration are dosed ahead of the membrane system to prevent scale formation anywhere within the membrane system. Membrane elements fouled or damaged due to scale formation are not covered by the limited warranty.

GENERAL HANDLING PROCEDURES

- Elements contained in the boxes must be kept dry at room temperature (7–32°C; 40–95°F) and should not be stored in direct sunlight. If the polyethylene bag is damaged, a new preservative solution (sodium bisulfite) must be added and air-tight sealed to prevent drying and biological growth.
- Permeate from the first hour of operation should be discarded to flush out the preservative solution.
- Elements should be immersed in a preservative solution during storage, shipping and system shutdowns to prevent biological growth and freezing. The standard storage solution contains 1% by weight sodium bisulfite or sodium metabisulfite (food grade). For short term storage (i.e. one week or less) 1% by weight sodium metabisulfite solution is adequate for preventing biological growth.
- Keep elements moist at all times after initial wetting.
- Avoid excessive pressure and flow spikes.
- Only use chemicals compatible with the membrane elements and components. Use of such chemicals may void the element limited warranty.
- Permeate pressure must always be equal or less than the feed/concentrate pressure. Damage caused by permeate back pressure voids the element limited warranty.

TORAY 4" Membranes



Ref. MTM810C

TORAY
Innovation by Chemistry

Standard SWRO TM800C

Type	Diameter Inch	Membrane Area ft ² (m ²)	Salt Rejection %	Product Flow Rate gpd(m ³ / d)	Feed Spacer Thickness mil
TM810C	4"	73(7)	99.75	1,200(4.5)	31

1. Membrane Type		Cross Linked Fully Aromatic Polyamide Composite
2. Test Conditions	Feed Water Pressure Feed Water Temperature Feed Water Concentration Recovery Rate Feed Water pH	800 psi(5.52MPa) 77° F(25°C) 32,000 mg/l NaCl 8% 7
3. Minimum Salt Rejection		99.5%
4. Minimum Product Flow Rate		1,000gpd(3.8m ³ /d)
5. Boron Rejection (typical value)		93% at pH 8 (5mg/l Boron added to Feed water)

Dimensions

All dimensions shown in Inches (millimeter).

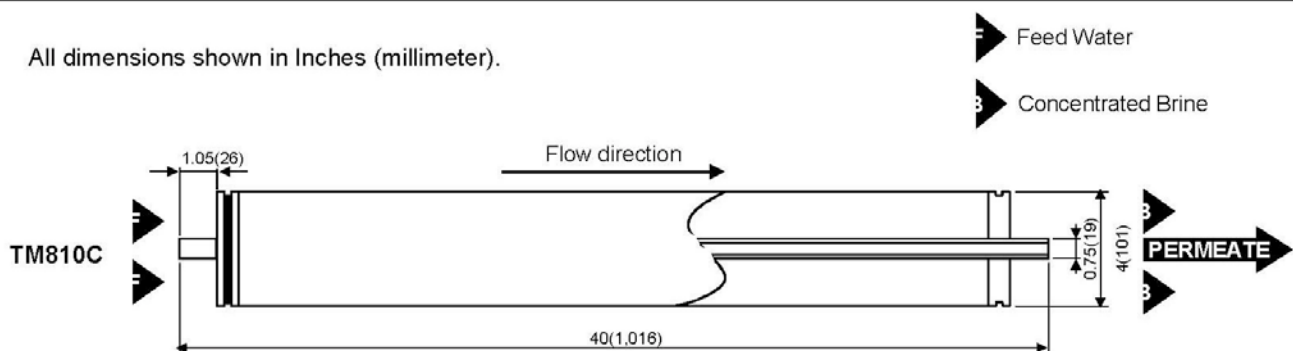



Operating Limits

Maximum Operating Pressure	1200psi (8.3 MPa)
Maximum Feed Water Temperature	113° F (45°C)
Maximum Feed Water SDI ₁₅	5
Feed Water Chlorine Concentration	Not detectable
Feed Water pH Range, Continuous Operation	2-11
Feed Water pH Range, Chemical Cleaning	1-12
Maximum Pressure Drop per Element	15 psi (0.10 MPa)
Maximum Pressure Drop per Vessel	50 psi (0.34 MPa)

Operating Information

1. For the recommended design range, please consult the latest Toray technical bulletin, design guidelines, computer design program, and/ or call an application specialist. If the operating limits given in this Product Information Bulletin are not strictly followed, the Limited Warranty will be null and void.
 2. All elements are wet tested, treated with tested feed water solution, and then vacuum packed in oxygen barrier bags with deoxidant inside. To prevent biological growth during system shutdown, it is recommended to perform 30-60 minutes flushing of Toray elements with seawater once in every two days.
 3. The presence of free chlorine and other oxidizing agents under certain conditions, such as heavy metals which acts as oxidation catalyst in the feed water will cause unexpected oxidation of the membrane. It is strongly recommended to remove these oxidizing agents contained in feed water before operating RO system.
 4. Permeate from the first hour of operation shall be discarded.
 5. The customer is fully responsible for the effects of chemicals that are incompatible with the elements. Their use will void the element Limited Warranty.
-

Notice

1. Toray accepts no responsibility for results obtained by the application of this information or the safety or suitability of Toray's products, either alone or in combination with other products. Users are advised to make their own tests to determine the safety and suitability of each product combination for their own purposes.
2. All data may change without prior notice, due to technical modifications or production changes.

TORAY 4" Membranes



Ref. MTM810V

TORAY
Innovation by Chemistry

Low energy SWRO

TM800V

Type	Diameter Inch	Membrane Area ft ² (m ²)	Salt Rejection %	Product Flow Rate gpd(m ³ / d)	Feed Spacer Thickness mil
TM810V	4"	87(8)	99.8	1,900(7.2)	28

1. Membrane Type		Cross Linked Fully Aromatic Polyamide Composite
2. Test Conditions	Feed Water Pressure Feed Water Temperature Feed Water Concentration Recovery Rate Feed Water pH	800 psi(5.52MPa) 77° F(25°C) 32,000 mg/l NaCl 8% 7
3. Minimum Salt Rejection		99.5%
4. Minimum Product Flow Rate		1,550gpd(5.9m ³ /d)
5. Boron Rejection (typical value)		92% at pH 8 (5mg/l Boron added to Feed water)

Dimensions

All dimensions shown in Inches (millimeter).

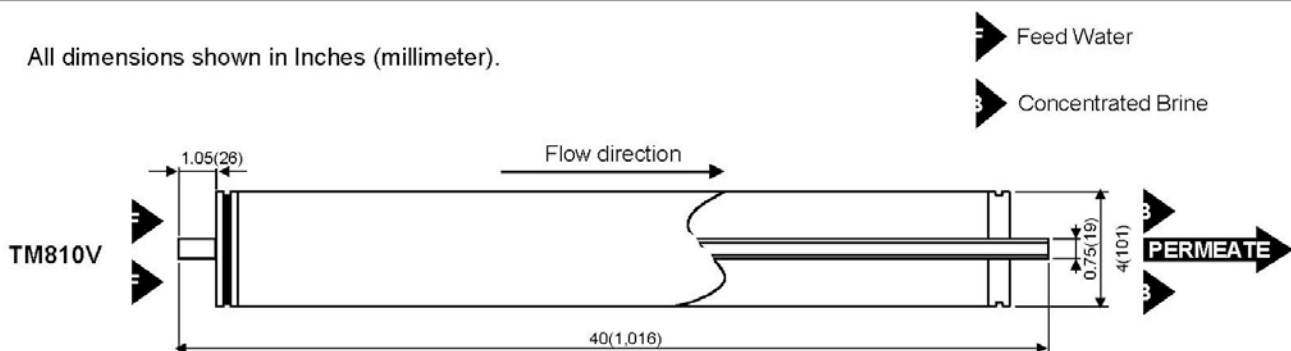



Operating Limits

Maximum Operating Pressure	1200psi (8.3 MPa)
Maximum Feed Water Temperature	113° F (45°C)
Maximum Feed Water SDI ₁₅	5
Feed Water Chlorine Concentration	Not detectable
Feed Water pH Range, Continuous Operation	2-11
Feed Water pH Range, Chemical Cleaning	1-12
Maximum Pressure Drop per Element	15 psi (0.10 MPa)
Maximum Pressure Drop per Vessel	50 psi (0.34 MPa)

Operating Information

1. For the recommended design range, please consult the latest Toray technical bulletin, design guidelines, computer design program, and/ or call an application specialist. If the operating limits given in this Product Information Bulletin are not strictly followed, the Limited Warranty will be null and void.
 2. All elements are wet tested, treated with tested feed water solution, and then vacuum packed in oxygen barrier bags with deoxidant inside. To prevent biological growth during system shutdown, it is recommended to perform 30-60 minutes flushing of Toray elements with seawater once in every two days.
 3. The presence of free chlorine and other oxidizing agents under certain conditions, such as heavy metals which acts as oxidation catalyst in the feed water will cause unexpected oxidation of the membrane. It is strongly recommended to remove these oxidizing agents contained in feed water before operating RO system.
 4. Permeate from the first hour of operation shall be discarded.
 5. The customer is fully responsible for the effects of chemicals that are incompatible with the elements. Their use will void the element Limited Warranty.
-

Notice

1. Toray accepts no responsibility for results obtained by the application of this information or the safety or suitability of Toray's products, either alone or in combination with other products. Users are advised to make their own tests to determine the safety and suitability of each product combination for their own purposes.
2. All data may change without prior notice, due to technical modifications or production changes.



Ref. MCNE4040-90

NE4040-90

Normal grade NF element with high monovalent ion rejection

CSM[®]

SPECIFICATIONS:

General Features	Permeate flow rate :	1,600 GPD (6.0 m ³ /day)
	Monovalent ion rejection (NaCl)¹:	85.0 – 95.0%
	Divalent ion rejection (CaCl₂)²:	90.0 – 95.0%
	Effective membrane area :	85 ft ² (7.9 m ²)

1. The stated product performance is based on data taken after 30 minutes of operation at the following monovalent test conditions:

- 2,000 mg/L NaCl solution at 75 psig (0.5 MPa) applied pressure
- 15% recovery
- 77 °F (25 °C)
- pH 6.5–7.0

2. The stated product performance is based on data taken after 30 minutes of operation at the following divalent test conditions:

- 500 mg/L CaCl₂ solution at 75 psig (0.5 MPa) applied pressure
- 15% recovery
- 77 °F (25 °C)
- pH 6.5–7.0

3. MgSO₄ rejection is 97.0%. (Test conditions are equivalent with NaCl)

4. Permeate flow rate for each element may vary but will be no more than 15%.

5. All elements are vacuum sealed in a polyethylene bag containing 1.0% SBS (sodium bisulfite) solution and individually packaged in a cardboard box.

Membrane type:	Thin-Film Composite
Membrane material:	Polyamide (PA)
Element configuration:	Spiral-Wound, FRP Wrapping

Dimensions

Model Name	A	B	C	D	E
NE4040-90	40.0 inch (1,016 mm)	4.0 inch (102 mm)	0.75 inch (19.1 mm)	1.61 inch (41 mm)	1.61 inch (41 mm)



1. Each membrane element supplied with one brine seal, one interconnector (coupler) and four o-rings.
2. All NE4040 elements fit nominal 4.0 inch (102 mm) I.D. pressure vessels.

The information provided in this document is solely for informative purposes. It is the user's responsibility to ensure the appropriate usage of this product. Woongjin Chemical assumes no obligation, liability or damages incurred for the misuse of the product or for the information provided in this document. This document does not express or imply any warranty as to the merchantability or fitness of the product.



NE4040-90

Normal grade NF element with high monovalent ion rejection

CSM®

APPLICATION DATA:

Operating Limits

· Max. Pressure Drop / Element	15 psi (0.1 MPa)
· Max. Pressure Drop / 240" Vessel	60 psi (0.41 Mpa)
· Max. Operating Pressure	600 psi (4.14 MPa)
· Max. Feed Flow Rate	18 gpm (4.09 m ³ /hr)
· Min. Concentrate Flow Rate	4 gpm (0.91 m ³ /hr)
· Max. Operating Temperature	113 °F (45 °C)
· Operating pH Range	2.0–11.0
· CIP pH Range	1.0–13.0
· Max. Turbidity	1.0 NTU
· Max. SDI (15 min)	5.0
· Max. Chlorine Concentration	< 0.1 mg/L

Design Guidelines for Various Water Sources

· Wastewater Conventional (SDI < 5)	8–12 gfd
· Wastewater Pretreated by UF/MF (SDI < 3)	10–14 gfd
· Seawater; Open Intake (SDI < 5)	7–10 gfd
· Seawater; Beach Well (SDI < 3)	8–12 gfd
· Surface Water (SDI < 5)	12–16 gfd
· Surface Water (SDI < 3)	13–17 gfd
· Well water (SDI < 3)	13–17 gfd
· RO permeate (SDI < 1)	21–30 gfd

Saturation Limits (Using Antiscalants)[†]

· Langelier Saturation Index (LSI)	<+1.5
· Stiff and Davis Saturation Index (SDSI)	<+0.5
· CaSO ₄	230% saturation
· SrSO ₄	800% saturation
· BaSO ₄	6,000% saturation
· SiO ₂	100% saturation

[†]The above saturation limits are typically accepted by proprietary antiscalant manufacturers. It is the user's responsibility to ensure proper chemical(s) and concentration are dosed ahead of the membrane system to prevent scale formation anywhere within the membrane system. Membrane elements fouled or damaged due to scale formation are not covered by the limited warranty.

GENERAL HANDLING PROCEDURES

- Elements contained in the boxes must be kept dry at room temperature (7–32°C; 40–95°F) and should not be stored in direct sunlight. If the polyethylene bag is damaged, a new preservative solution (sodium bisulfite) must be added and air-tight sealed to prevent drying and biological growth.
- Permeate from the first hour of operation should be discarded to flush out the preservative solution.
- Elements should be immersed in a preservative solution during storage, shipping and system shutdowns to prevent biological growth and freezing. The standard storage solution contains 1% by weight sodium bisulfite or sodium metabisulfite (food grade). For short term storage (i.e. one week or less) 1% by weight sodium metabisulfite solution is adequate for preventing biological growth.
- Keep elements moist at all times after initial wetting.
- Avoid excessive pressure and flow spikes.
- Only use chemicals compatible with the membrane elements and components. Use of such chemicals may void the element limited warranty.
- Permeate pressure must always be equal or less than the feed/concentrate pressure. Damage caused by permeate back pressure voids the element limited warranty.



Ref. MCNE4040-70

NE4040-70

Normal grade NF element with high monovalent ion rejection

CSM

SPECIFICATIONS:

General Features	Permeate flow rate¹:	1,500 GPD (5.7 m ³ /day)
	Monovalent ion rejection (NaCl)¹:	40.0 – 70.0%
	Divalent ion rejection (CaCl₂)²:	45.0 – 70.0%
	Effective membrane area:	85 ft ² (7.9 m ²)

1. The stated product performance is based on data taken after 30 minutes of operation at the following monovalent test conditions:

- 2,000 mg/L NaCl solution at 75 psig (0.5 MPa) applied pressure
- 15% recovery
- 77 °F (25 °C)
- pH 6.5–7.0

2. The stated product performance is based on data taken after 30 minutes of operation at the following divalent test conditions:

- 500 mg/L CaCl₂ solution at 75 psig (0.5 MPa) applied pressure
- 15% recovery
- 77 °F (25 °C)
- pH 6.5–7.0

3. MgSO₄ rejection is 97.0%. (Test conditions are equivalent with NaCl)

4. Permeate flow rate for each element may vary but will be no more than 15%.

5. All elements are vacuum sealed in a polyethylene bag containing 1.0% SBS (sodium bisulfite) solution and individually packaged in a cardboard box.

Membrane type:	Thin-Film Composite
Membrane material:	Polyamide (PA)
Element configuration:	Spiral-Wound, FRP Wrapping

Dimensions

Model Name	A	B	C	D	E
NE4040-70	40.0 inch (1,016 mm)	4.0 inch (102 mm)	0.75 inch (19.1 mm)	1.61 inch (41 mm)	1.61 inch (41 mm)



1. Each membrane element supplied with one brine seal, one interconnector (coupler) and four o-rings.
2. All NE4040 elements fit nominal 4.0 inch (102 mm) I.D. pressure vessels.

The information provided in this document is solely for informative purposes. It is the user's responsibility to ensure the appropriate usage of this product. Woongjin Chemical assumes no obligation, liability or damages incurred for the misuse of the product or for the information provided in this document. This document does not express or imply any warranty as to the merchantability or fitness of the product.



NE4040-70

Normal grade NF element with medium monovalent ion rejection

CSM[®]

APPLICATION DATA:

Operating Limits

· Max. Pressure Drop / Element	15 psi (0.1 MPa)
· Max. Pressure Drop / 240" Vessel	60 psi (0.41 MPa)
· Max. Operating Pressure	600 psi (4.14 MPa)
· Max. Feed Flow Rate	18 gpm (4.09 m ³ /hr)
· Min. Concentrate Flow Rate	4 gpm (0.91 m ³ /hr)
· Max. Operating Temperature	113 °F (45 °C)
· Operating pH Range	2.0–11.0
· CIP pH Range	1.0–13.0
· Max. Turbidity	1.0 NTU
· Max. SDI (15 min)	5.0
· Max. Chlorine Concentration	< 0.1 mg/L

Design Guidelines for Various Water Sources

· Wastewater Conventional (SDI < 5)	8–12 gfd
· Wastewater Pretreated by UF/MF (SDI < 3)	10–14 gfd
· Seawater, Open Intake (SDI < 5)	7–10 gfd
· Seawater, Beach Well (SDI < 3)	8–12 gfd
· Surface Water (SDI < 5)	12–16 gfd
· Surface Water (SDI < 3)	13–17 gfd
· Well water (SDI < 3)	13–17 gfd
· RO permeate (SDI < 1)	21–30 gfd

Saturation Limits (Using Antiscalants)[†]

· Langelier Saturation Index (LSI)	<+1.5
· Stiff and Davis Saturation Index (SDSI)	<+0.5
· CaSO ₄	230% saturation
· SrSO ₄	800% saturation
· BaSO ₄	6,000% saturation
· SiO ₂	100% saturation

[†]The above saturation limits are typically accepted by proprietary antiscalant manufacturers. It is the user's responsibility to ensure proper chemical(s) and concentration are dosed ahead of the membrane system to prevent scale formation anywhere within the membrane system. Membrane elements fouled or damaged due to scale formation are not covered by the limited warranty.

GENERAL HANDLING PROCEDURES

- Elements contained in the boxes must be kept dry at room temperature (7–32°C; 40–95°F) and should not be stored in direct sunlight. If the polyethylene bag is damaged, a new preservative solution (sodium bisulfite) must be added and air-tight sealed to prevent drying and biological growth.
- Permeate from the first hour of operation should be discarded to flush out the preservative solution.
- Elements should be immersed in a preservative solution during storage, shipping and system shutdowns to prevent biological growth and freezing. The standard storage solution contains 1% by weight sodium bisulfite or sodium metabisulfite (food grade). For short term storage (i.e. one week or less) 1% by weight sodium metabisulfite solution is adequate for preventing biological growth.
- Keep elements moist at all times after initial wetting.
- Avoid excessive pressure and flow spikes.
- Only use chemicals compatible with the membrane elements and components. Use of such chemicals may void the element limited warranty.
- Permeate pressure must always be equal or less than the feed/concentrate pressure. Damage caused by permeate back pressure voids the element limited warranty.

CSM 4" Membranes



Ref. MCNE4040-40

NE4040-40

High productivity NF element

CSM[®]

SPECIFICATIONS:

General Features	Permeate flow rate¹:	2.500 GPD (9.45 m ³ /day)
	Monovalent ion rejection (NaCl):	30 –60%
	Effective membrane area:	85 ft ² (7.9 m ²)

1. The stated product performance is based on data taken after 30 minutes of operation at the following monovalent test conditions:

- 2,000 mg/L NaCl solution at 75 psig (0.5 MPa) applied pressure
- 15% recovery
- 77 °F (25 °C)
- pH 6.5–7.0

2. Permeate flow rate for each element may vary but will be no more than 20%.

3. All elements are vacuum sealed in a polyethylene bag containing 1.0% SBS (sodium bisulfite) solution and individually packaged in a cardboard box.

Membrane type:	Thin-Film Composite
Membrane material:	Polyamide (PA)
Element configuration:	Spiral-Wound, FRP Wrapping

Dimensions and Weight

Model Name	A	B	C	D	E	Part Number	
						Inter-connector	Brine Seal
NE4040-40	40.0 inch (1,016 mm)	4.0 inch (102 mm)	0.75 inch (19.1 mm)	1.05 inch (26.7 mm)	1.05 inch (26.7 mm)	DD004 (*)	DD003 (*)

(*) see 05-03-99-EN data sheet.

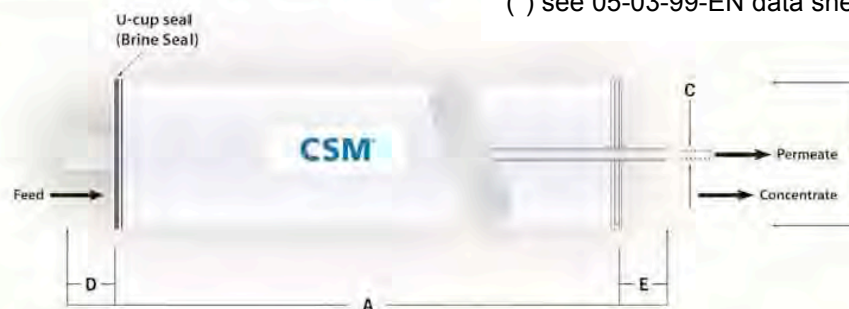

1. Each membrane element supplied with one brine seal, one interconnector (coupler) and four o-rings.
2. All NE4040 elements fit nominal 4.0 inch (102 mm) I.D. pressure vessels.

The information provided in this document is solely for informative purposes. It is the user's responsibility to ensure the appropriate usage of this product. Woongjin Chemical assumes no obligation, liability or damages incurred for the misuse of the product or for the information provided in this document. This document does not express or imply any warranty as to the merchantability or fitness of the product.



NE4040-40

High productivity NF element

CSM[®]

APPLICATION DATA:

Operating Limits

• Max. Pressure Drop / Element	15 psi (0.1 MPa)
• Max. Pressure Drop / 240" Vessel	60 psi (0.41 MPa)
• Max. Operating Pressure	600 psi (4.14 MPa)
• Max. Feed Flow Rate	18 gpm (4.09 m ³ /hr)
• Min. Concentrate Flow Rate	4 gpm (0.91 m ³ /hr)
• Max. Operating Temperature	113 °F (45 °C)
• Operating pH Range	2.0–11.0
• CIP pH Range	1.0–13.0
• Max. Turbidity	1.0 NTU
• Max. SDI (15 min)	5.0
• Max. Chlorine Concentration	< 0.1 mg/L

Design Guidelines for Various Water Sources

• Wastewater Conventional (SDI < 5)	8–12 gfd
• Wastewater Pretreated by UF/MF (SDI < 3)	10–14 gfd
• Seawater, Open Intake (SDI < 5)	7–10 gfd
• Seawater, Beach Well (SDI < 3)	8–12 gfd
• Surface Water (SDI < 5)	12–16 gfd
• Surface Water (SDI < 3)	13–17 gfd
• Well water (SDI < 3)	13–17 gfd
• RO permeate (SDI < 1)	21–30 gfd

Saturation Limits (Using Antiscalants)[†]

• Langelier Saturation Index (LSI)	<+ 1.5
• Stiff and Davis Saturation Index (SDSI)	<+0.5
• CaSO ₄	230% saturation
• SrSO ₄	800% saturation
• BaSO ₄	6,000% saturation
• SiO ₂	100% saturation

[†]The above saturation limits are typically accepted by proprietary antiscalant manufacturers. It is the user's responsibility to ensure proper chemical(s) and concentration are dosed ahead of the membrane system to prevent scale formation anywhere within the membrane system. Membrane elements fouled or damaged due to scale formation are not covered by the limited warranty.

GENERAL HANDLING PROCEDURES

- Elements contained in the boxes must be kept dry at room temperature (7–32°C; 40–95°F) and should not be stored in direct sunlight. If the polyethylene bag is damaged, a new preservative solution (sodium bisulfite) must be added and air-tight sealed to prevent drying and biological growth.
- Permeate from the first hour of operation should be discarded to flush out the preservative solution.
- Elements should be immersed in a preservative solution during storage, shipping and system shutdowns to prevent biological growth and freezing. The standard storage solution contains 1% by weight sodium bisulfite or sodium metabisulfite (food grade). For short term storage (i.e. one week or less) 1% by weight sodium metabisulfite solution is adequate for preventing biological growth.
- Keep elements moist at all times after initial wetting.
- Avoid excessive pressure and flow spikes.
- Only use chemicals compatible with the membrane elements and components. Use of such chemicals may void the element limited warranty.
- Permeate pressure must always be equal or less than the feed/concentrate pressure. Damage caused by permeate back pressure voids the element limited warranty.

CSM 4" Membranes



Ref. MCUE4040-PF

UE4040-PF

Normal grade UF element for RO pretreatment

CSM®

SPECIFICATIONS:

General Features	Permeate flow rate:	3,500 GPD (13.2 m ³ /day)
	Molecular Weight Cut Off:	50-100K (Daltons)
	Effective membrane area:	75 ft ² (7.0 m ²)

1. The stated product performance is based on data taken after 30 minutes of operation at the following test conditions:

- **Concentration: pure water**
- **Pressure: 20 psig**
- **77 °F (25 °C)**

2. Permeate flow rate for each element may vary but will be no more than 20%.

3. All elements are vacuum sealed in a polyethylene bag containing 1.0% SBS (sodium bisulfite) solution and individually packaged in a cardboard box.

Membrane type:	Homogenous Asymmetric Flat Sheet
Membrane material:	Polysulfone (PSF)
Element configuration:	Spiral-Wound, Taping

Dimensions

Model Name	A	B	C	D	E	Part Number	
						Inter-connector	Brine Seal
UE4040-PF	40.0 inch (1,016 mm)	4.0 inch (102 mm)	0.75 inch (19.1 mm)	1.05 inch (26.7 mm)	1.05 inch (26.7 mm)	DD004 (*)	DD003 (*)

(*) see 05-03-99-EN data sheet.



1. Each membrane element supplied with one brine seal, one interconnector (coupler) and four o-rings.
2. All UE4040 elements fit nominal 4.0 inch (102 mm) I.D. pressure vessels.

The information provided in this document is solely for informative purposes. It is the user's responsibility to ensure the appropriate usage of this product. Woongjin Chemical assumes no obligation, liability or damages incurred for the misuse of the product or for the information provided in this document. This document does not express or implies any warranty as to the merchantability or fitness of the product.



UE4040-PF

Normal grade UF element for RO pretreatment

APPLICATION DATA:

Operating Limits

· Max. Pressure Drop / Element	15 psi (0.1 MPa)
· Max. Pressure Drop / 240" Vessel	60 psi (0.41 Mpa)
· Max. Operating Pressure	400 psi (2.78 MPa)
· Max. Feed Flow Rate	18 gpm (4.0 m ³ /hr)
· Min. Concentrate Flow Rate	4 gpm (0.91 m ³ /hr)
· Max. Operating Temperature	113 °F (45 °C)
· Operating pH Range	2.0–11.0
· CIP pH Range	1.0–13.0
· Max. Turbidity	1.0 NTU
· Max. SDI (15 min)	5.0

Design Guidelines for Various Water Sources

· Surface Water (SDI < 5)	10–15 gfd
· Softened Water (SDI < 3)	15–20 gfd
· RO permeate (SDI < 1)	21–30 gfd

GENERAL HANDLING PROCEDURES

- Elements contained in the boxes must be kept dry at room temperature (7–32°C; 40–95°F) and should not be stored in direct sunlight. If the polyethylene bag is damaged, a new preservative solution (sodium bisulfite) must be added and air-tight sealed to prevent drying and biological growth.
- Permeate from the first hour of operation should be discarded to flush out the preservative solution.
- Elements should be immersed in a preservative solution during storage, shipping and system shutdowns to prevent biological growth and freezing. The standard storage solution contains 1% by weight sodium bisulfite or sodium metabisulfite (food grade). For short term storage (i.e. one week or less) 1% by weight sodium metabisulfite solution is adequate for preventing biological growth.
- Keep elements moist at all times after initial wetting.
- Avoid excessive pressure and flow spikes.
- Only use chemicals compatible with the membrane elements and components. Use of such chemicals may void the element limited warranty.
- Permeate pressure must always be equal or less than the feed/concentrate pressure. Damage caused by permeate back pressure voids the element limited warranty.

TORAY CSM 8" Membranes



LOW PRESSURE LPM MEMBRANES					
REF.	OLD REF.	MODEL	NSF/ANSI	DM174-2004	
MCRE8040-BLN	EA700	RE8040-BLN	Standard 61	Compliant	
MCRE8040-BLN440	EA701	RE8040-BLN440	-	Compliant	
MCRE8040-BLR	EA702	RE8040-BLR	Standard 61	Compliant	
MCRE8040-BLR440	EA703	RE8040-BLR440	-	Compliant	
MCRE8040-BLF	EA704	RE8040-BLF	Standard 61	Compliant	
MCRE8040-BLF440	EA705	RE8040-BLF440	-	Compliant	
MTMH20A-400C	-	TMH20A-400C	-	-	
MTMG20D-400	-	TMG20D-400	-	-	

BRACKISH WATER BWM MEMBRANES					
REF.	OLD REF.	MODEL	NSF/ANSI	DM174-2004	
MCRE8040-BN	EA710	RE8040-BN	Standard 61	Compliant	
MCRE8040-BE	EA711	RE8040-BE	Standard 61	Compliant	
MCRE8040-BE440	EA712	RE8040-BE440	Standard 61	Compliant	
MCRE8040-BR	EA713	RE8040-BR	-	Compliant	
MCRE8040-BR400	EA714	RE8040-BR400	-	Compliant	
MTM720D-400	-	TM720D-400	-	-	

CHLORINE RESISTANT CRM MEMBRANES					
REF.	OLD REF.	MODEL	NSF/ANSI	DM174-2004	
MCRE8040-CE (*)	EA715	RE8040-CE	Standard 61	Compliant	

FOULING RESISTANT FRM MEMBRANES					
REF.	OLD REF.	MODEL	NSF/ANSI	DM174-2004	
MCRE8040-FEN34	EA720A	RE8040-FEn34	-	Compliant	
MCRE8040-FEN	EA721	RE8040-FEn	Standard 61	Compliant	
MCRE8040-FEN440	EA722	RE8040-FEn440	Standard 61	Compliant	
MCRE8040-FL (*)	EA723	RE8040-FL	-	Compliant	
MCRE8040-FLR	EA724	RE8040-FLR	-	Compliant	
MTML20D-400	-	TML20D-400	-	-	

SEA WATER SWM MEMBRANES					
REF.	OLD REF.	MODEL	NSF/ANSI	DM174-2004	
MTM820M-400	EA734	TM820M-400	-	-	
MTM820M-440	-	TM820M-440	-	-	
MTM820V-400	EA732	TM820V-400	-	-	

NANOFILTRATION NFM MEMBRANES					
REF.	OLD REF.	MODEL	NSF/ANSI	DM174-2004	
MCNE8040-90	EA740	NE8040-90	Standard 61	Compliant	
MCNE8040-70 (*)	EA741	NE8040-70	Standard 61	Compliant	
MCNE8040-40 (*)	EA742	NE8040-40	Standard 61	Compliant	

ULTRA PURE WATER UPWM MEMBRANES					
REF.	OLD REF.	MODEL	NSF/ANSI	DM174-2004	
MCRE8040-UE (*)	EA750	RE8040-UE	-	Compliant	
MCRE8040-HUE (*)	EA751	RE8040-HUE	-	Compliant	
MCRE8040-HUE440 (*)	EA752	RE8040-HUE440	-	Compliant	
MCRE8040-UL (*)	EA753	RE8040-UL	-	Compliant	

ULTRAFILTRATION UFM MEMBRANES					
REF.	OLD REF.	MODEL	NSF/ANSI	DM174-2004	
MCUE8040-PF (*)	EA755	UE8040-PF	-	-	

(*) not available in stock.



Ref. MCRE8040-BLN

RE8040-BLN

Low pressure grade RO element for brackish water

CSM[®]

SPECIFICATIONS:

General Features	Permeate flow rate:	12,000 GPD (45.4 m ³ /day)
	Nominal salt rejection:	99.2%
	Effective membrane area:	400 ft ² (37.2 m ²)

1. The stated product performance is based on data taken after 30 minutes of operation at the following test conditions:

- 1,500 mg/L NaCl solution at 150 psig (1.0 MPa) applied pressure
- 15% recovery
- 77 °F (25 °C)
- pH 6.5–7.0

2. Minimum salt rejection is 99.0%.

3. Permeate flow rate for each element may vary but will be no more than 10%.

4. All elements are vacuum sealed in a polyethylene bag containing 1.0% SBS (sodium bisulfite) solution and individually packaged in a cardboard box.

Membrane type:	Thin-Film Composite
Membrane material:	Polyamide (PA)
Element configuration:	Spiral-Wound, FRP Wrapping

Dimensions **A** = 40.0 inch (1,016 mm) **B** = 8.0 inch (201 mm) **C** = 1.12 inch (28 mm)



1. Each membrane element supplied with one brine seal, one interconnector (coupler) and four o-rings.
2. All RE8040 elements fit nominal 8.0 inch (201 mm) I.D. pressure vessels.

The information provided in this document is solely for informative purposes. It is the user's responsibility to ensure the appropriate usage of this product. Woongjin Chemical assumes no obligation, liability or damages incurred for the misuse of the product or for the information provided in this document. This document does not express or implies any warranty as to the merchantability or fitness of the product.



RE8040-BLN

Low pressure grade RO element for brackish water

CSM[®]

APPLICATION DATA:

Operating Limits

• Max. Pressure Drop / Element	15 psi (0.1 MPa)
• Max. Pressure Drop / 240" Vessel	60 psi (0.41 Mpa)
• Max. Operating Pressure	600 psi (4.14 MPa)
• Max. Feed Flow Rate	75 gpm (17.0 m ³ /hr)
• Min. Concentrate Flow Rate	16 gpm (3.6 m ³ /hr)
• Max. Operating Temperature	113 °F (45 °C)
• Operating pH Range	2.0–11.0
• CIP pH Range	1.0–13.0
• Max. Turbidity	1.0 NTU
• Max. SDI (15 min)	5.0
• Max. Chlorine Concentration	< 0.1 mg/L

Design Guidelines for Various Water Sources

• Wastewater Conventional (SDI < 5)	8–12 gfd
• Wastewater Pretreated by UF/MF (SDI < 3)	10–14 gfd
• Seawater, Open Intake (SDI < 5)	7–10 gfd
• Seawater, Beach Well (SDI < 3)	8–12 gfd
• Surface Water (SDI < 5)	12–16 gfd
• Surface Water (SDI < 3)	13–17 gfd
• Well water (SDI < 3)	13–17 gfd
• RO permeate (SDI < 1)	21–30 gfd

Saturation Limits (Using Antiscalants)[†]

• Langlier Saturation Index (LSI)	<+1.5
• Stiff and Davis Saturation Index (SDSI)	<+0.5
• CaSO ₄	230% saturation
• SrSO ₄	800% saturation
• BaSO ₄	6,000% saturation
• SiO ₂	100% saturation

[†]The above saturation limits are typically accepted by proprietary antiscalant manufacturers. It is the user's responsibility to ensure proper chemical(s) and concentration are dosed ahead of the membrane system to prevent scale formation anywhere within the membrane system. Membrane elements fouled or damaged due to scale formation are not covered by the limited warranty.

GENERAL HANDLING PROCEDURES

- Elements contained in the boxes must be kept dry at room temperature (7–32°C; 40–95°F) and should not be stored in direct sunlight. If the polyethylene bag is damaged, a new preservative solution (sodium bisulfite) must be added and air-tight sealed to prevent drying and biological growth.
- Permeate from the first hour of operation should be discarded to flush out the preservative solution.
- Elements should be immersed in a preservative solution during storage, shipping and system shutdowns to prevent biological growth and freezing. The standard storage solution contains 1% by weight sodium bisulfite or sodium metabisulfite (food grade). For short term storage (i.e. one week or less) 1% by weight sodium metabisulfite solution is adequate for preventing biological growth.
- Keep elements moist at all times after initial wetting.
- Avoid excessive pressure and flow spikes.
- Only use chemicals compatible with the membrane elements and components. Use of such chemicals may void the element limited warranty.
- Permeate pressure must always be equal or less than the feed/concentrate pressure. Damage caused by permeate back pressure voids the element limited warranty.



Ref. MCRE8040-BLN440

RE8040-BLN440

Low pressure grade RO element with extended area for brackish water

SPECIFICATIONS:

General Features	Permeate flow rate:	13,000 GPD (49.2 m ³ /day)
	Nominal salt rejection:	99.2%
	Effective membrane area:	440 ft ² (40.9 m ²)

1. The stated product performance is based on data taken after 30 minutes of operation at the following test conditions:

- 1,500 mg/L NaCl solution at 150 psig (1.0 MPa) applied pressure
- 15% recovery
- 77 °F (25 °C)
- pH 6.5–7.0

2. Minimum salt rejection is 99.0%.

3. Permeate flow rate for each element may vary but will be no more than 15%.

4. All elements are vacuum sealed in a polyethylene bag containing 1.0% SBS (sodium bisulfite) solution and individually packaged in a cardboard box.

Membrane type:	Thin-Film Composite
Membrane material:	Polyamide (PA)
Element configuration:	Spiral-Wound, FRP Wrapping

Dimensions and Weight

Model Name	A	B	C	Weight	Part Number	
					Inter-connector	Brine Seal
RE8040-BLN440	40.0 inch (1,016 mm)	8.0 inch (201 mm)	1.12 inch (28 mm)	15 kg	40000308	40000309

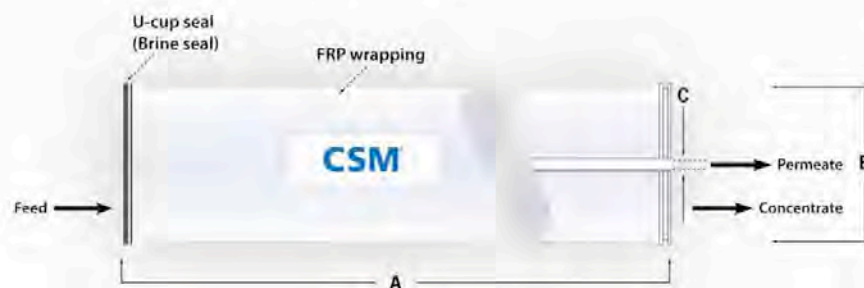

1. Each membrane element supplied with one brine seal, one interconnector (coupler) and four o-rings.
2. All RE8040 elements fit nominal 8.0 inch (201 mm) I.D. pressure vessels.
3. RE8040-BLN440 element can be also made with a 1.5 inch (38mm) diameter central pipe.

The information provided in this document is solely for informative purposes. It is the user's responsibility to ensure the appropriate usage of this product. Woongjin Chemical assumes no obligation, liability or damages incurred for the misuse of the product or for the information provided in this document. This document does not express or implies any warranty as to the merchantability or fitness of the product.



RE8040-BLN440

Low pressure grade RO element with extended area for brackish water

CSM®

APPLICATION DATA:

Operating Limits

· Max. Pressure Drop / Element	15 psi (0.1 MPa)
· Max. Pressure Drop / 240" Vessel	60 psi (0.41 MPa)
· Max. Operating Pressure	600 psi (4.14 MPa)
· Max. Feed Flow Rate	75 gpm (17.0 m ³ /hr)
· Min. Concentrate Flow Rate	16 gpm (3.6 m ³ /hr)
· Max. Operating Temperature	113 °F (45 °C)
· Operating pH Range	2.0–11.0
· CIP pH Range	1.0–13.0
· Max. Turbidity	1.0 NTU
· Max. SDI (15 min)	5.0
· Max. Chlorine Concentration	< 0.1 mg/L

Design Guidelines for Various Water Sources

· Wastewater Conventional (SDI < 5)	8–12 gfd
· Wastewater Pretreated by UF/MF (SDI < 3)	10–14 gfd
· Seawater, Open Intake (SDI < 5)	7–10 gfd
· Seawater, Beach Well (SDI < 3)	8–12 gfd
· Surface Water (SDI < 5)	12–16 gfd
· Surface Water (SDI < 3)	13–17 gfd
· Well water (SDI < 3)	13–17 gfd
· RO permeate (SDI < 1)	21–30 gfd

Saturation Limits (Using Antiscalants)[†]

· Langelier Saturation Index (LSI)	<+ 1.5
· Stiff and Davis Saturation Index (SDSI)	<+0.5
· CaSO ₄	230% saturation
· SrSO ₄	800% saturation
· BaSO ₄	6,000% saturation
· SiO ₂	100% saturation

[†]The above saturation limits are typically accepted by proprietary antiscalant manufacturers. It is the user's responsibility to ensure proper chemical(s) and concentration are dosed ahead of the membrane system to prevent scale formation anywhere within the membrane system. Membrane elements fouled or damaged due to scale formation are not covered by the limited warranty.

GENERAL HANDLING PROCEDURES

- Elements contained in the boxes must be kept dry at room temperature (7–32°C; 40–95°F) and should not be stored in direct sunlight. If the polyethylene bag is damaged, a new preservative solution (sodium bisulfite) must be added and air-tight sealed to prevent drying and biological growth.
- Permeate from the first hour of operation should be discarded to flush out the preservative solution.
- Elements should be immersed in a preservative solution during storage, shipping and system shutdowns to prevent biological growth and freezing. The standard storage solution contains 1% by weight sodium bisulfite or sodium metabisulfite (food grade). For short term storage (i.e. one week or less) 1% by weight sodium metabisulfite solution is adequate for preventing biological growth.
- Keep elements moist at all times after initial wetting.
- Avoid excessive pressure and flow spikes.
- Only use chemicals compatible with the membrane elements and components. Use of such chemicals may void the element limited warranty.
- Permeate pressure must always be equal or less than the feed/concentrate pressure. Damage caused by permeate back pressure voids the element limited warranty.

CSM 8" Membranes



Ref. MCRE8040-BLR

RE8040-BLR

Low pressure grade RO element for brackish water

CSM[®]

SPECIFICATIONS:

General Features	Permeate flow rate:	9,000 GPD (34.0 m ³ /day)
	Nominal salt rejection:	99.6%
	Effective membrane area:	400 ft ² (37.2 m ²)

1. The stated product performance is based on data taken after 30 minutes of operation at the following test conditions:

- 1,500 mg/L NaCl solution at 150 psig (1.0 MPa) applied pressure
- 15% recovery
- 77 °F (25 °C)
- pH 6.5–7.0

2. Minimum salt rejection is 99.5%.

3. Permeate flow rate for each element may vary but will be no more than 10%.

4. All elements are vacuum sealed in a polyethylene bag containing 1.0% SBS (sodium bisulfite) solution and individually packaged in a cardboard box.

Membrane type:	Thin-Film Composite
Membrane material:	Polyamide (PA)
Element configuration:	Spiral-Wound, FRP Wrapping

Dimensions A = 40.0 inch (1,016 mm) B = 8.0 inch (201 mm) C = 1.12 inch (28 mm)



1. Each membrane element supplied with one brine seal, one interconnector (coupler) and four o-rings.
2. All RE8040 elements fit nominal 8.0 inch (201 mm) I.D. pressure vessels.

The information provided in this document is solely for informative purposes. It is the user's responsibility to ensure the appropriate usage of this product. Woongjin Chemical assumes no obligation, liability or damages incurred for the misuse of the product or for the information provided in this document. This document does not express or imply any warranty as to the merchantability or fitness of the product.



RE8040-BLR

Normal low pressure grade RO element for brackish water

CSM[®]

APPLICATION DATA:

Operating Limits

· Max. Pressure Drop / Element	15 psi (0.1 MPa)
· Max. Pressure Drop / 240" Vessel	60 psi (0.41 MPa)
· Max. Operating Pressure	600 psi (4.14 MPa)
· Max. Feed Flow Rate	75 gpm (17.0 m ³ /hr)
· Min. Concentrate Flow Rate	16 gpm (3.6 m ³ /hr)
· Max. Operating Temperature	113 °F (45 °C)
· Operating pH Range	2.0–11.0
· CIP pH Range	1.0–13.0
· Max. Turbidity	1.0 NTU
· Max. SDI (15 min)	5.0
· Max. Chlorine Concentration	< 0.1 mg/L

Design Guidelines for Various Water Sources

· Wastewater Conventional (SDI < 5)	8–12 gfd
· Wastewater Pretreated by UF/MF (SDI < 3)	10–14 gfd
· Seawater, Open Intake (SDI < 5)	7–10 gfd
· Seawater, Beach Well (SDI < 3)	8–12 gfd
· Surface Water (SDI < 5)	12–16 gfd
· Surface Water (SDI < 3)	13–17 gfd
· Well water (SDI < 3)	13–17 gfd
· RO permeate (SDI < 1)	21–30 gfd

Saturation Limits (Using Antiscalants)[†]

· Langlier Saturation Index (LSI)	<+1.5
· Stiff and Davis Saturation Index (SDSI)	<+0.5
· CaSO ₄	230% saturation
· SrSO ₄	800% saturation
· BaSO ₄	6,000% saturation
· SiO ₂	100% saturation

[†]The above saturation limits are typically accepted by proprietary antiscalant manufacturers. It is the user's responsibility to ensure proper chemical(s) and concentration are dosed ahead of the membrane system to prevent scale formation anywhere within the membrane system. Membrane elements fouled or damaged due to scale formation are not covered by the limited warranty.

GENERAL HANDLING PROCEDURES

- Elements contained in the boxes must be kept dry at room temperature (7–32°C; 40–95°F) and should not be stored in direct sunlight. If the polyethylene bag is damaged, a new preservative solution (sodium bisulfite) must be added and air-tight sealed to prevent drying and biological growth.
- Permeate from the first hour of operation should be discarded to flush out the preservative solution.
- Elements should be immersed in a preservative solution during storage, shipping and system shutdowns to prevent biological growth and freezing. The standard storage solution contains 1% by weight sodium bisulfite or sodium metabisulfite (food grade). For short term storage (i.e. one week or less) 1% by weight sodium metabisulfite solution is adequate for preventing biological growth.
- Keep elements moist at all times after initial wetting.
- Avoid excessive pressure and flow spikes.
- Only use chemicals compatible with the membrane elements and components. Use of such chemicals may void the element limited warranty.
- Permeate pressure must always be equal or less than the feed/concentrate pressure. Damage caused by permeate back pressure voids the element limited warranty.

CSM 8" Membranes



Ref. MCRE8040-BLR440

RE8040-BLR440

Low pressure grade RO element for brackish water

CSM

SPECIFICATIONS:

General Features	Permeate flow rate:	9,900 GPD (37.4 m ³ /day)
	Nominal salt rejection:	99.6%
	Effective membrane area:	440 ft ² (40.9 m ²)

1. The stated product performance is based on data taken after 30 minutes of operation at the following test conditions:

- 1,500 mg/L NaCl solution at 150 psig (1.0 MPa) applied pressure
- 15% recovery
- 77 °F (25 °C)
- pH 6.5–7.0

2. Minimum salt rejection is 99.5%.

3. Permeate flow rate for each element may vary but will be no more than 15%.

4. All elements are vacuum sealed in a polyethylene bag containing 1.0% SBS (sodium bisulfite) solution and individually packaged in a cardboard box.

Membrane type:	Thin-Film Composite
Membrane material:	Polyamide (PA)
Element configuration:	Spiral-Wound, FRP Wrapping

Dimensions and Weight

Model Name	A	B	C	Weight	Part Number	
					Inter-connector	Brine Seal
RE8040-BLR440	40.0 inch (1,016 mm)	8.0 inch (201 mm)	1.12 inch (28 mm)	15 kg	40000308	40000309

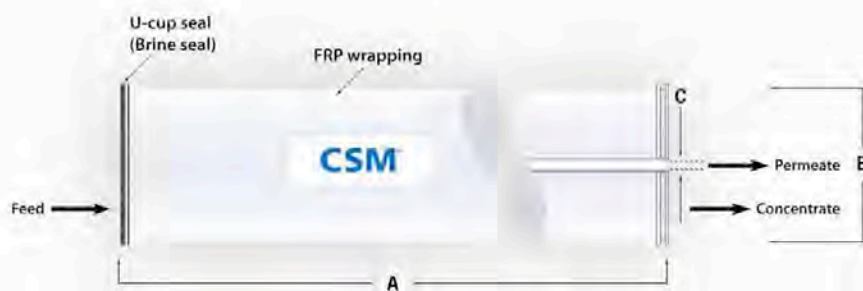

1. Each membrane element supplied with one brine seal, one interconnector (coupler) and four o-rings.
2. All RE8040 elements fit nominal 8.0 inch (201 mm) I.D. pressure vessels.
3. RE8040-BLR440 element can be also made with a 1.5 inch (38mm) diameter central pipe.

The information provided in this document is solely for informative purposes. It is the user's responsibility to ensure the appropriate usage of this product. Woongin Chemical assumes no obligation, liability or damages incurred for the misuse of the product or for the information provided in this document. This document does not express or implies any warranty as to the merchantability or fitness of the product.



RE8040-BLR440

Normal low pressure grade RO element for brackish water

CSM[®]

APPLICATION DATA:

Operating Limits

· Max. Pressure Drop / Element	15 psi (0.1 MPa)
· Max. Pressure Drop / 240" Vessel	60 psi (0.41 Mpa)
· Max. Operating Pressure	600 psi (4.14 MPa)
· Max. Feed Flow Rate	75 gpm (17.0 m ³ /hr)
· Min. Concentrate Flow Rate	16 gpm (3.6 m ³ /hr)
· Max. Operating Temperature	113 °F (45 °C)
· Operating pH Range	2.0–11.0
· CIP pH Range	1.0–13.0
· Max. Turbidity	1.0 NTU
· Max. SDI (15 min)	5.0
· Max. Chlorine Concentration	< 0.1 mg/L

Design Guidelines for Various Water Sources

· Wastewater Conventional (SDI < 5)	8–12 gfd
· Wastewater Pretreated by UF/MF (SDI < 3)	10–14 gfd
· Seawater, Open Intake (SDI < 5)	7–10 gfd
· Seawater, Beach Well (SDI < 3)	8–12 gfd
· Surface Water (SDI < 5)	12–16 gfd
· Surface Water (SDI < 3)	13–17 gfd
· Well water (SDI < 3)	13–17 gfd
· RO permeate (SDI < 1)	21–30 gfd

Saturation Limits (Using Antiscalants)[†]

· Langlier Saturation Index (LSI)	<+1.5
· Stiff and Davis Saturation Index (SDSI)	<+0.5
· CaSO ₄	230% saturation
· SrSO ₄	800% saturation
· BaSO ₄	6,000% saturation
· SiO ₂	100% saturation

[†]The above saturation limits are typically accepted by proprietary antiscalant manufacturers. It is the user's responsibility to ensure proper chemical(s) and concentration are dosed ahead of the membrane system to prevent scale formation anywhere within the membrane system. Membrane elements fouled or damaged due to scale formation are not covered by the limited warranty.

GENERAL HANDLING PROCEDURES

- Elements contained in the boxes must be kept dry at room temperature (7–32°C; 40–95°F) and should not be stored in direct sunlight. If the polyethylene bag is damaged, a new preservative solution (sodium bisulfite) must be added and air-tight sealed to prevent drying and biological growth.
- Permeate from the first hour of operation should be discarded to flush out the preservative solution.
- Elements should be immersed in a preservative solution during storage, shipping and system shutdowns to prevent biological growth and freezing. The standard storage solution contains 1% by weight sodium bisulfite or sodium metabisulfite (food grade). For short term storage (i.e. one week or less) 1% by weight sodium metabisulfite solution is adequate for preventing biological growth.
- Keep elements moist at all times after initial wetting.
- Avoid excessive pressure and flow spikes.
- Only use chemicals compatible with the membrane elements and components. Use of such chemicals may void the element limited warranty.
- Permeate pressure must always be equal or less than the feed/concentrate pressure. Damage caused by permeate back pressure voids the element limited warranty.



Ref. MCRE8040-BLF

RE8040-BLF

Ultra-low pressure RO element for low TDS water

CSM[®]

SPECIFICATIONS:

General Features	Permeate flow rate:	11,500 GPD (43.5 m ³ /day)
	Nominal salt rejection:	99.2%
	Effective membrane area:	400 ft ² (37.2 m ²)

- The stated product performance is based on data taken after 30 minutes of operation at the following test conditions:
 - 500 mg/L NaCl solution at 100 psig (0.7 MPa) applied pressure
 - 15% recovery
 - 77 °F (25 °C)
 - pH 6.5–7.0
- Minimum salt rejection is 99.0%.
- Permeate flow rate for each element may vary but will be no more than 10%.
- All elements are vacuum sealed in a polyethylene bag containing 1.0% SBS (sodium bisulfite) solution and individually packaged in a cardboard box.

Membrane type:	Thin-Film Composite
Membrane material:	Polyamide (PA)
Element configuration:	Spiral-Wound, FRP Wrapping

Dimensions **A** = 40.0 inch (1,016 mm) **B** = 8.0 inch (201 mm) **C** = 1.12 inch (28 mm)



- Each membrane element supplied with one brine seal, one interconnector (coupler) and four o-rings.
- All RE8040 elements fit nominal 8.0 inch (201 mm) I.D. pressure vessels.

The information provided in this document is solely for informative purposes. It is the user's responsibility to ensure the appropriate usage of this product. Woongjin Chemical assumes no obligation, liability or damages incurred for the misuse of the product or for the information provided in this document. This document does not express or imply any warranty as to the merchantability or fitness of the product.



RE8040-BLF

Ultra-low pressure RO element for low TDS water

CSM[®]

APPLICATION DATA:

Operating Limits

· Max. Pressure Drop / Element	15 psi (0.1 MPa)
· Max. Pressure Drop / 240" Vessel	60 psi (0.41 Mpa)
· Max. Operating Pressure	600 psi (4.14 MPa)
· Max. Feed Flow Rate	75 gpm (17.0 m ³ /hr)
· Min. Concentrate Flow Rate	16 gpm (3.6 m ³ /hr)
· Max. Operating Temperature	113 °F (45 °C)
· Operating pH Range	2.0–11.0
· CIP pH Range	1.0–13.0
· Max. Turbidity	1.0 NTU
· Max. SDI (15 min)	5.0
· Max. Chlorine Concentration	< 0.1 mg/L

Design Guidelines for Various Water Sources

· Wastewater Conventional (SDI < 5)	8–12 gfd
· Wastewater Pretreated by UF/MF (SDI < 3)	10–14 gfd
· Seawater, Open Intake (SDI < 5)	7–10 gfd
· Seawater, Beach Well (SDI < 3)	8–12 gfd
· Surface Water (SDI < 5)	12–16 gfd
· Surface Water (SDI < 3)	13–17 gfd
· Well water (SDI < 3)	13–17 gfd
· RO permeate (SDI < 1)	21–30 gfd

Saturation Limits (Using Antiscalants)[†]

· Langlier Saturation Index (LSI)	<+1.5
· Stiff and Davis Saturation Index (SDSI)	<+0.5
· CaSO ₄	230% saturation
· SrSO ₄	800% saturation
· BaSO ₄	6,000% saturation
· SiO ₂	100% saturation

[†]The above saturation limits are typically accepted by proprietary antiscalant manufacturers. It is the user's responsibility to ensure proper chemical(s) and concentration are dosed ahead of the membrane system to prevent scale formation anywhere within the membrane system. Membrane elements fouled or damaged due to scale formation are not covered by the limited warranty.

GENERAL HANDLING PROCEDURES

- Elements contained in the boxes must be kept dry at room temperature (7–32°C; 40–95°F) and should not be stored in direct sunlight. If the polyethylene bag is damaged, a new preservative solution (sodium bisulfite) must be added and air-tight sealed to prevent drying and biological growth.
- Permeate from the first hour of operation should be discarded to flush out the preservative solution.
- Elements should be immersed in a preservative solution during storage, shipping and system shutdowns to prevent biological growth and freezing. The standard storage solution contains 1% by weight sodium bisulfite or sodium metabisulfite (food grade). For short term storage (i.e. one week or less) 1% by weight sodium metabisulfite solution is adequate for preventing biological growth.
- Keep elements moist at all times after initial wetting.
- Avoid excessive pressure and flow spikes.
- Only use chemicals compatible with the membrane elements and components. Use of such chemicals may void the element limited warranty.
- Permeate pressure must always be equal or less than the feed/concentrate pressure. Damage caused by permeate back pressure voids the element limited warranty.

CSM 8" Membranes



Ref. MCRE8040-BLF440

RE8040-BLF440

Ultra-low pressure RO element for low TDS water

CSM[®]

SPECIFICATIONS:

General Features	Permeate flow rate:	12,650 GPD (37.4 m ³ /day)
	Nominal salt rejection:	99.2%
	Effective membrane area:	440 ft ² (40.9 m ²)

1. The stated product performance is based on data taken after 30 minutes of operation at the following test conditions:

- 500 mg/L NaCl solution at 100 psig (0.7 MPa) applied pressure
- 15% recovery
- 77 °F (25 °C)
- pH 6.5–7.0

2. Minimum salt rejection is 99.0%.

3. Permeate flow rate for each element may vary but will be no more than 15%.

4. All elements are vacuum sealed in a polyethylene bag containing 1.0% SBS (sodium bisulfite) solution and individually packaged in a cardboard box.

Membrane type:	Thin-Film Composite
Membrane material:	Polyamide (PA)
Element configuration:	Spiral-Wound, FRP Wrapping

Dimensions and Weight

Model Name	A	B	C	Weight	Part Number	
					Inter-connector	Brine Seal
RE8040-BLF440	40.0 inch (1,016 mm)	8.0 inch (201 mm)	1.12 inch (28 mm)	15 kg	40000308	40000309

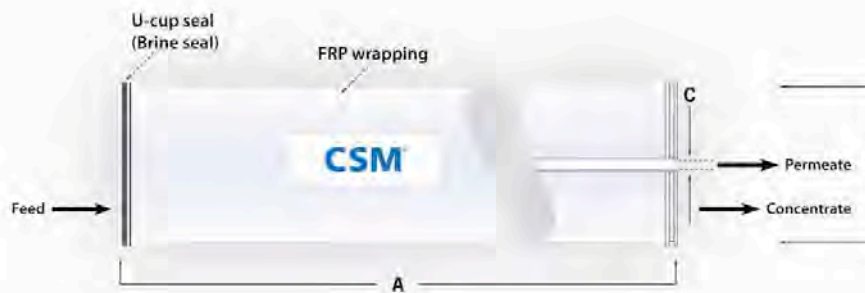

1. Each membrane element supplied with one brine seal, one interconnector (coupler) and four o-rings.
2. All RE8040 elements fit nominal 8.0 inch (201 mm) I.D. pressure vessels.
3. RE8040-BLF440 element can be also made with a 1.5 inch (38mm) diameter central pipe.

The information provided in this document is solely for informative purposes. It is the user's responsibility to ensure the appropriate usage of this product. Woongin Chemical assumes no obligation, liability or damages incurred for the misuse of the product or for the information provided in this document. This document does not express or implies any warranty as to the merchantability or fitness of the product.



RE8040-BLF440

Ultra-low pressure RO element for low TDS water

CSM[®]

APPLICATION DATA:

Operating Limits

· Max. Pressure Drop / Element	15 psi (0.1 MPa)
· Max. Pressure Drop / 240" Vessel	60 psi (0.41 MPa)
· Max. Operating Pressure	600 psi (4.14 MPa)
· Max. Feed Flow Rate	75 gpm (17.0 m ³ /hr)
· Min. Concentrate Flow Rate	16 gpm (3.6 m ³ /hr)
· Max. Operating Temperature	113 °F (45 °C)
· Operating pH Range	2.0–11.0
· CIP pH Range	1.0–13.0
· Max. Turbidity	1.0 NTU
· Max. SDI (15 min)	5.0
· Max. Chlorine Concentration	< 0.1 mg/L

Design Guidelines for Various Water Sources

· Wastewater Conventional (SDI < 5)	8–12 gfd
· Wastewater Pretreated by UF/MF (SDI < 3)	10–14 gfd
· Seawater, Open Intake (SDI < 5)	7–10 gfd
· Seawater, Beach Well (SDI < 3)	8–12 gfd
· Surface Water (SDI < 5)	12–16 gfd
· Surface Water (SDI < 3)	13–17 gfd
· Well water (SDI < 3)	13–17 gfd
· RO permeate (SDI < 1)	21–30 gfd

Saturation Limits (Using Antiscalants)[†]

· Langlier Saturation Index (LSI)	<+1.5
· Stiff and Davis Saturation Index (SDSI)	<+0.5
· CaSO ₄	230% saturation
· SrSO ₄	800% saturation
· BaSO ₄	6,000% saturation
· SiO ₂	100% saturation

[†]The above saturation limits are typically accepted by proprietary antiscalant manufacturers. It is the user's responsibility to ensure proper chemical(s) and concentration are dosed ahead of the membrane system to prevent scale formation anywhere within the membrane system. Membrane elements fouled or damaged due to scale formation are not covered by the limited warranty.

GENERAL HANDLING PROCEDURES

- Elements contained in the boxes must be kept dry at room temperature (7–32°C; 40–95°F) and should not be stored in direct sunlight. If the polyethylene bag is damaged, a new preservative solution (sodium bisulfite) must be added and air-tight sealed to prevent drying and biological growth.
- Permeate from the first hour of operation should be discarded to flush out the preservative solution.
- Elements should be immersed in a preservative solution during storage, shipping and system shutdowns to prevent biological growth and freezing. The standard storage solution contains 1% by weight sodium bisulfite or sodium metabisulfite (food grade). For short term storage (i.e. one week or less) 1% by weight sodium metabisulfite solution is adequate for preventing biological growth.
- Keep elements moist at all times after initial wetting.
- Avoid excessive pressure and flow spikes.
- Only use chemicals compatible with the membrane elements and components. Use of such chemicals may void the element limited warranty.
- Permeate pressure must always be equal or less than the feed/concentrate pressure. Damage caused by permeate back pressure voids the element limited warranty.

TORAY 8" Membranes



Ref. MTMH20A-400C

TORAY
Innovation by Chemistry

Ultra low pressure BWRO TMHA (C)

Type	Diameter Inch	Membrane Area ft ² (m ²)	Salt Rejection %	Product Flow Rate gpd(m ³ / d)	Feed Spacer Thickness mil
TMH20A-400C	8"	400(37)	99.3	11,000(41.6)	34

1. Membrane Type		Cross Linked Fully Aromatic Polyamide Composite
2. Test Conditions	Feed Water Pressure Feed Water Temperature Feed Water Concentration Recovery Rate Feed Water pH	100 psi(0.69MPa) 77° F(25°C) 500 mg/l Nacl 15% 7
3. Minimum Salt Rejection		99.0%
4. Minimum Product Flow Rate		8,800gpd(33.3m ³ /d)

Dimensions

All dimensions shown in Inches (millimeter).

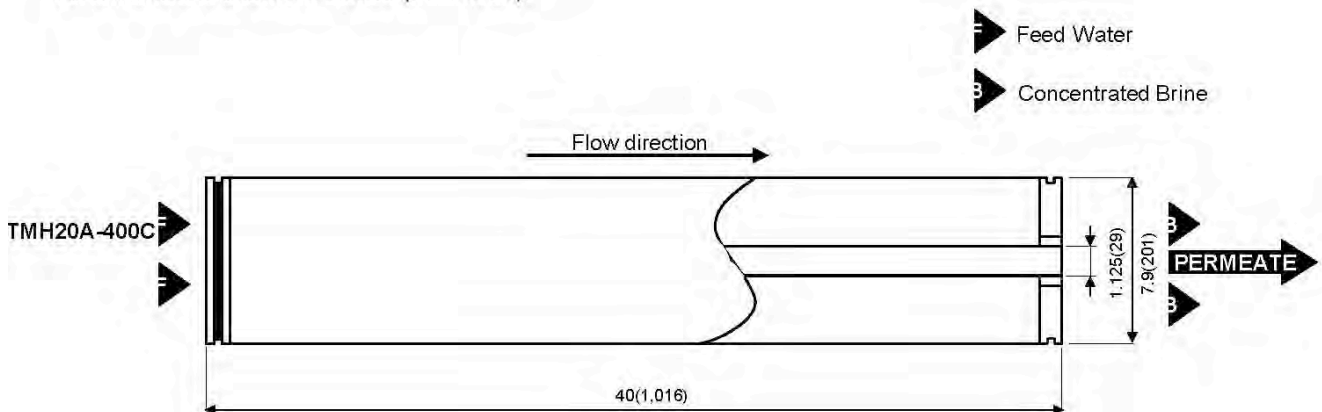



Operating Limits

Maximum Operating Pressure	365psi (2.5 MPa)
Maximum Feed Water Temperature	113° F (45°C)
Maximum Feed Water SDI15	5
Feed Water Chlorine Concentration	Not Detectable
Feed Water pH Range, Continuous Operation	2-11
Feed Water pH Range, Chemical Cleaning	1-12
Maximum Pressure Drop per Element	15 psi (0.10 MPa)
Maximum Pressure Drop per Vessel	50 psi (0.34 MPa)

Operating Information

1. For the recommended design range, please consult the latest Toray technical bulletin, design guide lines, computer design program, and/ or call an application specialist. If the operating limits given in this Product Information Bulletin are not strictly followed, the Limited Warranty will be null and void.
2. All elements are wet tested, treated with a 1% by weight percent sodium bisulfite storage solution, and then vacuum packed in oxygen barrier bags, or treated with tested feed water solution, and then vacuum packed in oxygen barrier bags with deoxidant inside. To prevent biological growth during short term storage, shipment, or system shutdown, it is recommended that Toray elements be immersed in a protective solution containing 500 - 1,000 ppm of sodium bisulfite (food grade) dissolved in permeate.
3. The presence of free chlorine and other oxidizing agents under certain conditions, such as heavy metals which acts as oxidation catalyst in the feed water will cause unexpected oxidation of the membrane. It is strongly recommended to remove these oxidizing agents contained in feed water before operating RO system.
4. Permeate from the first hour of operation shall be discarded.
5. The customer is fully responsible for the effects of chemicals that are incompatible with the elements. Their use will void the element Limited Warranty.

Notice

1. Toray accepts no responsibility for results obtained by the application of this information or the safety or suitability of Toray's products, either alone or in combination with other products. Users are advised to make their own tests to determine the safety and suitability of each product combination for their own purposes.
2. All data may change without prior notice, due to technical modifications or production changes.

TORAY 8" Membranes



Ref. MTMG20D-400

TORAY
Innovation by Chemistry

Ultra low pressure BWRO, enhanced chemical tolerance

T M G (D)

Type	Diameter Inch	Membrane Area ft ² (m ²)	Salt Rejection %	Product Flow Rate gpd(m ³ / d)	Feed Spacer Thickness mil
TMG20D-400	8"	400(37)	99.7	12,100(45.8)	34

1. Membrane Type		Cross Linked Fully Aromatic Polyamide Composite
2. Test Conditions	Feed Water Pressure Feed Water Temperature Feed Water Concentration Recovery Rate Feed Water pH	150 psi(1.03MPa) 77° F(25°C) 2000 mg/l Nacl 15% 7
3. Minimum Salt Rejection		99.5%
4. Minimum Product Flow Rate		10,300gpd(39.0m ³ /d)

Dimensions

All dimensions shown in Inches (millimeter).

F Feed Water
B Concentrated Brine

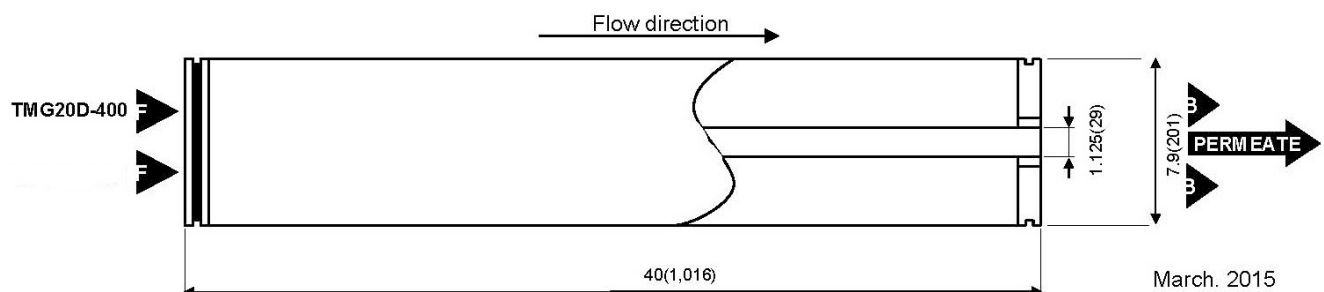



Operating Limits

Maximum Operating Pressure	_____	365psi (2.5 MPa)
Maximum Feed Water Temperature	_____	113° F (45°C)
Maximum Feed Water SDI15	_____	5
Feed Water Chlorine Concentration	_____ ^{*See below 3 of Operating Information}	< 0.1ppm
Feed Water pH Range, Continuous Operation	_____	2-11
Feed Water pH Range, Chemical Cleaning	_____	1-13
Maximum Pressure Drop per Element	_____	15psi (0.10 MPa)
Maximum Pressure Drop per Vessel	_____	50psi (0.34 MPa)

Operating Information

1. For the recommended design range, please consult the latest Toray technical bulletin, design guide lines, computer design program, and/ or call an application specialist. If the operating limits given in this Product Information Bulletin are not strictly followed, the Limited Warranty will be null and void.
 2. All elements are wet tested, treated with a 1% by weight percent sodium bisulfite storage solution, and then vacuum packed in oxygen barrier bags, or treated with tested feed water solution, and then vacuum packed in oxygen barrier bags with deoxidant inside. To prevent biological growth during short term storage, shipment, or system shutdown, it is recommended that Toray elements be immersed in a protective solution containing 500 - 1,000 ppm of sodium bisulfite (food grade) dissolved in permeate.
 3. The presence of free chlorine and other oxidizing agents under certain conditions, such as heavy metals which acts as oxidation catalyst in the feed water will cause unexpected oxidation of the membrane. Since oxidation damage is not covered under warranty, it is strongly recommended to remove these oxidizing agents contained in feed water before operating RO system.
 4. Permeate from the first hour of operation shall be discarded.
 5. The customer is fully responsible for the effects of chemicals that are incompatible with the elements. Their use will void the element Limited Warranty.
-

Notice

1. Toray accepts no responsibility for results obtained by the application of this information or the safety or suitability of Toray's products, either alone or in combination with other products. Users are advised to make their own tests to determine the safety and suitability of each product combination for their own purposes.
2. All data may change without prior notice, due to technical modifications or production changes.



Ref. MCRE8040-BN

RE8040-BN

Low pressure grade RO element with thick feed spacer for brackish water

CSM[®]

SPECIFICATIONS:

General Features	Permeate flow rate:	9,500 GPD (36.0 m ³ /day)
	Nominal salt rejection:	99.7%
	Effective membrane area:	365 ft ² (33.9 m ²)

1. The stated product performance is based on data taken after 30 minutes of operation at the following test conditions:

- 2,000 mg/L NaCl solution at 225 psig (1.5 MPa) applied pressure
- 15% recovery
- 77 °F (25 °C)
- pH 6.5–7.0

2. Minimum salt rejection is 99.4%.

3. Permeate flow rate for each element may vary but will be no more than 10%.

4. All elements are vacuum sealed in a polyethylene bag containing 1.0% SBS (sodium bisulfite) solution and individually packaged in a cardboard box.

Membrane type:	Thin-Film Composite
Membrane material:	Polyamide (PA)
Element configuration:	Spiral-Wound, FRP Wrapping

Dimensions **A** = 40.0 inch (1,016 mm) **B** = 8.0 inch (201 mm) **C** = 1.12 inch (28 mm)



1. Each membrane element supplied with one brine seal, one interconnector (coupler) and four o-rings.
2. All RE8040 elements fit nominal 8.0 inch (201 mm) I.D. pressure vessels.

The information provided in this document is solely for informative purposes. It is the user's responsibility to ensure the appropriate usage of this product. Woongjin Chemical assumes no obligation, liability or damages incurred for the misuse of the product or for the information provided in this document. This document does not express or implies any warranty as to the merchantability or fitness of the product.



RE8040-BN

Low pressure grade RO element with thick feed spacer for brackish water

CSM[®]

APPLICATION DATA:

Operating Limits

· Max. Pressure Drop / Element	15 psi (0.1 MPa)
· Max. Pressure Drop / 240" Vessel	60 psi (0.41 MPa)
· Max. Operating Pressure	600 psi (4.14 MPa)
· Max. Feed Flow Rate	75 gpm (17.0 m ³ /hr)
· Min. Concentrate Flow Rate	16 gpm (3.6 m ³ /hr)
· Max. Operating Temperature	113 °F (45 °C)
· Operating pH Range	2.0–11.0
· CIP pH Range	1.0–13.0
· Max. Turbidity	1.0 NTU
· Max. SDI (15 min)	5.0
· Max. Chlorine Concentration	< 0.1 mg/L

Design Guidelines for Various Water Sources

· Wastewater Conventional (SDI < 5)	8–12 gfd
· Wastewater Pretreated by UF/MF (SDI < 3)	10–14 gfd
· Seawater, Open Intake (SDI < 5)	7–10 gfd
· Seawater, Beach Well (SDI < 3)	8–12 gfd
· Surface Water (SDI < 5)	12–16 gfd
· Surface Water (SDI < 3)	13–17 gfd
· Well water (SDI < 3)	13–17 gfd
· RO permeate (SDI < 1)	21–30 gfd

Saturation Limits (Using Antiscalants)[†]

· Langlier Saturation Index (LSI)	<+1.5
· Stiff and Davis Saturation Index (SDSI)	<+0.5
· CaSO ₄	230% saturation
· SrSO ₄	800% saturation
· BaSO ₄	6,000% saturation
· SiO ₂	100% saturation

[†]The above saturation limits are typically accepted by proprietary antiscalant manufacturers. It is the user's responsibility to ensure proper chemical(s) and concentration are dosed ahead of the membrane system to prevent scale formation anywhere within the membrane system. Membrane elements fouled or damaged due to scale formation are not covered by the limited warranty.

GENERAL HANDLING PROCEDURES

- Elements contained in the boxes must be kept dry at room temperature (7–32°C; 40–95°F) and should not be stored in direct sunlight. If the polyethylene bag is damaged, a new preservative solution (sodium bisulfite) must be added and air-tight sealed to prevent drying and biological growth.
- Permeate from the first hour of operation should be discarded to flush out the preservative solution.
- Elements should be immersed in a preservative solution during storage, shipping and system shutdowns to prevent biological growth and freezing. The standard storage solution contains 1% by weight sodium bisulfite or sodium metabisulfite (food grade). For short term storage (i.e. one week or less) 1% by weight sodium metabisulfite solution is adequate for preventing biological growth.
- Keep elements moist at all times after initial wetting.
- Avoid excessive pressure and flow spikes.
- Only use chemicals compatible with the membrane elements and components. Use of such chemicals may void the element limited warranty.
- Permeate pressure must always be equal or less than the feed/concentrate pressure. Damage caused by permeate back pressure voids the element limited warranty.



Ref. MCRE8040-BE

RE8040-BE

High productivity RO element for brackish water

CSM[®]

SPECIFICATIONS:

General Features	Permeate flow rate:	10,500 GPD (39.7 m ³ /day)
	Nominal salt rejection:	99.7%
	Effective membrane area:	400 ft ² (37.2 m ²)

1. The stated product performance is based on data taken after 30 minutes of operation at the following test conditions:

- 2,000 mg/L NaCl solution at 225 psig (1.5 MPa) applied pressure
- 15% recovery
- 77 °F (25 °C)
- pH 6.5–7.0

2. Minimum salt rejection is 99.4%.

3. Permeate flow rate for each element may vary but will be no more than 10%.

4. All elements are vacuum sealed in a polyethylene bag containing 1.0% SBS (sodium bisulfite) solution and individually packaged in a cardboard box.

Membrane type:	Thin-Film Composite
Membrane material:	Polyamide (PA)
Element configuration:	Spiral-Wound, FRP Wrapping

Dimensions **A** = 40.0 inch (1,016 mm) **B** = 8.0 inch (201 mm) **C** = 1.12 inch (28 mm)



1. Each membrane element supplied with one brine seal, one interconnector (coupler) and four o-rings.
2. All RE8040 elements fit nominal 8.0 inch (201 mm) I.D. pressure vessels.

The information provided in this document is solely for informative purposes. It is the user's responsibility to ensure the appropriate usage of this product. Woongjin Chemical assumes no obligation, liability or damages incurred for the misuse of the product or for the information provided in this document. This document does not express or implies any warranty as to the merchantability or fitness of the product.



RE8040-BE

High productivity RO element for brackish water

CSM[®]

APPLICATION DATA:

Operating Limits

· Max. Pressure Drop / Element	15 psi (0.1 MPa)
· Max. Pressure Drop / 240" Vessel	60 psi (0.41 MPa)
· Max. Operating Pressure	600 psi (4.14 MPa)
· Max. Feed Flow Rate	75 gpm (17.0 m ³ /hr)
· Min. Concentrate Flow Rate	16 gpm (3.6 m ³ /hr)
· Max. Operating Temperature	113 °F (45 °C)
· Operating pH Range	2.0–11.0
· CIP pH Range	1.0–13.0
· Max. Turbidity	1.0 NTU
· Max. SDI (15 min)	5.0
· Max. Chlorine Concentration	< 0.1 mg/L

Design Guidelines for Various Water Sources

· Wastewater Conventional (SDI < 5)	8–12 gfd
· Wastewater Pretreated by UF/MF (SDI < 3)	10–14 gfd
· Seawater, Open Intake (SDI < 5)	7–10 gfd
· Seawater, Beach Well (SDI < 3)	8–12 gfd
· Surface Water (SDI < 5)	12–16 gfd
· Surface Water (SDI < 3)	13–17 gfd
· Well water (SDI < 3)	13–17 gfd
· RO permeate (SDI < 1)	21–30 gfd

Saturation Limits (Using Antiscalants)[†]

· Langelier Saturation Index (LSI)	<+1.5
· Stiff and Davis Saturation Index (SDSI)	<+0.5
· CaSO ₄	230% saturation
· SrSO ₄	800% saturation
· BaSO ₄	6,000% saturation
· SiO ₂	100% saturation

[†]The above saturation limits are typically accepted by proprietary antiscalant manufacturers. It is the user's responsibility to ensure proper chemical(s) and concentration are dosed ahead of the membrane system to prevent scale formation anywhere within the membrane system. Membrane elements fouled or damaged due to scale formation are not covered by the limited warranty.

GENERAL HANDLING PROCEDURES

- Elements contained in the boxes must be kept dry at room temperature (7–32°C; 40–95°F) and should not be stored in direct sunlight. If the polyethylene bag is damaged, a new preservative solution (sodium bisulfite) must be added and air-tight sealed to prevent drying and biological growth.
- Permeate from the first hour of operation should be discarded to flush out the preservative solution.
- Elements should be immersed in a preservative solution during storage, shipping and system shutdowns to prevent biological growth and freezing. The standard storage solution contains 1% by weight sodium bisulfite or sodium metabisulfite (food grade). For short term storage (i.e. one week or less) 1% by weight sodium metabisulfite solution is adequate for preventing biological growth.
- Keep elements moist at all times after initial wetting.
- Avoid excessive pressure and flow spikes.
- Only use chemicals compatible with the membrane elements and components. Use of such chemicals may void the element limited warranty.
- Permeate pressure must always be equal or less than the feed/concentrate pressure. Damage caused by permeate back pressure voids the element limited warranty.

CSM 8" Membranes



Ref. MCRE8040-BE440

RE8040-BE440

High productivity RO element with extended area for brackish water

CSM

SPECIFICATIONS:

General Features	Permeate flow rate:	11,500 GPD (43.5 m ³ /day)
	Nominal salt rejection:	99.7%
	Effective membrane area:	440 ft ² (40.9 m ²)

1. The stated product performance is based on data taken after 30 minutes of operation at the following test conditions:

- 2,000 mg/L NaCl solution at 225 psig (1.5 MPa) applied pressure
- 15% recovery
- 77 °F (25 °C)
- pH 6.5–7.0

2. Minimum salt rejection is 99.4%.

3. Permeate flow rate for each element may vary but will be no more than 15%.

4. All elements are vacuum sealed in a polyethylene bag containing 1.0% SBS (sodium bisulfite) solution and individually packaged in a cardboard box.

5. CSM BE440 elements are made equivalent to BN and BE elements but produces more permeate flow due to its extended membrane area.

Membrane type:	Thin-Film Composite
Membrane material:	Polyamide (PA)
Element configuration:	Spiral-Wound, FRP Wrapping

Dimensions and Weight

Model Name	A	B	C	Weight	Part Number	
					Inter-connector	Brine Seal
RE8040-BE440	40.0 inch (1,016 mm)	8.0 inch (201 mm)	1.12 inch (28 mm)	15 kg	40000308	40000309

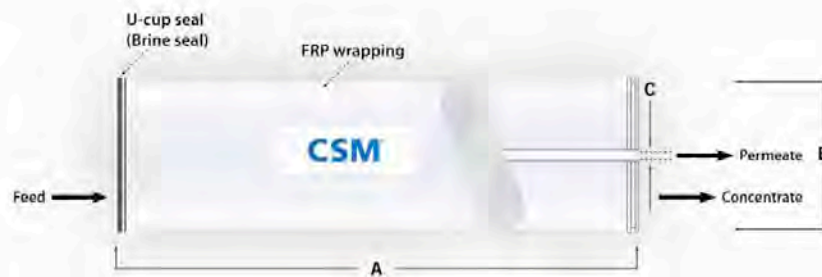

1. Each membrane element supplied with one brine seal, one interconnector (coupler) and four o-rings.
2. All RE8040 elements fit nominal 8.0 inch (201 mm) I.D. pressure vessels.
3. RE8040-BE440 element can be also made with a 1.5 inch (38mm) diameter central pipe.

The information provided in this document is solely for informative purposes. It is the user's responsibility to ensure the appropriate usage of this product. Woongjin Chemical assumes no obligation, liability or damages incurred for the misuse of the product or for the information provided in this document. This document does not express or imply any warranty as to the merchantability or fitness of the product.



RE8040-BE440

High productivity RO element with extended area for brackish water

APPLICATION DATA:

Operating Limits

· Max. Pressure Drop / Element	15 psi (0.1 MPa)
· Max. Pressure Drop / 240" Vessel	60 psi (0.41 MPa)
· Max. Operating Pressure	600 psi (4.14 MPa)
· Max. Feed Flow Rate	75 gpm (17.0 m ³ /hr)
· Min. Concentrate Flow Rate	16 gpm (3.6 m ³ /hr)
· Max. Operating Temperature	113 °F (45 °C)
· Operating pH Range	2.0–11.0
· CIP pH Range	1.0–13.0
· Max. Turbidity	1.0 NTU
· Max. SDI (15 min)	5.0
· Max. Chlorine Concentration	< 0.1 mg/L

Design Guidelines for Various Water Sources

· Wastewater Conventional (SDI < 5)	8–12 gfd
· Wastewater Pretreated by UF/MF (SDI < 3)	10–14 gfd
· Seawater, Open Intake (SDI < 5)	7–10 gfd
· Seawater, Beach Well (SDI < 3)	8–12 gfd
· Surface Water (SDI < 5)	12–16 gfd
· Surface Water (SDI < 3)	13–17 gfd
· Well water (SDI < 3)	13–17 gfd
· RO permeate (SDI < 1)	21–30 gfd

Saturation Limits (Using Antiscalants)[†]

· Langelier Saturation Index (LSI)	<+1.5
· Stiff and Davis Saturation Index (SDSI)	<+0.5
· CaSO ₄	230% saturation
· SrSO ₄	800% saturation
· BaSO ₄	6,000% saturation
· SiO ₂	100% saturation

[†]The above saturation limits are typically accepted by proprietary antiscalant manufacturers. It is the user's responsibility to ensure proper chemical(s) and concentration are dosed ahead of the membrane system to prevent scale formation anywhere within the membrane system. Membrane elements fouled or damaged due to scale formation are not covered by the limited warranty.

GENERAL HANDLING PROCEDURES

- Elements contained in the boxes must be kept dry at room temperature (7–32°C; 40–95°F) and should not be stored in direct sunlight. If the polyethylene bag is damaged, a new preservative solution (sodium bisulfite) must be added and air-tight sealed to prevent drying and biological growth.
- Permeate from the first hour of operation should be discarded to flush out the preservative solution.
- Elements should be immersed in a preservative solution during storage, shipping and system shutdowns to prevent biological growth and freezing. The standard storage solution contains 1% by weight sodium bisulfite or sodium metabisulfite (food grade). For short term storage (i.e. one week or less) 1% by weight sodium metabisulfite solution is adequate for preventing biological growth.
- Keep elements moist at all times after initial wetting.
- Avoid excessive pressure and flow spikes.
- Only use chemicals compatible with the membrane elements and components. Use of such chemicals may void the element limited warranty.
- Permeate pressure must always be equal or less than the feed/concentrate pressure. Damage caused by permeate back pressure voids the element limited warranty.



Ref. MCRE8040-BR

RE8040-BR

Normal grade RO element with thick feed spacer for brackish water

CSM[®]

SPECIFICATIONS:

General Features	Permeate flow rate:	6,000 GPD (22.7 m ³ /day)
	Nominal salt rejection:	99.75%
	Effective membrane area:	380 ft ² (35.3 m ²)

1. The stated product performance is based on data taken after 30 minutes of operation at the following test conditions:

- 2,000 mg/L NaCl solution at 225 psig (1.5 MPa) applied pressure
- 15% recovery
- 77 °F (25 °C)
- pH 6.5–7.0

2. Minimum salt rejection is 99.4%.

3. Permeate flow rate for each element may vary but will be no more than 10%.

4. All elements are vacuum sealed in a polyethylene bag containing 1.0% SBS (sodium bisulfite) solution and individually packaged in a cardboard box.

Membrane type:	Thin-Film Composite
Membrane material:	Polyamide (PA)
Element configuration:	Spiral-Wound, FRP Wrapping

Dimensions **A** = 40.0 inch (1,016 mm) **B** = 8.0 inch (201 mm) **C** = 1.12 inch (28 mm)



1. Each membrane element supplied with one brine seal, one interconnector (coupler) and four o-rings.
2. All RE8040 elements fit nominal 8.0 inch (201 mm) I.D. pressure vessels.

The information provided in this document is solely for informative purposes. It is the user's responsibility to ensure the appropriate usage of this product. Woongjin Chemical assumes no obligation, liability or damages incurred for the misuse of the product or for the information provided in this document. This document does not express or implies any warranty as to the merchantability or fitness of the product.



RE8040-BR

Normal grade RO element with thick feed spacer for brackish water

CSM[®]

APPLICATION DATA:

Operating Limits

· Max. Pressure Drop / Element	15 psi (0.1 MPa)
· Max. Pressure Drop / 240" Vessel	60 psi (0.41 Mpa)
· Max. Operating Pressure	600 psi (4.14 MPa)
· Max. Feed Flow Rate	75 gpm (17.0 m ³ /hr)
· Min. Concentrate Flow Rate	16 gpm (3.6 m ³ /hr)
· Max. Operating Temperature	113 °F (45 °C)
· Operating pH Range	2.0–11.0
· CIP pH Range	1.0–13.0
· Max. Turbidity	1.0 NTU
· Max. SDI (15 min)	5.0
· Max. Chlorine Concentration	< 0.1 mg/L

Design Guidelines for Various Water Sources

· Wastewater Conventional (SDI < 5)	8–12 gfd
· Wastewater Pretreated by UF/MF (SDI < 3)	10–14 gfd
· Seawater, Open Intake (SDI < 5)	7–10 gfd
· Seawater, Beach Well (SDI < 3)	8–12 gfd
· Surface Water (SDI < 5)	12–16 gfd
· Surface Water (SDI < 3)	13–17 gfd
· Well water (SDI < 3)	13–17 gfd
· RO permeate (SDI < 1)	21–30 gfd

Saturation Limits (Using Antiscalants)[†]

· Langlier Saturation Index (LSI)	<+1.5
· Stiff and Davis Saturation Index (SDSI)	<+0.5
· CaSO ₄	230% saturation
· SrSO ₄	800% saturation
· BaSO ₄	6,000% saturation
· SiO ₂	100% saturation

[†]The above saturation limits are typically accepted by proprietary antiscalant manufacturers. It is the user's responsibility to ensure proper chemical(s) and concentration are dosed ahead of the membrane system to prevent scale formation anywhere within the membrane system. Membrane elements fouled or damaged due to scale formation are not covered by the limited warranty.

GENERAL HANDLING PROCEDURES

- Elements contained in the boxes must be kept dry at room temperature (7–32°C; 40–95°F) and should not be stored in direct sunlight. If the polyethylene bag is damaged, a new preservative solution (sodium bisulfite) must be added and air-tight sealed to prevent drying and biological growth.
- Permeate from the first hour of operation should be discarded to flush out the preservative solution.
- Elements should be immersed in a preservative solution during storage, shipping and system shutdowns to prevent biological growth and freezing. The standard storage solution contains 1% by weight sodium bisulfite or sodium metabisulfite (food grade). For short term storage (i.e. one week or less) 1% by weight sodium metabisulfite solution is adequate for preventing biological growth.
- Keep elements moist at all times after initial wetting.
- Avoid excessive pressure and flow spikes.
- Only use chemicals compatible with the membrane elements and components. Use of such chemicals may void the element limited warranty.
- Permeate pressure must always be equal or less than the feed/concentrate pressure. Damage caused by permeate back pressure voids the element limited warranty.



Ref. MCRE8040-BR400

RE8040-BR400

Normal grade RO element with thick feed spacer for brackish water

CSM[®]

SPECIFICATIONS:

General Features	Permeate flow rate:	6,600 GPD (24.9 m ³ /day)
	Nominal salt rejection:	99.75%
	Effective membrane area:	400 ft ² (37.2 m ²)

1. The stated product performance is based on data taken after 30 minutes of operation at the following test conditions:

- 2,000 mg/L NaCl solution at 225 psig (1.5 MPa) applied pressure
- 15% recovery
- 77 °F (25 °C)
- pH 6.5–7.0

2. Minimum salt rejection is 99.4%.

3. Permeate flow rate for each element may vary but will be no more than 10%.

4. All elements are vacuum sealed in a polyethylene bag containing 1.0% SBS (sodium bisulfite) solution and individually packaged in a cardboard box.

Membrane type:	Thin-Film Composite
Membrane material:	Polyamide (PA)
Element configuration:	Spiral-Wound, FRP Wrapping

Dimensions **A** = 40.0 inch (1,016 mm) **B** = 8.0 inch (201 mm) **C** = 1.12 inch (28 mm)



1. Each membrane element supplied with one brine seal, one interconnector (coupler) and four o-rings.
2. All RE8040 elements fit nominal 8.0 inch (201 mm) I.D. pressure vessels.

The information provided in this document is solely for informative purposes. It is the user's responsibility to ensure the appropriate usage of this product. Woongjin Chemical assumes no obligation, liability or damages incurred for the misuse of the product or for the information provided in this document. This document does not express or implies any warranty as to the merchantability or fitness of the product.



RE8040-BR400

Normal grade RO element with thick feed spacer for brackish water

CSM[®]

APPLICATION DATA:

Operating Limits

· Max. Pressure Drop / Element	15 psi (0.1 MPa)
· Max. Pressure Drop / 240" Vessel	60 psi (0.41 MPa)
· Max. Operating Pressure	600 psi (4.14 MPa)
· Max. Feed Flow Rate	75 gpm (17.0 m ³ /hr)
· Min. Concentrate Flow Rate	16 gpm (3.6 m ³ /hr)
· Max. Operating Temperature	113 °F (45 °C)
· Operating pH Range	2.0–11.0
· CIP pH Range	1.0–13.0
· Max. Turbidity	1.0 NTU
· Max. SDI (15 min)	5.0
· Max. Chlorine Concentration	< 0.1 mg/L

Design Guidelines for Various Water Sources

· Wastewater Conventional (SDI < 5)	8–12 gfd
· Wastewater Pretreated by UF/MF (SDI < 3)	10–14 gfd
· Seawater, Open Intake (SDI < 5)	7–10 gfd
· Seawater, Beach Well (SDI < 3)	8–12 gfd
· Surface Water (SDI < 5)	12–16 gfd
· Surface Water (SDI < 3)	13–17 gfd
· Well water (SDI < 3)	13–17 gfd
· RO permeate (SDI < 1)	21–30 gfd

Saturation Limits (Using Antiscalants)[†]

· Langelier Saturation Index (LSI)	<+1.5
· Stiff and Davis Saturation Index (SDSI)	<+0.5
· CaSO ₄	230% saturation
· SrSO ₄	800% saturation
· BaSO ₄	6,000% saturation
· SiO ₂	100% saturation

[†]The above saturation limits are typically accepted by proprietary antiscalant manufacturers. It is the user's responsibility to ensure proper chemical(s) and concentration are dosed ahead of the membrane system to prevent scale formation anywhere within the membrane system. Membrane elements fouled or damaged due to scale formation are not covered by the limited warranty.

GENERAL HANDLING PROCEDURES

- Elements contained in the boxes must be kept dry at room temperature (7–32°C; 40–95°F) and should not be stored in direct sunlight. If the polyethylene bag is damaged, a new preservative solution (sodium bisulfite) must be added and air-tight sealed to prevent drying and biological growth.
- Permeate from the first hour of operation should be discarded to flush out the preservative solution.
- Elements should be immersed in a preservative solution during storage, shipping and system shutdowns to prevent biological growth and freezing. The standard storage solution contains 1% by weight sodium bisulfite or sodium metabisulfite (food grade). For short term storage (i.e. one week or less) 1% by weight sodium metabisulfite solution is adequate for preventing biological growth.
- Keep elements moist at all times after initial wetting.
- Avoid excessive pressure and flow spikes.
- Only use chemicals compatible with the membrane elements and components. Use of such chemicals may void the element limited warranty.
- Permeate pressure must always be equal or less than the feed/concentrate pressure. Damage caused by permeate back pressure voids the element limited warranty.

TORAY 8" Membranes



Ref. MTM720D-400

TORAY
Innovation by Chemistry

High rejection BWRO, enhanced chemical tolerance

TM700D

Type	Diameter Inch	Membrane Area ft ² (m ²)	Salt Rejection %	Product Flow Rate gpd(m ³ / d)	Feed Spacer Thickness mil
TM720D-400	8"	400(37)	99.8	11,000(41.6)	34

1. Membrane Type		Cross Linked Fully Aromatic Polyamide Composite
2. Test Conditions	Feed Water Pressure Feed Water Temperature Feed Water Concentration Recovery Rate Feed Water pH	225 psi(1.55MPa) 77° F(25°C) 2,000 mg/l NaCl 15% 7
3. Minimum Salt Rejection		99.65%
4. Minimum Product Flow Rate		8,900gpd(33.6m ³ /d)

Dimensions

All dimensions shown in Inches (millimeter).

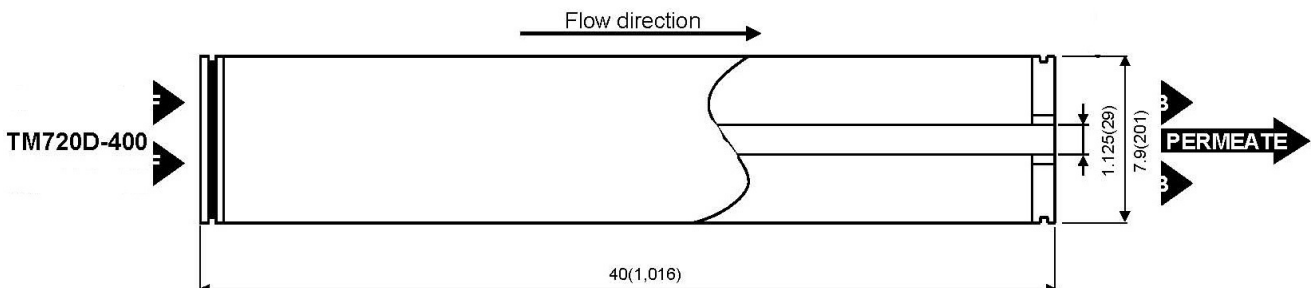
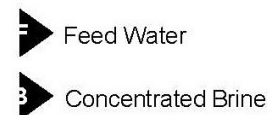



Operating Limits

Maximum Operating Pressure	600psi (4.1 MPa)
Maximum Feed Water Temperature	113° F (45°C)
Maximum Feed Water SDI ₁₅	5
Feed Water Chlorine Concentration <small>*See below 3 of Operating Information</small>	<0.1ppm
Feed Water pH Range, Continuous Operation	2-11
Feed Water pH Range, Chemical Cleaning	1-13
Maximum Pressure Drop per Element	15 psi (0.10 MPa)
Maximum Pressure Drop per Vessel	50 psi (0.34 MPa)

Operating Information

1. For the recommended design range, please consult the latest Toray technical bulletin, design guide lines, computer design program, and/ or call an application specialist. If the operating limits given in this Product Information Bulletin are not strictly followed, the Limited Warranty will be null and void.
 2. All elements are wet tested, treated with a 1% by weight percent sodium bisulfite storage solution, and then vacuum packed in oxygen barrier bags, or treated with tested feed water solution, and then vacuum packed in oxygen barrier bags with deoxidant inside. To prevent biological growth during short term storage, shipment, or system shutdown, it is recommended that Toray elements be immersed in a protective solution containing 500 - 1,000 ppm of sodium bisulfite (food grade) dissolved in permeate.
 3. The presence of free chlorine and other oxidizing agents under certain conditions, such as heavy metals which acts as oxidation catalyst in the feed water will cause unexpected oxidation of the membrane. It is strongly recommended to remove these oxidizing agents contained in feed water before operating RO system.
 4. Permeate from the first hour of operation shall be discarded.
 5. The customer is fully responsible for the effects of chemicals that are incompatible with the elements. Their use will void the element Limited Warranty.
-

Notice

1. Toray accepts no responsibility for results obtained by the application of this information or the safety or suitability of Toray's products, either alone or in combination with other products. Users are advised to make their own tests to determine the safety and suitability of each product combination for their own purposes.
2. All data may change without prior notice, due to technical modifications or production changes.



Ref. MCRE8040-CE

RE8040-CE

Innovative chlorine resistant RO element for prolonged membrane lifetime

CSM[®]

SPECIFICATIONS:

General Features	Permeate flow rate:	8,500 GPD (32.1 m ³ /day)
	Nominal salt rejection:	99.5%
	Effective membrane area:	400 ft ² (37.2 m ²)

1. The stated product performance is based on data taken after 30 minutes of operation at the following test conditions:

- 2,000 mg/L NaCl solution at 225 psig (1.5 MPa) applied pressure
- 15% recovery
- 77 °F (25 °C)
- pH 6.5–7.0

2. Minimum salt rejection is 99.0%

3. Permeate flow rate for each element may vary but will be no more than 10%.

4. All elements are vacuum sealed in a polyethylene bag containing 1.0% SBS (sodium bisulfite) solution and individually packaged in a cardboard box

Membrane type:	Thin-Film Composite
Membrane material:	Polyamide (PA)
Element configuration:	Spiral-Wound, FRP Wrapping

Dimensions **A** = 40.0 inch (1,016 mm) **B** = 8.0 inch (201 mm) **C** = 1.12 inch (28 mm)

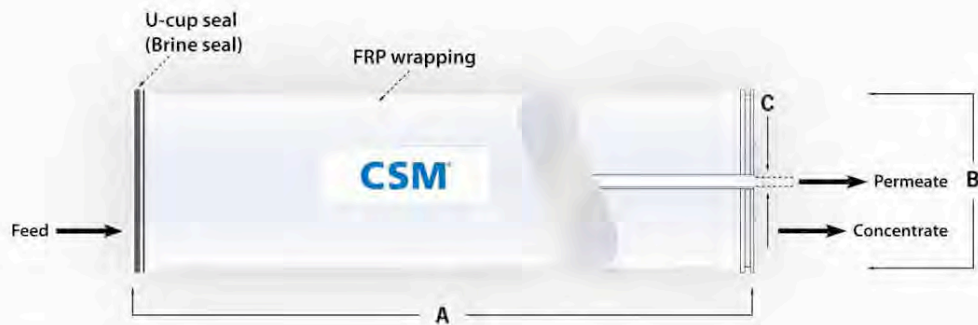

1. Each membrane element supplied with one brine seal, one interconnector (coupler) and four o-rings.
2. All RE8040 elements fit nominal 8.0 inch (201 mm) I.D. pressure vessels.

The information provided in this document is solely for informative purposes. It is the user's responsibility to ensure the appropriate usage of this product. Woongjin Chemical assumes no obligation, liability or damages incurred for the misuse of the product or for the information provided in this document. This document does not express or implies any warranty as to the merchantability or fitness of the product.



RE8040-CE

Innovative chlorine resistant RO element for prolonged membrane lifetime

CSM[®]

APPLICATION DATA:

Operating Limits

· Max. Pressure Drop / Element	15 psi (0.1 MPa)
· Max. Pressure Drop / 240" Vessel	60 psi (0.41 MPa)
· Max. Operating Pressure	600 psi (4.14 MPa)
· Max. Feed Flow Rate	75 gpm (17.0 m ³ /hr)
· Min. Concentrate Flow Rate	16 gpm (3.6 m ³ /hr)
· Max. Operating Temperature	113 °F (45 °C)
· Operating pH Range	2.0–11.0
· CIP pH Range	1.0–13.0
· Max. Turbidity	1.0 NTU
· Max. SDI (15 min)	5.0
· Free Chlorine Tolerance	5,000 ppm hr

Design Guidelines for Various Water Sources

· Wastewater Conventional (SDI < 5)	8–12 gfd
· Wastewater Pretreated by UF/MF (SDI < 3)	10–14 gfd
· Seawater, Open Intake (SDI < 5)	7–10 gfd
· Seawater, Beach Well (SDI < 3)	8–12 gfd
· Surface Water (SDI < 5)	12–16 gfd
· Surface Water (SDI < 3)	13–17 gfd
· Well water (SDI < 3)	13–17 gfd
· RO permeate (SDI < 1)	21–30 gfd

Saturation Limits (Using Antiscalants)[†]

· Langlier Saturation Index (LSI)	<+1.5
· Stiff and Davis Saturation Index (SDSI)	<+0.5
· CaSO ₄	230% saturation
· SrSO ₄	800% saturation
· BaSO ₄	6,000% saturation
· SiO ₂	100% saturation

[†]The above saturation limits are typically accepted by proprietary antiscalant manufacturers. It is the user's responsibility to ensure proper chemical(s) and concentration are dosed ahead of the membrane system to prevent scale formation anywhere within the membrane system. Membrane elements fouled or damaged due to scale formation are not covered by the limited warranty.

GENERAL HANDLING PROCEDURES

- Elements contained in the boxes must be kept dry at room temperature (7–32°C; 40–95°F) and should not be stored in direct sunlight. If the polyethylene bag is damaged, a new preservative solution (sodium bisulfite) must be added and air-tight sealed to prevent drying and biological growth.
- Permeate from the first hour of operation should be discarded to flush out the preservative solution.
- Elements should be immersed in a preservative solution during storage, shipping and system shutdowns to prevent biological growth and freezing. The standard storage solution contains 1% by weight sodium bisulfite or sodium metabisulfite (food grade). For short term storage (i.e. one week or less) 1% by weight sodium metabisulfite solution is adequate for preventing biological growth.
- Keep elements moist at all times after initial wetting.
- Avoid excessive pressure and flow spikes.
- Only use chemicals compatible with the membrane elements and components. Use of such chemicals may void the element limited warranty.
- Permeate pressure must always be equal or less than the feed/concentrate pressure. Damage caused by permeate back pressure voids the element limited warranty.

CSM 8" Membranes



Ref. MCRE8040-FEN34

RE8040-FEⁿ34

Enhanced fouling resistant RO element for brackish water and wastewater reuse

CSM

SPECIFICATIONS:

General Features	Permeate flow rate:	10,500 GPD (39.7 m ³ /day)
	Nominal salt rejection:	99.7%
	Effective membrane area:	400 ft ² (37.2 m ²)
	Feed spacer thickness:	34mil

1. The stated product performance is based on data taken after 30 minutes of operation at the following test conditions:

- 2,000 mg/L NaCl solution at 225 psig (1.5 MPa) applied pressure
- 15% recovery
- 77 °F (25 °C)
- pH 6.5–7.0

2. Minimum salt rejection is 99.4%.

3. Permeate flow rate for each element may vary but will be no more than 15%.

4. All elements are vacuum sealed in a polyethylene bag containing 1.0% SBS (sodium bisulfite) solution and individually packaged in a cardboard box.

Membrane type:	Thin-Film Composite
Membrane material:	Polyamide (PA)
Element configuration:	Spiral-Wound, FRP Wrapping

Dimensions and Weight

Model Name	A	B	C	Weight	Part Number	
					Inter-connector	Brine Seal
RE8040-FEn34	40.0 inch (1,016 mm)	8.0inch (201 mm)	1.12 inch (28 mm)	15 kg	40000308	40000309

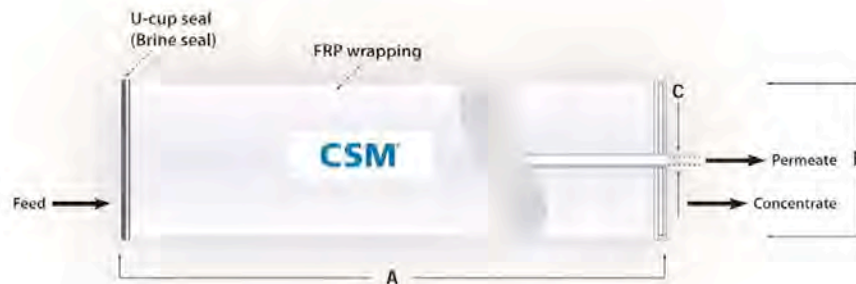

1. Each membrane element supplied with one brine seal, one interconnector (coupler) and four o-rings.
2. All RE8040 elements fit nominal 8.0 inch (201 mm) I.D. pressure vessels.

The information provided in this document is solely for informative purposes. It is the user's responsibility to ensure the appropriate usage of this product. Toray Chemical Korea Inc. assumes no obligation, liability or damages incurred for the misuse of the product or for the information provided in this document. This document does not express or implies any warranty as to the merchantability or fitness of the product.



RE8040-FEⁿ34

Enhanced fouling resistant RO element for brackish water and wastewater reuse

CSM

APPLICATION DATA:

Operating Limits

• Max. Pressure Drop / Element	15 psi (0.1 MPa)
• Max. Pressure Drop / 240" Vessel	60 psi (0.41 MPa)
• Max. Operating Pressure	600 psi (4.14 MPa)
• Max. Feed Flow Rate	75 gpm (17.0 m ³ /hr)
• Min. Concentrate Flow Rate	16 gpm (3.6 m ³ /hr)
• Max. Operating Temperature	113 °F (45 °C)
• Operating pH Range	2.0–11.0
• CIP pH Range	1.0–13.0
• Max. Turbidity	1.0 NTU
• Max. SDI (15 min)	5.0
• Max. Chlorine Concentration	< 0.1 mg/L

Design Guidelines for Various Water Sources

• Wastewater Conventional (SDI < 5)	8–12 gfd
• Wastewater Pretreated by UF/MF (SDI < 3)	10–14 gfd
• Seawater, Open Intake (SDI < 5)	7–10 gfd
• Seawater, Beach Well (SDI < 3)	8–12 gfd
• Surface Water (SDI < 5)	12–16 gfd
• Surface Water (SDI < 3)	13–17 gfd
• Well water (SDI < 3)	13–17 gfd
• RO permeate (SDI < 1)	21–30 gfd

Saturation Limits (Using Antiscalants)[†]

• Langelier Saturation Index (LSI)	<+1.5
• Stiff and Davis Saturation Index (SDSI)	<+0.5
• CaSO ₄	230% saturation
• SrSO ₄	800% saturation
• BaSO ₄	6,000% saturation
• SiO ₂	100% saturation

[†]The above saturation limits are typically accepted by proprietary antiscalant manufacturers. It is the user's responsibility to ensure proper chemical(s) and concentration are dosed ahead of the membrane system to prevent scale formation anywhere within the membrane system. Membrane elements fouled or damaged due to scale formation are not covered by the limited warranty.

GENERAL HANDLING PROCEDURES

- Elements contained in the boxes must be kept dry at room temperature (7–32°C; 40–95°F) and should not be stored in direct sunlight. If the polyethylene bag is damaged, a new preservative solution (sodium bisulfite) must be added and air-tight sealed to prevent drying and biological growth.
- Permeate from the first hour of operation should be discarded to flush out the preservative solution.
- Elements should be immersed in a preservative solution during storage, shipping and system shutdowns to prevent biological growth and freezing. The standard storage solution contains 1% by weight sodium bisulfite or sodium metabisulfite (food grade). For short term storage (i.e. one week or less) 1% by weight sodium metabisulfite solution is adequate for preventing biological growth.
- Keep elements moist at all times after initial wetting.
- Avoid excessive pressure and flow spikes.
- Only use chemicals compatible with the membrane elements and components. Use of such chemicals may void the element limited warranty.
- Permeate pressure must always be equal or less than the feed/concentrate pressure. Damage caused by permeate back pressure voids the element limited warranty.

CSM 8" Membranes



Ref. MCRE8040-FEN

RE8040-FEⁿ

Enhanced fouling resistant RO element for brackish water and wastewater reuse

CSM

SPECIFICATIONS:

General Features	Permeate flow rate:	10,500 GPD (39.7 m ³ /day)
	Nominal salt rejection:	99.7%
	Effective membrane area:	400 ft ² (37.2 m ²)
	Feed spacer thickness:	32 mil

- The stated product performance is based on data taken after 30 minutes of operation at the following test conditions:
 - 2,000 mg/L NaCl solution at 225 psig (1.5 MPa) applied pressure
 - 15% recovery
 - 77 °F (25 °C)
 - pH 6.5–7.0
- Minimum salt rejection is 99.4%.
- Permeate flow rate for each element may vary but will be no more than 15%.
- All elements are vacuum sealed in a polyethylene bag containing 1.0% SBS (sodium bisulfite) solution and individually packaged in a cardboard box.

Membrane type:	Thin-Film Composite
Membrane material:	Polyamide (PA)
Element configuration:	Spiral-Wound, FRP Wrapping

Dimensions and Weight	Model Name	A	B	C	Weight	Part Number	
						Inter-connector	Brine Seal
	RE8040-FEn	40.0 inch (1,016 mm)	8.0inch (201 mm)	1.12 inch (28 mm)	15 kg	40000308	40000309



- Each membrane element supplied with one brine seal, one interconnector (coupler) and four o-rings.
- All RE8040 elements fit nominal 8.0 inch (201 mm) I.D. pressure vessels.

The information provided in this document is solely for informative purposes. It is the user's responsibility to ensure the appropriate usage of this product. Toray Chemical Korea Inc. assumes no obligation, liability or damages incurred for the misuse of the product or for the information provided in this document. This document does not express or imply any warranty as to the merchantability or fitness of the product.



RE8040-FEⁿ

CSM[®]

Enhanced fouling resistant RO element for brackish water and wastewater reuse

APPLICATION DATA:

Operating Limits

· Max. Pressure Drop / Element	15 psi (0.1 MPa)
· Max. Pressure Drop / 240" Vessel	60 psi (0.41 MPa)
· Max. Operating Pressure	600 psi (4.14 MPa)
· Max. Feed Flow Rate	75 gpm (17.0 m ³ /hr)
· Min. Concentrate Flow Rate	16 gpm (3.6 m ³ /hr)
· Max. Operating Temperature	113 °F (45 °C)
· Operating pH Range	2.0–11.0
· CIP pH Range	1.0–13.0
· Max. Turbidity	1.0 NTU
· Max. SDI (15 min)	5.0
· Max. Chlorine Concentration	< 0.1 mg/L

Design Guidelines for Various Water Sources

· Wastewater Conventional (SDI < 5)	8–12 gfd
· Wastewater Pretreated by UF/MF (SDI < 3)	10–14 gfd
· Seawater, Open Intake (SDI < 5)	7–10 gfd
· Seawater, Beach Well (SDI < 3)	8–12 gfd
· Surface Water (SDI < 5)	12–16 gfd
· Surface Water (SDI < 3)	13–17 gfd
· Well water (SDI < 3)	13–17 gfd
· RO permeate (SDI < 1)	21–30 gfd

Saturation Limits (Using Antiscalants)[†]

· Langelier Saturation Index (LSI)	<+1.5
· Stiff and Davis Saturation Index (SDSI)	<+0.5
· CaSO ₄	230% saturation
· SrSO ₄	800% saturation
· BaSO ₄	6,000% saturation
· SiO ₂	100% saturation

[†]The above saturation limits are typically accepted by proprietary antiscalant manufacturers. It is the user's responsibility to ensure proper chemical(s) and concentration are dosed ahead of the membrane system to prevent scale formation anywhere within the membrane system. Membrane elements fouled or damaged due to scale formation are not covered by the limited warranty.

GENERAL HANDLING PROCEDURES

- Elements contained in the boxes must be kept dry at room temperature (7–32°C; 40–95°F) and should not be stored in direct sunlight. If the polyethylene bag is damaged, a new preservative solution (sodium bisulfite) must be added and air-tight sealed to prevent drying and biological growth.
- Permeate from the first hour of operation should be discarded to flush out the preservative solution.
- Elements should be immersed in a preservative solution during storage, shipping and system shutdowns to prevent biological growth and freezing. The standard storage solution contains 1% by weight sodium bisulfite or sodium metabisulfite (food grade). For short term storage (i.e. one week or less) 1% by weight sodium metabisulfite solution is adequate for preventing biological growth.
- Keep elements moist at all times after initial wetting.
- Avoid excessive pressure and flow spikes.
- Only use chemicals compatible with the membrane elements and components. Use of such chemicals may void the element limited warranty.
- Permeate pressure must always be equal or less than the feed/concentrate pressure. Damage caused by permeate back pressure voids the element limited warranty.

CSM 8" Membranes



Ref. MCRE8040-FEN440

RE8040-FEⁿ440

Enhanced fouling resistant RO element for brackish water and wastewater reuse

CSM

SPECIFICATIONS:

General Features	Permeate flow rate:	11,500 GPD (43.5 m ³ /day)
	Nominal salt rejection:	99.7%
	Effective membrane area:	440 ft ² (40.9 m ²)
	Feed spacer thickness:	28mil

1. The stated product performance is based on data taken after 30 minutes of operation at the following test conditions:

- 2,000 mg/L NaCl solution at 225 psig (1.5 MPa) applied pressure
- 15% recovery
- 77 °F (25 °C)
- pH 6.5–7.0

2. Minimum salt rejection is 99.4%.

3. Permeate flow rate for each element may vary but will be no more than 15%.

4. All elements are vacuum sealed in a polyethylene bag containing 1.0% SBS (sodium bisulfite) solution and individually packaged in a cardboard box.

Membrane type:	Thin-Film Composite
Membrane material:	Polyamide (PA)
Element configuration:	Spiral-Wound, FRP Wrapping

Dimensions and Weight

Model Name	A	B	C	Weight	Part Number	
					Inter-connector	Brine Seal
RE8040-FEn440	40.0 inch (1,016 mm)	8.0inch (201 mm)	1.12 inch (28 mm)	15 kg	40000308	40000309

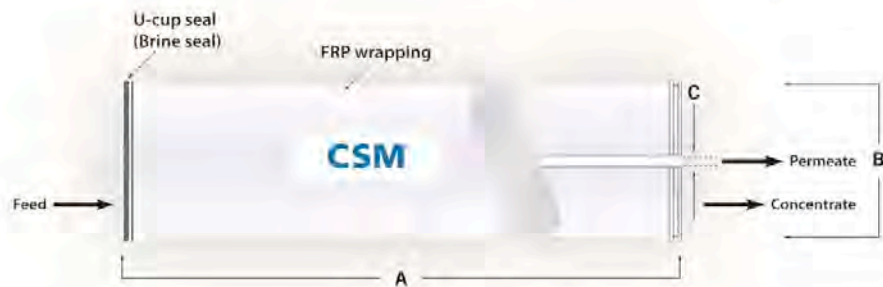

1. Each membrane element supplied with one brine seal, one interconnector (coupler) and four o-rings.
2. All RE8040 elements fit nominal 8.0 inch (201 mm) I.D. pressure vessels.

The information provided in this document is solely for informative purposes. It is the user's responsibility to ensure the appropriate usage of this product. Toray Chemical Korea Inc. assumes no obligation, liability or damages incurred for the misuse of the product or for the information provided in this document. This document does not express or implies any warranty as to the merchantability or fitness of the product.



RE8040-FEⁿ440

Enhanced fouling resistant RO element for brackish water and wastewater reuse

APPLICATION DATA:

Operating Limits

· Max. Pressure Drop / Element	15 psi (0.1 MPa)
· Max. Pressure Drop / 240" Vessel	60 psi (0.41 MPa)
· Max. Operating Pressure	600 psi (4.14 MPa)
· Max. Feed Flow Rate	75 gpm (17.0 m ³ /hr)
· Min. Concentrate Flow Rate	16 gpm (3.6 m ³ /hr)
· Max. Operating Temperature	113 °F (45 °C)
· Operating pH Range	2.0–11.0
· CIP pH Range	1.0–13.0
· Max. Turbidity	1.0 NTU
· Max. SDI (15 min)	5.0
· Max. Chlorine Concentration	< 0.1 mg/L

Design Guidelines for Various Water Sources

· Wastewater Conventional (SDI < 5)	8–12 gfd
· Wastewater Pretreated by UF/MF (SDI < 3)	10–14 gfd
· Seawater, Open Intake (SDI < 5)	7–10 gfd
· Seawater, Beach Well (SDI < 3)	8–12 gfd
· Surface Water (SDI < 5)	12–16 gfd
· Surface Water (SDI < 3)	13–17 gfd
· Well water (SDI < 3)	13–17 gfd
· RO permeate (SDI < 1)	21–30 gfd

Saturation Limits (Using Antiscalants)[†]

· Langelier Saturation Index (LSI)	<+1.5
· Stiff and Davis Saturation Index (SDSI)	<+0.5
· CaSO ₄	230% saturation
· SrSO ₄	800% saturation
· BaSO ₄	6,000% saturation
· SiO ₂	100% saturation

[†]The above saturation limits are typically accepted by proprietary antiscalant manufacturers. It is the user's responsibility to ensure proper chemical(s) and concentration are dosed ahead of the membrane system to prevent scale formation anywhere within the membrane system. Membrane elements fouled or damaged due to scale formation are not covered by the limited warranty.

GENERAL HANDLING PROCEDURES

- Elements contained in the boxes must be kept dry at room temperature (7–32°C; 40–95°F) and should not be stored in direct sunlight. If the polyethylene bag is damaged, a new preservative solution (sodium bisulfite) must be added and air-tight sealed to prevent drying and biological growth.
- Permeate from the first hour of operation should be discarded to flush out the preservative solution.
- Elements should be immersed in a preservative solution during storage, shipping and system shutdowns to prevent biological growth and freezing. The standard storage solution contains 1% by weight sodium bisulfite or sodium metabisulfite (food grade). For short term storage (i.e. one week or less) 1% by weight sodium metabisulfite solution is adequate for preventing biological growth.
- Keep elements moist at all times after initial wetting.
- Avoid excessive pressure and flow spikes.
- Only use chemicals compatible with the membrane elements and components. Use of such chemicals may void the element limited warranty.
- Permeate pressure must always be equal or less than the feed/concentrate pressure. Damage caused by permeate back pressure voids the element limited warranty.



Ref. MCRE8040-FL

RE8040-FL

Fouling resistant RO element with low pressure for brackish water and wastewater reuse

CSM[®]

SPECIFICATIONS:

General Features	Permeate flow rate:	11,000 GPD (41.6 m ³ /day)
	Nominal salt rejection:	99.0%
	Effective membrane area:	400 ft ² (37.2 m ²)

- The stated product performance is based on data taken after 30 minutes of operation at the following test conditions:
 - 1,500 mg/L NaCl solution at 150 psig (1.0 MPa) applied pressure
 - 15% recovery
 - 77 °F (25 °C)
 - pH 6.5–7.0
- Minimum salt rejection is 98.5%.
- Permeate flow rate for each element may vary but will be no more than 10%.
- All elements are vacuum sealed in a polyethylene bag containing 1.0% SBS (sodium bisulfite) solution and individually packaged in a cardboard box.

Membrane type:	Thin-Film Composite
Membrane material:	Polyamide (PA)
Element configuration:	Spiral-Wound, FRP Wrapping

Dimensions **A** = 40.0 inch (1,016 mm) **B** = 8.0 inch (201 mm) **C** = 1.12 inch (28 mm)



- Each membrane element supplied with one brine seal, one interconnector (coupler) and four o-rings.
- All RE8040 elements fit nominal 8.0 inch (201 mm) I.D. pressure vessels.

The information provided in this document is solely for informative purposes. It is the user's responsibility to ensure the appropriate usage of this product. Woongjin Chemical assumes no obligation, liability or damages incurred for the misuse of the product or for the information provided in this document. This document does not express or imply any warranty as to the merchantability or fitness of the product.



RE8040-FL

CSM[®]

Fouling resistant RO element with low pressure for brackish water and wastewater reuse

APPLICATION DATA:

Operating Limits

· Max. Pressure Drop / Element	15 psi (0.1 MPa)
· Max. Pressure Drop / 240" Vessel	60 psi (0.41 MPa)
· Max. Operating Pressure	600 psi (4.14 MPa)
· Max. Feed Flow Rate	75 gpm (17.0 m ³ /hr)
· Min. Concentrate Flow Rate	16 gpm (3.6 m ³ /hr)
· Max. Operating Temperature	113 °F (45 °C)
· Operating pH Range	2.0–11.0
· CIP pH Range	1.0–13.0
· Max. Turbidity	1.0 NTU
· Max. SDI (15 min)	5.0
· Max. Chlorine Concentration	< 0.1 mg/L

Design Guidelines for Various Water Sources

· Wastewater Conventional (SDI < 5)	8–12 gfd
· Wastewater Pretreated by UF/MF (SDI < 3)	10–14 gfd
· Seawater; Open Intake (SDI < 5)	7–10 gfd
· Seawater; Beach Well (SDI < 3)	8–12 gfd
· Surface Water (SDI < 5)	12–16 gfd
· Surface Water (SDI < 3)	13–17 gfd
· Well water (SDI < 3)	13–17 gfd
· RO permeate (SDI < 1)	21–30 gfd

Saturation Limits (Using Antiscalants)[†]

· Langelier Saturation Index (LSI)	<+1.5
· Stiff and Davis Saturation Index (SDSI)	<+0.5
· CaSO ₄	230% saturation
· SrSO ₄	800% saturation
· BaSO ₄	6,000% saturation
· SiO ₂	100% saturation

[†]The above saturation limits are typically accepted by proprietary antiscalant manufacturers. It is the user's responsibility to ensure proper chemical(s) and concentration are dosed ahead of the membrane system to prevent scale formation anywhere within the membrane system. Membrane elements fouled or damaged due to scale formation are not covered by the limited warranty.

GENERAL HANDLING PROCEDURES

- Elements contained in the boxes must be kept dry at room temperature (7–32°C; 40–95°F) and should not be stored in direct sunlight. If the polyethylene bag is damaged, a new preservative solution (sodium bisulfite) must be added and air-tight sealed to prevent drying and biological growth.
- Permeate from the first hour of operation should be discarded to flush out the preservative solution.
- Elements should be immersed in a preservative solution during storage, shipping and system shutdowns to prevent biological growth and freezing. The standard storage solution contains 1% by weight sodium bisulfite or sodium metabisulfite (food grade). For short term storage (i.e. one week or less) 1% by weight sodium metabisulfite solution is adequate for preventing biological growth.
- Keep elements moist at all times after initial wetting.
- Avoid excessive pressure and flow spikes.
- Only use chemicals compatible with the membrane elements and components. Use of such chemicals may void the element limited warranty.
- Permeate pressure must always be equal or less than the feed/concentrate pressure. Damage caused by permeate back pressure voids the element limited warranty.



Ref. MCRE8040-FLR

RE8040-FLR

Fouling resistant RO element with low pressure for brackish water and wastewater reuse

CSM[®]

SPECIFICATIONS:

General Features	Permeate flow rate:	9,000 GPD (34.0 m ³ /day)
	Nominal salt rejection:	99.6%
	Effective membrane area:	400 ft ² (37.2 m ²)

- The stated product performance is based on data taken after 30 minutes of operation at the following test conditions:
 - 1,500 mg/L NaCl solution at 150 psig (1.0 MPa) applied pressure
 - 15% recovery
 - 77 °F (25 °C)
 - pH 6.5–7.0
- Minimum salt rejection is 99.5%.
- Permeate flow rate for each element may vary but will be no more than 10%.
- All elements are vacuum sealed in a polyethylene bag containing 1.0% SBS (sodium bisulfite) solution and individually packaged in a cardboard box.

Membrane type:	Thin-Film Composite
Membrane material:	Polyamide (PA)
Element configuration:	Spiral-Wound, FRP Wrapping

Dimensions **A = 40.0 inch (1,016 mm)** **B = 8.0 inch (201 mm)** **C = 1.12 inch (28 mm)**



- Each membrane element supplied with one brine seal, one interconnector (coupler) and four o-rings.
- All RE8040 elements fit nominal 8.0 inch (201 mm) I.D. pressure vessels.

The information provided in this document is solely for informative purposes. It is the user's responsibility to ensure the appropriate usage of this product. Woongjin Chemical assumes no obligation, liability or damages incurred for the misuse of the product or for the information provided in this document. This document does not express or imply any warranty as to the merchantability or fitness of the product.



RE8040-FLR

Fouling resistant RO element with low pressure for brackish water and wastewater reuse

CSM[®]

APPLICATION DATA:

Operating Limits

· Max. Pressure Drop / Element	15 psi (0.1 MPa)
· Max. Pressure Drop / 240" Vessel	60 psi (0.41 Mpa)
· Max. Operating Pressure	600 psi (4.14 MPa)
· Max. Feed Flow Rate	75 gpm (17.0 m ³ /hr)
· Min. Concentrate Flow Rate	16 gpm (3.6 m ³ /hr)
· Max. Operating Temperature	113 °F (45 °C)
· Operating pH Range	2.0–11.0
· CIP pH Range	1.0–13.0
· Max. Turbidity	1.0 NTU
· Max. SDI (15 min)	5.0
· Max. Chlorine Concentration	< 0.1 mg/L

Design Guidelines for Various Water Sources

· Wastewater Conventional (SDI < 5)	8–12 gfd
· Wastewater Pretreated by UF/MF (SDI < 3)	10–14 gfd
· Seawater, Open Intake (SDI < 5)	7–10 gfd
· Seawater, Beach Well (SDI < 3)	8–12 gfd
· Surface Water (SDI < 5)	12–16 gfd
· Surface Water (SDI < 3)	13–17 gfd
· Well water (SDI < 3)	13–17 gfd
· RO permeate (SDI < 1)	21–30 gfd

Saturation Limits (Using Antiscalants)[†]

· Langelier Saturation Index (LSI)	<+1.5
· Stiff and Davis Saturation Index (SDSI)	<+0.5
· CaSO ₄	230% saturation
· SrSO ₄	800% saturation
· BaSO ₄	6,000% saturation
· SiO ₂	100% saturation

[†]The above saturation limits are typically accepted by proprietary antiscalant manufacturers. It is the user's responsibility to ensure proper chemical(s) and concentration are dosed ahead of the membrane system to prevent scale formation anywhere within the membrane system. Membrane elements fouled or damaged due to scale formation are not covered by the limited warranty.

GENERAL HANDLING PROCEDURES

- Elements contained in the boxes must be kept dry at room temperature (7–32°C; 40–95°F) and should not be stored in direct sunlight. If the polyethylene bag is damaged, a new preservative solution (sodium bisulfite) must be added and air-tight sealed to prevent drying and biological growth.
- Permeate from the first hour of operation should be discarded to flush out the preservative solution.
- Elements should be immersed in a preservative solution during storage, shipping and system shutdowns to prevent biological growth and freezing. The standard storage solution contains 1% by weight sodium bisulfite or sodium metabisulfite (food grade). For short term storage (i.e. one week or less) 1% by weight sodium metabisulfite solution is adequate for preventing biological growth.
- Keep elements moist at all times after initial wetting.
- Avoid excessive pressure and flow spikes.
- Only use chemicals compatible with the membrane elements and components. Use of such chemicals may void the element limited warranty.
- Permeate pressure must always be equal or less than the feed/concentrate pressure. Damage caused by permeate back pressure voids the element limited warranty.

TORAY 8" Membranes



Ref. MTML20D-400



Low fouling and high tolerance RO

T M L (D)

Type	Diameter Inch	Membrane Area ft ² (m ²)	Salt Rejection %	Product Flow Rate gpd(m ³ /d)	Feed Spacer Thickness mil
TML20D-400	8"	400(37)	99.8	10,500(39.7)	34

1. Membrane Type		Cross Linked Fully Aromatic Polyamide Composite
2. Test Conditions	Feed Water Pressure Feed Water Temperature Feed Water Concentration Recovery Rate Feed Water pH	225 psi(1.55 MPa) 77 ° F(25 °C) 2,000 mg/l NaCl 15 % 7
3. Minimum Salt Rejection		99.65 %
4. Minimum Product Flow Rate		8,400 gpd(31.8 m ³ /d)

Dimensions

All dimensions shown in Inches (millimeter).

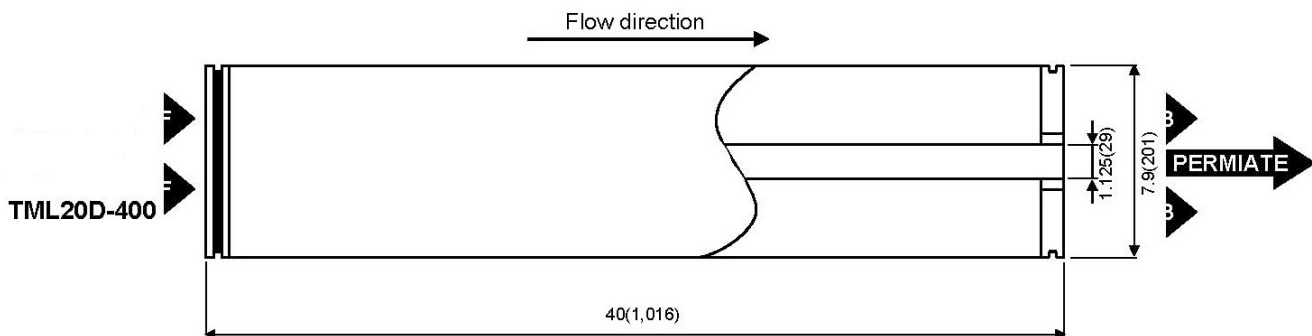
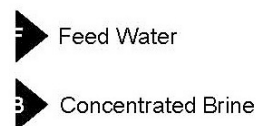



Operating Limits

Maximum Operating Pressure	600psi (4.1 MPa)
Maximum Feed Water Temperature	113° F (45°C)
Maximum Feed Water SDI ₁₅	5
Feed Water Chlorine Concentration	<0.1ppm
Feed Water pH Range, Continuous Operation	2-11
Feed Water pH Range, Chemical Cleaning	1-13
Maximum Pressure Drop per Element	15 psi (0.10 MPa)
Maximum Pressure Drop per Vessel	50 psi (0.34 MPa)

Operating Information

1. For the recommended design range, please consult the latest Toray technical bulletin, design guide lines, computer design program, and/ or call an application specialist. If the operating limits given in this Product Information Bulletin are not strictly followed, the Limited Warranty will be null and void.
2. All elements are wet tested, treated with a 1% by weight percent sodium bisulfite storage solution, and then vacuum packed in oxygen barrier bags, or treated with tested feed water solution, and then vacuum packed in oxygen barrier bags with deoxidant inside. To prevent biological growth during short term storage, shipment, or system shutdown, it is recommended that Toray elements be immersed in a protective solution containing 500 - 1,000 ppm of sodium bisulfite (food grade) dissolved in permeate.
3. The presence of free chlorine and other oxidizing agents under certain conditions, such as heavy metals which acts as oxidation catalyst in the feed water will cause unexpected oxidation of the membrane. It is strongly recommended to remove these oxidizing agents contained in feed water before operating RO system.
4. Permeate from the first hour of operation shall be discarded.
5. The customer is fully responsible for the effects of chemicals that are incompatible with the elements. Their use will void the element Limited Warranty.

Notice

1. Toray accepts no responsibility for results obtained by the application of this information or the safety or suitability of Toray's products, either alone or in combination with other products. Users are advised to make their own tests to determine the safety and suitability of each product combination for their own purposes.
2. All data may change without prior notice, due to technical modifications or production changes.

TORAY 8" Membranes



Ref. MTM820M-400

TORAY
Innovation by Chemistry

Standard SWRO TM800M

Type	Diameter Inch	Membrane Area ft ² (m ²)	Salt Rejection %	Product Flow Rate gpd(m ³ / d)	Feed Spacer Thickness mil
TM820M-400	8"	400(37)	99.8	7,000(26.5)	34

1. Membrane Type		Cross Linked Fully Aromatic Polyamide Composite
2. Test Conditions	Feed Water Pressure Feed Water Temperature Feed Water Concentration Recovery Rate Feed Water pH	800 psi(5.52MPa) 77° F(25°C) 32,000 mg/l NaCl 8% 7
3. Minimum Salt Rejection		99.5%
4. Minimum Product Flow Rate		5,600gpd(21.2m ³ /d)
5. Boron Rejection (typical value)		95% at pH 8 (5mg/l Boron added to Feed water)

Dimensions

All dimensions shown in Inches (millimeter).

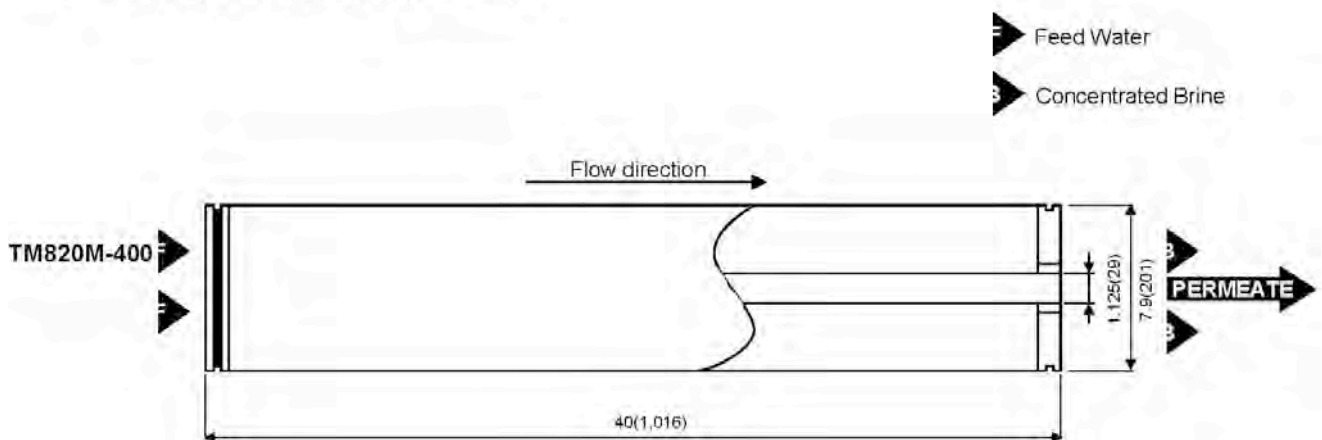



Operating Limits

Maximum Operating Pressure	1200psi (8.3 MPa)
Maximum Feed Water Temperature	113° F (45°C)
Maximum Feed Water SDI ₁₅	5
Feed Water Chlorine Concentration	Not detectable
Feed Water pH Range, Continuous Operation	2-11
Feed Water pH Range, Chemical Cleaning	1-12
Maximum Pressure Drop per Element	15 psi (0.10 MPa)
Maximum Pressure Drop per Vessel	50 psi (0.34 MPa)

Operating Information

1. For the recommended design range, please consult the latest Toray technical bulletin, design guidelines, computer design program, and/ or call an application specialist. If the operating limits given in this Product Information Bulletin are not strictly followed, the Limited Warranty will be null and void.
 2. All elements are wet tested, treated with tested feed water solution, and then vacuum packed in oxygen barrier bags with deoxidant inside. To prevent biological growth during system shutdown, it is recommended to perform 30-60 minutes flushing of Toray elements with seawater once in every two days.
 3. The presence of free chlorine and other oxidizing agents under certain conditions, such as heavy metals which acts as oxidation catalyst in the feed water will cause unexpected oxidation of the membrane. It is strongly recommended to remove these oxidizing agents contained in feed water before operating RO system.
 4. Permeate from the first hour of operation shall be discarded.
 5. The customer is fully responsible for the effects of chemicals that are incompatible with the elements. Their use will void the element Limited Warranty.
-

Notice

1. Toray accepts no responsibility for results obtained by the application of this information or the safety or suitability of Toray's products, either alone or in combination with other products. Users are advised to make their own tests to determine the safety and suitability of each product combination for their own purposes.
2. All data may change without prior notice, due to technical modifications or production changes.

TORAY 8" Membranes



Ref. MTM820M-440

TORAY
Innovation by Chemistry

Standard SWRO

TM800M

Type	Diameter Inch	Membrane Area ft ² (m ²)	Salt Rejection %	Product Flow Rate gpd(m ³ / d)	Feed Spacer Thickness mil
TM820M-440	8"	440(41)	99.8	7,700(29.2)	28

1. Membrane Type		Cross Linked Fully Aromatic Polyamide Composite
2. Test Conditions	Feed Water Pressure Feed Water Temperature Feed Water Concentration Recovery Rate Feed Water pH	800 psi(5.52MPa) 77° F(25°C) 32,000 mg/l NaCl 8% 7
3. Minimum Salt Rejection		99.5%
4. Minimum Product Flow Rate		6,200gpd(23.5m ³ /d)
5. Boron Rejection (typical value)		95% at pH 8 (5mg/l Boron added to Feed water)

Dimensions

All dimensions shown in Inches (millimeter).

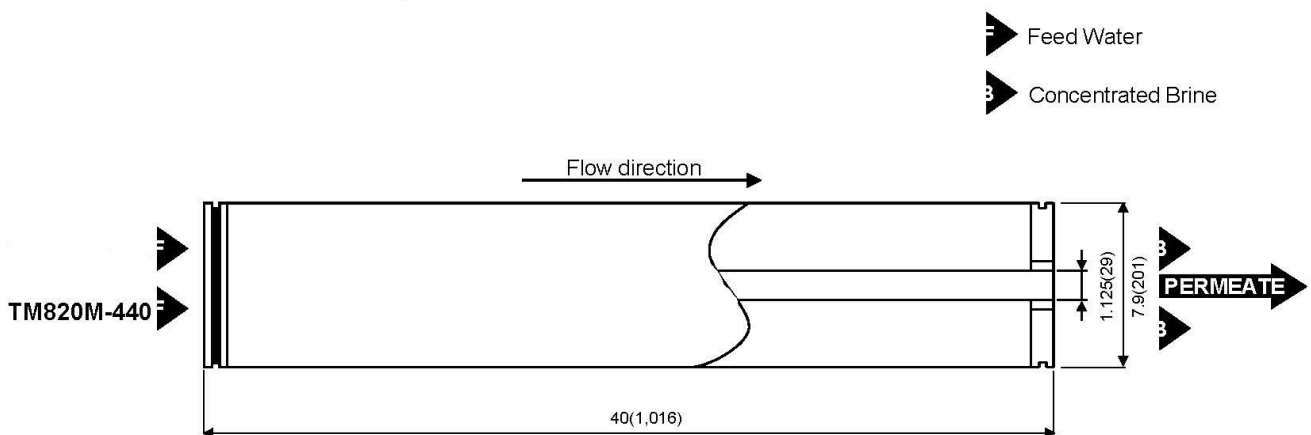



Operating Limits

Maximum Operating Pressure	1200psi (8.3 MPa)
Maximum Feed Water Temperature	113° F (45°C)
Maximum Feed Water SDI15	5
Feed Water Chlorine Concentration	Not detectable
Feed Water pH Range, Continuous Operation	2-11
Feed Water pH Range, Chemical Cleaning	1-12
Maximum Pressure Drop per Element	15 psi (0.10 MPa)
Maximum Pressure Drop per Vessel	50 psi (0.34 MPa)

Operating Information

1. For the recommended design range, please consult the latest Toray technical bulletin, design guidelines, computer design program, and/ or call an application specialist. If the operating limits given in this Product Information Bulletin are not strictly followed, the Limited Warranty will be null and void.
2. All elements are wet tested, treated with tested feed water solution, and then vacuum packed in oxygen barrier bags with deoxidant inside. To prevent biological growth during system shutdown, it is recommended to perform 30-60 minutes flushing of Toray elements with seawater once in every two days.
3. The presence of free chlorine and other oxidizing agents under certain conditions, such as heavy metals which acts as oxidation catalyst in the feed water will cause unexpected oxidation of the membrane. It is strongly recommended to remove these oxidizing agents contained in feed water before operating RO system.
4. Permeate from the first hour of operation shall be discarded.
5. The customer is fully responsible for the effects of chemicals that are incompatible with the elements. Their use will void the element Limited Warranty.

Notice

1. Toray accepts no responsibility for results obtained by the application of this information or the safety or suitability of Toray's products, either alone or in combination with other products. Users are advised to make their own tests to determine the safety and suitability of each product combination for their own purposes.
2. All data may change without prior notice, due to technical modifications or production changes.

TORAY 8" Membranes



Ref. MTM820V-400

TORAY
Innovation by Chemistry

Low energy SWRO

TM800V

Type	Diameter Inch	Membrane Area ft ² (m ²)	Salt Rejection %	Product Flow Rate gpd(m ³ / d)	Feed Spacer Thickness mil
TM820V-400	8"	400(37)	99.8	9,000(34.1)	34

1. Membrane Type		Cross Linked Fully Aromatic Polyamide Composite
2. Test Conditions	Feed Water Pressure Feed Water Temperature Feed Water Concentration Recovery Rate Feed Water pH	800 psi(5.52MPa) 77° F(25°C) 32,000 mg/l NaCl 8% 7
3. Minimum Salt Rejection		99.5%
4. Minimum Product Flow Rate		7,500gpd(28.4m ³ /d)
5. Boron Rejection (typical value)		92% at pH 8 (5mg/l Boron added to Feed water)

Dimensions

All dimensions shown in Inches (millimeter).

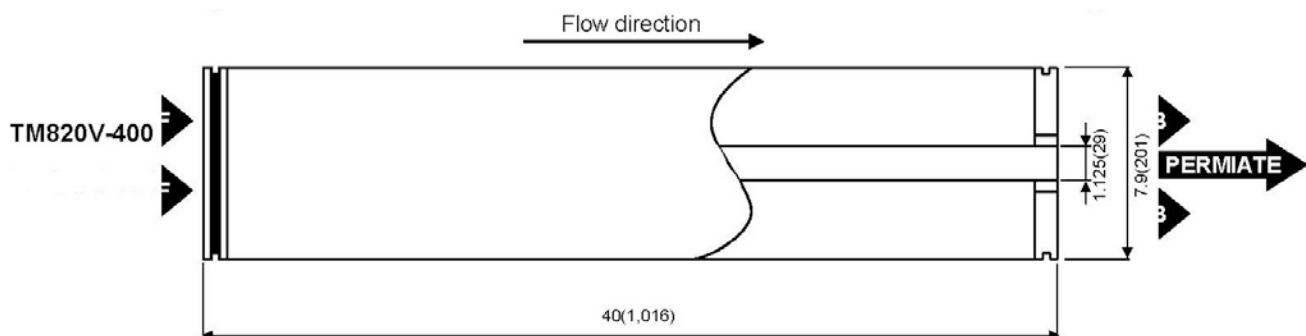



Operating Limits

Maximum Operating Pressure	1200psi (8.3 MPa)
Maximum Feed Water Temperature	113° F (45°C)
Maximum Feed Water SDI ₁₅	5
Feed Water Chlorine Concentration	Not detectable
Feed Water pH Range, Continuous Operation	2-11
Feed Water pH Range, Chemical Cleaning	1-12
Maximum Pressure Drop per Element	15 psi (0.10 MPa)
Maximum Pressure Drop per Vessel	50 psi (0.34 MPa)

Operating Information

1. For the recommended design range, please consult the latest Toray technical bulletin, design guidelines, computer design program, and/ or call an application specialist. If the operating limits given in this Product Information Bulletin are not strictly followed, the Limited Warranty will be null and void.
 2. All elements are wet tested, treated with tested feed water solution, and then vacuum packed in oxygen barrier bags with deoxidant inside. To prevent biological growth during system shutdown, it is recommended to perform 30-60 minutes flushing of Toray elements with seawater once in every two days.
 3. The presence of free chlorine and other oxidizing agents under certain conditions, such as heavy metals which acts as oxidation catalyst in the feed water will cause unexpected oxidation of the membrane. It is strongly recommended to remove these oxidizing agents contained in feed water before operating RO system.
 4. Permeate from the first hour of operation shall be discarded.
 5. The customer is fully responsible for the effects of chemicals that are incompatible with the elements. Their use will void the element Limited Warranty.
-

Notice

1. Toray accepts no responsibility for results obtained by the application of this information or the safety or suitability of Toray's products, either alone or in combination with other products. Users are advised to make their own tests to determine the safety and suitability of each product combination for their own purposes.
2. All data may change without prior notice, due to technical modifications or production changes.



Ref. MCNE8040-90

NE8040-90

Normal grade NF element with high monovalent ion rejection

CSM®

SPECIFICATIONS:

General Features	Permeate flow rate ¹ :	7,500 GPD (28.4 m ³ /day)
	Monovalent ion rejection (NaCl) ¹ :	85.0 – 95.0%
	Divalent ion rejection (CaCl ₂) ² :	90.0 – 95.0%
	Effective membrane area:	400 ft ² (37.2 m ²)

1. The stated product performance is based on data taken after 30 minutes of operation at the following monovalent test conditions:

- 2,000 mg/L NaCl solution at 75 psig (0.5 MPa) applied pressure
- 15% recovery
- 77 °F (25 °C)
- pH 6.5–7.0

2. The stated product performance is based on data taken after 30 minutes of operation at the following divalent test conditions:

- 500 mg/L CaCl₂ solution at 75 psig (0.5 MPa) applied pressure
- 15% recovery
- 77 °F (25 °C)
- pH 6.5–7.0

3. MgSO₄ rejection is 97.0%. (Test conditions are equivalent with NaCl)

4. Permeate flow rate for each element may vary but will be no more than 15%.

5. All elements are vacuum sealed in a polyethylene bag containing 1.0% SBS (sodium bisulfite) solution and individually packaged in a cardboard box.

Membrane type:	Thin-Film Composite
Membrane material:	Polyamide (PA)
Element configuration:	Spiral-Wound, FRP Wrapping

Dimensions A = 40.0 inch (1,016 mm) B = 8.0 inch (203 mm) C = 1.12 inch (28 mm)



1. Each membrane element supplied with one brine seal, one interconnector (coupler) and four o-rings.
2. All NE8040 elements fit nominal 8.0 inch (203 mm) I.D. pressure vessels.

The information provided in this document is solely for informative purposes. It is the user's responsibility to ensure the appropriate usage of this product. Woongjin Chemical assumes no obligation, liability or damages incurred for the misuse of the product or for the information provided in this document. This document does not express or imply any warranty as to the merchantability or fitness of the product.



NE8040-90

Normal grade NF element with high monovalent ion rejection

CSM[®]

APPLICATION DATA:

Operating Limits

· Max. Pressure Drop / Element	15 psi (0.1 MPa)
· Max. Pressure Drop / 240" Vessel	60 psi (0.41 Mpa)
· Max. Operating Pressure	600 psi (4.14 MPa)
· Max. Feed Flow Rate	75 gpm (17.0 m ³ /hr)
· Min. Concentrate Flow Rate	16 gpm (3.6 m ³ /hr)
· Max. Operating Temperature	113 °F (45 °C)
· Operating pH Range	2.0–11.0
· CIP pH Range	1.0–13.0
· Max. Turbidity	1.0 NTU
· Max. SDI (15 min)	5.0
· Max. Chlorine Concentration	< 0.1 mg/L

Design Guidelines for Various Water Sources

· Wastewater Conventional (SDI < 5)	8–12 gfd
· Wastewater Pretreated by UF/MF (SDI < 3)	10–14 gfd
· Seawater, Open Intake (SDI < 5)	7–10 gfd
· Seawater, Beach Well (SDI < 3)	8–12 gfd
· Surface Water (SDI < 5)	12–16 gfd
· Surface Water (SDI < 3)	13–17 gfd
· Well water (SDI < 3)	13–17 gfd
· RO permeate (SDI < 1)	21–30 gfd

Saturation Limits (Using Antiscalants)[†]

· Langelier Saturation Index (LSI)	<+1.5
· Stiff and Davis Saturation Index (SDSI)	<+0.5
· CaSO ₄	230% saturation
· SrSO ₄	800% saturation
· BaSO ₄	6,000% saturation
· SiO ₂	100% saturation

[†]The above saturation limits are typically accepted by proprietary antiscalant manufacturers. It is the user's responsibility to ensure proper chemical(s) and concentration are dosed ahead of the membrane system to prevent scale formation anywhere within the membrane system. Membrane elements fouled or damaged due to scale formation are not covered by the limited warranty.

GENERAL HANDLING PROCEDURES

- Elements contained in the boxes must be kept dry at room temperature (7–32°C; 40–95°F) and should not be stored in direct sunlight. If the polyethylene bag is damaged, a new preservative solution (sodium bisulfite) must be added and air-tight sealed to prevent drying and biological growth.
- Permeate from the first hour of operation should be discarded to flush out the preservative solution.
- Elements should be immersed in a preservative solution during storage, shipping and system shutdowns to prevent biological growth and freezing. The standard storage solution contains 1% by weight sodium bisulfite or sodium metabisulfite (food grade). For short term storage (i.e. one week or less) 1% by weight sodium metabisulfite solution is adequate for preventing biological growth.
- Keep elements moist at all times after initial wetting.
- Avoid excessive pressure and flow spikes.
- Only use chemicals compatible with the membrane elements and components. Use of such chemicals may void the element limited warranty.
- Permeate pressure must always be equal or less than the feed/concentrate pressure. Damage caused by permeate back pressure voids the element limited warranty.



Ref. MCNE8040-70

NE8040-70

Normal grade NF element with medium monovalent ion rejection

CSM[®]

SPECIFICATIONS:

General Features	Permeate flow rate ¹ :	7,000 GPD (26.5 m ³ /day)
	Monovalent ion rejection (NaCl) ¹ :	40.0 – 70.0%
	Divalent ion rejection (CaCl ₂) ² :	45.0 – 70.0%
	Effective membrane area:	400 ft ² (37.2 m ²)

- The stated product performance is based on data taken after 30 minutes of operation at the following monovalent test conditions:
 - 2,000 mg/L NaCl solution at 75 psig (0.5 MPa) applied pressure
 - 15% recovery
 - 77 °F (25 °C)
 - pH 6.5–7.0
- The stated product performance is based on data taken after 30 minutes of operation at the following divalent test conditions:
 - 500 mg/L CaCl₂ solution at 75 psig (0.5 MPa) applied pressure
 - 15% recovery
 - 77 °F (25 °C)
 - pH 6.5–7.0
- MgSO₄ rejection is 97.0%. (Test conditions are equivalent with NaCl)
- Permeate flow rate for each element may vary but will be no more than 15%.
- All elements are vacuum sealed in a polyethylene bag containing 1.0% SBS (sodium bisulfite) solution and individually packaged in a cardboard box.

Membrane type:	Thin-Film Composite
Membrane material:	Polyamide (PA)
Element configuration:	Spiral-Wound, FRP Wrapping

Dimensions A = 40.0 inch (1,016 mm) B = 8.0 inch (203 mm) C = 1.12 inch (28 mm)



- Each membrane element supplied with one brine seal, one interconnector (coupler) and four o-rings.
- All NE8040 elements fit nominal 8.0 inch (203 mm) I.D. pressure vessels.

The information provided in this document is solely for informative purposes. It is the user's responsibility to ensure the appropriate usage of this product. Woongjin Chemical assumes no obligation, liability or damages incurred for the misuse of the product or for the information provided in this document. This document does not express or imply any warranty as to the merchantability or fitness of the product.



NE8040-70

Normal grade NF element with medium monovalent ion rejection

CSM®

APPLICATION DATA:

Operating Limits

· Max. Pressure Drop / Element	15 psi (0.1 MPa)
· Max. Pressure Drop / 240" Vessel	60 psi (0.41 MPa)
· Max. Operating Pressure	600 psi (4.14 MPa)
· Max. Feed Flow Rate	75 gpm (16.0 m ³ /hr)
· Min. Concentrate Flow Rate	16 gpm (3.6 m ³ /hr)
· Max. Operating Temperature	113 °F (45 °C)
· Operating pH Range	2.0–11.0
· CIP pH Range	1.0–13.0
· Max. Turbidity	1.0 NTU
· Max. SDI (15 min)	5.0
· Max. Chlorine Concentration	< 0.1 mg/L

Design Guidelines for Various Water Sources

· Wastewater Conventional (SDI < 5)	8–12 gfd
· Wastewater Pretreated by UF/MF (SDI < 3)	10–14 gfd
· Seawater, Open Intake (SDI < 5)	7–10 gfd
· Seawater, Beach Well (SDI < 3)	8–12 gfd
· Surface Water (SDI < 5)	12–16 gfd
· Surface Water (SDI < 3)	13–17 gfd
· Well water (SDI < 3)	13–17 gfd
· RO permeate (SDI < 1)	21–30 gfd

Saturation Limits (Using Antiscalants)[†]

· Langelier Saturation Index (LSI)	<+1.5
· Stiff and Davis Saturation Index (SDSI)	<+0.5
· CaSO ₄	230% saturation
· SrSO ₄	800% saturation
· BaSO ₄	6,000% saturation
· SiO ₂	100% saturation

[†]The above saturation limits are typically accepted by proprietary antiscalant manufacturers. It is the user's responsibility to ensure proper chemical(s) and concentration are dosed ahead of the membrane system to prevent scale formation anywhere within the membrane system. Membrane elements fouled or damaged due to scale formation are not covered by the limited warranty.

GENERAL HANDLING PROCEDURES

- Elements contained in the boxes must be kept dry at room temperature (7–32°C; 40–95°F) and should not be stored in direct sunlight. If the polyethylene bag is damaged, a new preservative solution (sodium bisulfite) must be added and air-tight sealed to prevent drying and biological growth.
- Permeate from the first hour of operation should be discarded to flush out the preservative solution.
- Elements should be immersed in a preservative solution during storage, shipping and system shutdowns to prevent biological growth and freezing. The standard storage solution contains 1% by weight sodium bisulfite or sodium metabisulfite (food grade). For short term storage (i.e. one week or less) 1% by weight sodium metabisulfite solution is adequate for preventing biological growth.
- Keep elements moist at all times after initial wetting.
- Avoid excessive pressure and flow spikes.
- Only use chemicals compatible with the membrane elements and components. Use of such chemicals may void the element limited warranty.
- Permeate pressure must always be equal or less than the feed/concentrate pressure. Damage caused by permeate back pressure voids the element limited warranty.

CSM 8" Membranes



Ref. MCNE8040-40

NE8040-40

High productivity NF element

CSM[®]

SPECIFICATIONS:

General Features	Permeate flow rate¹:	13,500 GPD (51 m ³ /day)
	Monovalent ion rejection (NaCl):	20 – 60%
	Effective membrane area:	400 ft ² (37.2 m ²)

1. The stated product performance is based on data taken after 30 minutes of operation at the following monovalent test conditions:

- 2,000 mg/L NaCl solution at 75 psig (0.5 MPa) applied pressure
- 15% recovery
- 77 °F (25 °C)
- pH 6.5–7.0

2. MgSO₄ rejection is 97.0%. (Test conditions are equivalent with NaCl)

3. Permeate flow rate for each element may vary but will be no more than 20%.

4. All elements are vacuum sealed in a polyethylene bag containing 1.0% SBS (sodium bisulfite) solution and individually packaged in a cardboard box.

Membrane type:	Thin-Film Composite
Membrane material:	Polyamide (PA)
Element configuration:	Spiral-Wound, FRP Wrapping

Dimensions and Weight

Model Name	A	B	C	Weight	Part Number	
					Inter-connector	Brine Seal
NE8040-40	40.0 inch (1,016 mm)	8.0 inch (201 mm)	1.12 inch (28 mm)	15 kg	40000308	40000309

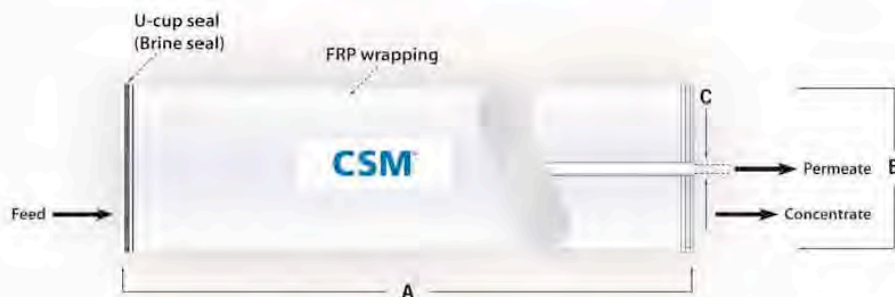

1. Each membrane element supplied with one brine seal, one interconnector (coupler) and four o-rings.
2. All NE8040 elements fit nominal 8.0 inch (201 mm) I.D. pressure vessels.

The information provided in this document is solely for informative purposes. It is the user's responsibility to ensure the appropriate usage of this product. Woongjin Chemical assumes no obligation, liability or damages incurred for the misuse of the product or for the information provided in this document. This document does not express or imply any warranty as to the merchantability or fitness of the product.



NE8040-40

High productivity NF element

APPLICATION DATA:

Operating Limits

· Max. Pressure Drop / Element	15 psi (0.1 MPa)
· Max. Pressure Drop / 240" Vessel	60 psi (0.41 MPa)
· Max. Operating Pressure	600 psi (4.14 MPa)
· Max. Feed Flow Rate	75 gpm (17.0 m ³ /hr)
· Min. Concentrate Flow Rate	16 gpm (3.6 m ³ /hr)
· Max. Operating Temperature	113 °F (45 °C)
· Operating pH Range	2.0–11.0
· CIP pH Range	1.0–13.0
· Max. Turbidity	1.0 NTU
· Max. SDI (15 min)	5.0
· Max. Chlorine Concentration	< 0.1 mg/L

Design Guidelines for Various Water Sources

· Wastewater Conventional (SDI < 5)	8–12 gfd
· Wastewater Pretreated by UF/MF (SDI < 3)	10–14 gfd
· Seawater, Open Intake (SDI < 5)	7–10 gfd
· Seawater, Beach Well (SDI < 3)	8–12 gfd
· Surface Water (SDI < 5)	12–16 gfd
· Surface Water (SDI < 3)	13–17 gfd
· Well water (SDI < 3)	13–17 gfd
· RO permeate (SDI < 1)	21–30 gfd

Saturation Limits (Using Antiscalants)[†]

· Langlier Saturation Index (LSI)	<+1.5
· Stiff and Davis Saturation Index (SDSI)	<+0.5
· CaSO ₄	230% saturation
· SrSO ₄	800% saturation
· BaSO ₄	6,000% saturation
· SiO ₂	100% saturation

[†]The above saturation limits are typically accepted by proprietary antiscalant manufacturers. It is the user's responsibility to ensure proper chemical(s) and concentration are dosed ahead of the membrane system to prevent scale formation anywhere within the membrane system. Membrane elements fouled or damaged due to scale formation are not covered by the limited warranty.

GENERAL HANDLING PROCEDURES

- Elements contained in the boxes must be kept dry at room temperature (7–32°C; 40–95°F) and should not be stored in direct sunlight. If the polyethylene bag is damaged, a new preservative solution (sodium bisulfite) must be added and air-tight sealed to prevent drying and biological growth.
- Permeate from the first hour of operation should be discarded to flush out the preservative solution.
- Elements should be immersed in a preservative solution during storage, shipping and system shutdowns to prevent biological growth and freezing. The standard storage solution contains 1% by weight sodium bisulfite or sodium metabisulfite (food grade). For short term storage (i.e. one week or less) 1% by weight sodium metabisulfite solution is adequate for preventing biological growth.
- Keep elements moist at all times after initial wetting.
- Avoid excessive pressure and flow spikes.
- Only use chemicals compatible with the membrane elements and components. Use of such chemicals may void the element limited warranty.
- Permeate pressure must always be equal or less than the feed/concentrate pressure. Damage caused by permeate back pressure voids the element limited warranty.

CSM 8" Membranes



Ref. MCRE8040-UE

RE8040-UE

Normal grade RO element for ultra pure water

CSM

SPECIFICATIONS:

General Features	Permeate flow rate:	9,000 GPD (34.1 m ³ /day)
	Nominal salt rejection:	99.5%
	Effective membrane area:	400 ft ² (37.2 m ²)

- The stated product performance is based on data taken after 30 minutes of operation at the following test conditions:
 - **2,000 mg/L NaCl solution at 225 psig (1.5 MPa) applied pressure**
 - **15% recovery**
 - **77 °F (25 °C)**
 - **pH 6.5–7.0**
- IPA rejection is 95.0% after 2 hours of operation at the following test conditions:
 - **1,000 mg/L IPA solution at 225 psig (1.5 MPa) applied pressure**
 - **15% recovery**
 - **77 °F (25 °C)**
 - **pH 6.5–7.0**
- Minimum salt rejection is 99.0%.
- Permeate flow rate for each element may vary but will be no more than 10% below the value shown.
- All elements are vacuum sealed in a polyethylene bag containing 1.0% SBS (sodium bisulfite) solution and individually packaged in a cardboard box.

Membrane type:	Thin-Film Composite
Membrane material:	Polyamide (PA)
Element configuration:	Spiral-Wound, FRP Wrapping

Dimensions A = 40.0 inch (1,016 mm) B = 8.0 inch (203 mm) C = 1.12 inch (28 mm)



- Each membrane element comes with one brine seal, one interconnector (coupler) and two o-rings.
- All RE8040 elements fit nominal 8.0 inch (203 mm) I.D. pressure vessels.

The information provided in this document is solely for informative purposes. It is the user's responsibility to ensure the appropriate usage of this product. Woongjin Chemical assumes no obligation, liability or damages incurred for the misuse of the product or for the information provided in this document. This document does not express or imply any warranty as to the merchantability or fitness of the product.



RE8040-UE

Normal grade RO element for ultra pure water

CSM®

APPLICATION DATA:

Operating Limits

• Max. Pressure Drop / Element	15 psi (0.1 MPa)
• Max. Pressure Drop / 240" Vessel	60 psi (0.41 MPa)
• Max. Operating Pressure	600 psi (4.14 MPa)
• Max. Feed Flow Rate	66 gpm (15.0 m ³ /hr)
• Min. Concentrate Flow Rate	16 gpm (3.6 m ³ /hr)
• Max. Operating Temperature	113 °F (45 °C)
• Operating pH Range	3.0–10.0
• CIP pH Range	2.0–11.0
• Max. Turbidity	1.0 NTU
• Max. SDI (15 min)	5.0
• Max. Chlorine Concentration	< 0.1 mg/L

Design Guidelines for Various Water Sources

• Wastewater Conventional (SDI < 5)	8–12 gfd
• Wastewater Pretreated by UF/MF (SDI < 3)	10–14 gfd
• Seawater, Open Intake (SDI < 5)	7–10 gfd
• Seawater, Beach Well (SDI < 3)	8–12 gfd
• Surface Water (SDI < 5)	12–16 gfd
• Surface Water (SDI < 3)	13–17 gfd
• Well water (SDI < 3)	13–17 gfd
• RO permeate (SDI < 1)	21–30 gfd

Saturation Limits (Using Antiscalants)[†]

• Langelier Saturation Index (LSI)	<+1.5
• Stiff and Davis Saturation Index (SDSI)	<+0.5
• CaSO ₄	230% saturation
• SrSO ₄	800% saturation
• BaSO ₄	6,000% saturation
• SiO ₂	100% saturation

[†]The above saturation limits are typically accepted by proprietary antiscalant manufacturers. It is the user's responsibility to ensure proper chemical(s) and concentration are dosed ahead of the membrane system to prevent scale formation anywhere within the membrane system. Membrane elements fouled or damaged due to scale formation are not covered by the limited warranty.

GENERAL HANDLING PROCEDURES

- Elements contained in the boxes must be kept dry at room temperature (7–32°C; 40–95°F) and should not be stored in direct sunlight. If the polyethylene bag is damaged, a new preservative solution (sodium bisulfite) must be added and air-tight sealed to prevent drying and biological growth.
- Permeate from the first hour of operation should be discarded to flush out the preservative solution.
- Elements should be immersed in a preservative solution during storage, shipping and system shutdowns to prevent biological growth and freezing. The standard storage solution contains 1% by weight sodium bisulfite or sodium metabisulfite (food grade). For short term storage (i.e. one week or less) 1% by weight sodium metabisulfite solution is adequate for preventing biological growth.
- Keep elements moist at all times after initial wetting.
- Avoid excessive pressure and flow spikes.
- Only use chemicals compatible with the membrane elements and components. Use of such chemicals may void the element limited warranty.
- Permeate pressure must always be equal or less than the feed/concentrate pressure. Damage caused by permeate back pressure voids the element limited warranty.



Ref. MCRE8040-HUE

RE8040-HUE

Normal grade RO element with high TOC rejection for ultra pure water

CSM[®]

SPECIFICATIONS:

General Features	Permeate flow rate:	9,000 GPD (34.1 m ³ /day)
	Nominal salt rejection:	99.5%
	Effective membrane area:	400 ft ² (37.2 m ²)

1. The stated product performance is based on data taken after 30 minutes of operation at the following test conditions:

- 2,000 mg/L NaCl solution at 225 psig (1.5 MPa) applied pressure
- 15% recovery
- 77 °F (25 °C)
- pH 6.5–7.0

2. IPA rejection is 96.0% after 2 hours of operation at the following test conditions:

- 1,000 mg/L IPA solution at 225 psig (1.5 MPa) applied pressure
- 15% recovery
- 77 °F (25 °C)
- pH 6.5–7.0

3. Minimum salt rejection is 99.4%.

4. Permeate flow rate for each element may vary but will be no more than 10% below the value shown.

5. All elements are vacuum sealed in a polyethylene bag containing 1.0% SBS (sodium bisulfite) solution and individually packaged in a cardboard box.

Membrane type:	Thin-Film Composite
Membrane material:	Polyamide (PA)
Element configuration:	Spiral-Wound, FRP Wrapping

Dimensions A = 40.0 inch (1,016 mm) B = 8.0 inch (203 mm) C = 1.12 inch (28 mm)



1. Each membrane element comes with one brine seal, one interconnector (coupler) and two o-rings.
2. All RE8040 elements fit nominal 8.0 inch (203 mm) I.D. pressure vessels.

The information provided in this document is solely for informative purposes. It is the user's responsibility to ensure the appropriate usage of this product. Woongjin Chemical assumes no obligation, liability or damages incurred for the misuse of the product or for the information provided in this document. This document does not express or implies any warranty as to the merchantability or fitness of the product.



RE8040-HUE

CSM[®]

Normal grade RO element with high TOC rejection for ultra pure water

APPLICATION DATA:

Operating Limits

· Max. Pressure Drop / Element	15 psi (0.1 MPa)
· Max. Pressure Drop / 240" Vessel	60 psi (0.41 MPa)
· Max. Operating Pressure	600 psi (4.14 MPa)
· Max. Feed Flow Rate	66 gpm (15.0 m ³ /hr)
· Min. Concentrate Flow Rate	16 gpm (3.6 m ³ /hr)
· Max. Operating Temperature	113 °F (45 °C)
· Operating pH Range	3.0–10.0
· CIP pH Range	2.0–11.0
· Max. Turbidity	1.0 NTU
· Max. SDI (15 min)	5.0
· Max. Chlorine Concentration	< 0.1 mg/L

Design Guidelines for Various Water Sources

· Wastewater Conventional (SDI < 5)	8–12 gfd
· Wastewater Pretreated by UF/MF (SDI < 3)	10–14 gfd
· Seawater, Open Intake (SDI < 5)	7–10 gfd
· Seawater, Beach Well (SDI < 3)	8–12 gfd
· Surface Water (SDI < 5)	12–16 gfd
· Surface Water (SDI < 3)	13–17 gfd
· Well water (SDI < 3)	13–17 gfd
· RO permeate (SDI < 1)	21–30 gfd

Saturation Limits (Using Antiscalants)[†]

· Langelier Saturation Index (LSI)	<+1.5
· Stiff and Davis Saturation Index (SDSI)	<+0.5
· CaSO ₄	230% saturation
· SrSO ₄	800% saturation
· BaSO ₄	6,000% saturation
· SiO ₂	100% saturation

[†]The above saturation limits are typically accepted by proprietary antiscalant manufacturers. It is the user's responsibility to ensure proper chemical(s) and concentration are dosed ahead of the membrane system to prevent scale formation anywhere within the membrane system. Membrane elements fouled or damaged due to scale formation are not covered by the limited warranty.

GENERAL HANDLING PROCEDURES

- Elements contained in the boxes must be kept dry at room temperature (7–32°C; 40–95°F) and should not be stored in direct sunlight. If the polyethylene bag is damaged, a new preservative solution (sodium bisulfite) must be added and air-tight sealed to prevent drying and biological growth.
- Permeate from the first hour of operation should be discarded to flush out the preservative solution.
- Elements should be immersed in a preservative solution during storage, shipping and system shutdowns to prevent biological growth and freezing. The standard storage solution contains 1% by weight sodium bisulfite or sodium metabisulfite (food grade). For short term storage (i.e. one week or less) 1% by weight sodium metabisulfite solution is adequate for preventing biological growth.
- Keep elements moist at all times after initial wetting.
- Avoid excessive pressure and flow spikes.
- Only use chemicals compatible with the membrane elements and components. Use of such chemicals may void the element limited warranty.
- Permeate pressure must always be equal or less than the feed/concentrate pressure. Damage caused by permeate back pressure voids the element limited warranty.



Ref. MCRE8040-HUE440

RE8040-HUE440

High TOC rejection RO element with extended area for ultra pure water

CSM[®]

SPECIFICATIONS:

General Features	Permeate flow rate:	10,000 GPD (37.9 m ³ /day)
	Nominal salt rejection:	99.5%
	Effective membrane area:	440 ft ² (40.9 m ²)

- The stated product performance is based on data taken after 30 minutes of operation at the following test conditions:
 - 2,000 mg/L NaCl solution at 225 psig (1.5 MPa) applied pressure
 - 15% recovery
 - 77 °F (25 °C)
 - pH 6.5–7.0
- IPA rejection is 96.0% after 2 hours of operation at the following test conditions:
 - 1,000 mg/L IPA solution at 225 psig (1.5 MPa) applied pressure
 - 15% recovery
 - 77 °F (25 °C)
 - pH 6.5–7.0
- Minimum salt rejection is 99.4%.
- Permeate flow rate for each element may vary but will be no more than 10% below the value shown.
- All elements are vacuum sealed in a polyethylene bag containing 1.0% SBS (sodium bisulfite) solution and individually packaged in a cardboard box.

Membrane type:	Thin-Film Composite
Membrane material:	Polyamide (PA)
Element configuration:	Spiral-Wound, FRP Wrapping

Dimensions **A** = 40.0 inch (1,016 mm) **B** = 8.0 inch (203 mm) **C** = 1.12 inch (28 mm)



- Each membrane element comes with one brine seal, one interconnector (coupler) and two o-rings.
- All RE8040 elements fit nominal 8.0 inch (203 mm) I.D. pressure vessels.

The information provided in this document is solely for informative purposes. It is the user's responsibility to ensure the appropriate usage of this product. Woongjin Chemical assumes no obligation, liability or damages incurred for the misuse of the product or for the information provided in this document. This document does not express or imply any warranty as to the merchantability or fitness of the product.



RE8040-HUE440

High TOC rejection RO element with extended area for ultra pure water

CSM[®]

APPLICATION DATA:

Operating Limits

• Max. Pressure Drop / Element	15 psi (0.1 MPa)
• Max. Pressure Drop / 240" Vessel	60 psi (0.41 MPa)
• Max. Operating Pressure	600 psi (4.14 MPa)
• Max. Feed Flow Rate	66 gpm (15.0 m ³ /hr)
• Min. Concentrate Flow Rate	16 gpm (3.6 m ³ /hr)
• Max. Operating Temperature	113 °F (45 °C)
• Operating pH Range	3.0–10.0
• CIP pH Range	2.0–11.0
• Max. Turbidity	1.0 NTU
• Max. SDI (15 min)	5.0
• Max. Chlorine Concentration	< 0.1 mg/L

Design Guidelines for Various Water Sources

• Wastewater Conventional (SDI < 5)	8–12 gfd
• Wastewater Pretreated by UF/MF (SDI < 3)	10–14 gfd
• Seawater, Open Intake (SDI < 5)	7–10 gfd
• Seawater, Beach Well (SDI < 3)	8–12 gfd
• Surface Water (SDI < 5)	12–16 gfd
• Surface Water (SDI < 3)	13–17 gfd
• Well water (SDI < 3)	13–17 gfd
• RO permeate (SDI < 1)	21–30 gfd

Saturation Limits (Using Antiscalants)[†]

• Langelier Saturation Index (LSI)	<+1.5
• Stiff and Davis Saturation Index (SDSI)	<+0.5
• CaSO ₄	230% saturation
• SrSO ₄	800% saturation
• BaSO ₄	6,000% saturation
• SiO ₂	100% saturation

[†]The above saturation limits are typically accepted by proprietary antiscalant manufacturers. It is the user's responsibility to ensure proper chemical(s) and concentration are dosed ahead of the membrane system to prevent scale formation anywhere within the membrane system. Membrane elements fouled or damaged due to scale formation are not covered by the limited warranty.

GENERAL HANDLING PROCEDURES

- Elements contained in the boxes must be kept dry at room temperature (7–32°C; 40–95°F) and should not be stored in direct sunlight. If the polyethylene bag is damaged, a new preservative solution (sodium bisulfite) must be added and air-tight sealed to prevent drying and biological growth.
- Permeate from the first hour of operation should be discarded to flush out the preservative solution.
- Elements should be immersed in a preservative solution during storage, shipping and system shutdowns to prevent biological growth and freezing. The standard storage solution contains 1% by weight sodium bisulfite or sodium metabisulfite (food grade). For short term storage (i.e. one week or less) 1% by weight sodium metabisulfite solution is adequate for preventing biological growth.
- Keep elements moist at all times after initial wetting.
- Avoid excessive pressure and flow spikes.
- Only use chemicals compatible with the membrane elements and components. Use of such chemicals may void the element limited warranty.
- Permeate pressure must always be equal or less than the feed/concentrate pressure. Damage caused by permeate back pressure voids the element limited warranty.

CSM 8" Membranes



Ref. MCRE8040-UL

RE8040-UL

Low pressure grade RO element for ultra pure water

CSM[®]

SPECIFICATIONS:

General Features	Permeate flow rate:	10,000 GPD (37.9 m ³ /day)
	Nominal salt rejection:	99.5%
	Effective membrane area:	400 ft ² (37.2 m ²)

1. The stated product performance is based on data taken after 30 minutes of operation at the following test conditions:

- 1,500 mg/L NaCl solution at 150 psig (1.0 MPa) applied pressure
- 15% recovery
- 77 °F (25 °C)
- pH 6.5–7.0

2. IPA rejection is 92.0% after 2 hours of operation at the following test conditions:

- 1,000 mg/L IPA solution at 225 psig (1.5 MPa) applied pressure
- 15% recovery
- 77 °F (25 °C)
- pH 6.5–7.0

3. Minimum salt rejection is 98.5%.

4. Permeate flow rate for each element may vary but will be no more than 10% below the value shown.

5. All elements are vacuum sealed in a polyethylene bag containing 1.0% SBS (sodium bisulfite) solution and individually packaged in a cardboard box.

Membrane type:	Thin-Film Composite
Membrane material:	Polyamide (PA)
Element configuration:	Spiral-Wound, FRP Wrapping

Dimensions A = 40.0 inch (1,016 mm) B = 8.0 inch (203 mm) C = 1.12 inch (28 mm)



1. Each membrane element comes with one brine seal, one interconnector (coupler) and two o-rings.
2. All RE8040 elements fit nominal 8.0 inch (203 mm) I.D. pressure vessels.

The information provided in this document is solely for informative purposes. It is the user's responsibility to ensure the appropriate usage of this product. Woongjin Chemical assumes no obligation, liability or damages incurred for the misuse of the product or for the information provided in this document. This document does not express or imply any warranty as to the merchantability or fitness of the product.



RE8040-UL

Low pressure grade RO element for ultra pure water

CSM[®]

APPLICATION DATA:

Operating Limits

· Max. Pressure Drop / Element	15 psi (0.1 MPa)
· Max. Pressure Drop / 240" Vessel	60 psi (0.41 MPa)
· Max. Operating Pressure	600 psi (4.14 MPa)
· Max. Feed Flow Rate	66 gpm (15.0 m ³ /hr)
· Min. Concentrate Flow Rate	16 gpm (3.6 m ³ /hr)
· Max. Operating Temperature	113 °F (45 °C)
· Operating pH Range	3.0–10.0
· CIP pH Range	2.0–11.0
· Max. Turbidity	1.0 NTU
· Max. SDI (15 min)	5.0
· Max. Chlorine Concentration	< 0.1 mg/L

Design Guidelines for Various Water Sources

· Wastewater Conventional (SDI < 5)	8–12 gfd
· Wastewater Pretreated by UF/MF (SDI < 3)	10–14 gfd
· Seawater, Open Intake (SDI < 5)	7–10 gfd
· Seawater, Beach Well (SDI < 3)	8–12 gfd
· Surface Water (SDI < 5)	12–16 gfd
· Surface Water (SDI < 3)	13–17 gfd
· Well water (SDI < 3)	13–17 gfd
· RO permeate (SDI < 1)	21–30 gfd

Saturation Limits (Using Antiscalants)[†]

· Langlier Saturation Index (LSI)	<+1.5
· Stiff and Davis Saturation Index (SDSI)	<+0.5
· CaSO ₄	230% saturation
· SrSO ₄	800% saturation
· BaSO ₄	6,000% saturation
· SiO ₂	100% saturation

[†]The above saturation limits are typically accepted by proprietary antiscalant manufacturers. It is the user's responsibility to ensure proper chemical(s) and concentration are dosed ahead of the membrane system to prevent scale formation anywhere within the membrane system. Membrane elements fouled or damaged due to scale formation are not covered by the limited warranty.

GENERAL HANDLING PROCEDURES

- Elements contained in the boxes must be kept dry at room temperature (7–32°C; 40–95°F) and should not be stored in direct sunlight. If the polyethylene bag is damaged, a new preservative solution (sodium bisulfite) must be added and air-tight sealed to prevent drying and biological growth.
- Permeate from the first hour of operation should be discarded to flush out the preservative solution.
- Elements should be immersed in a preservative solution during storage, shipping and system shutdowns to prevent biological growth and freezing. The standard storage solution contains 1% by weight sodium bisulfite or sodium metabisulfite (food grade). For short term storage (i.e. one week or less) 1% by weight sodium metabisulfite solution is adequate for preventing biological growth.
- Keep elements moist at all times after initial wetting.
- Avoid excessive pressure and flow spikes.
- Only use chemicals compatible with the membrane elements and components. Use of such chemicals may void the element limited warranty.
- Permeate pressure must always be equal or less than the feed/concentrate pressure. Damage caused by permeate back pressure voids the element limited warranty.

CSM 8" Membranes



Ref. MCUE8040-PF

UE8040-PF

Normal grade UF element for RO pretreatment

CSM[®]

SPECIFICATIONS:

General Features	Permeate flow rate:	14,000 GPD (52.9 m ³ /day)
	Molecular Weight Cut Off:	50K–100K (Daltons)
	Effective membrane area:	400 ft ² (37.2 m ²)

1. The stated product performance is based on data taken after 30 minutes of operation at the following test conditions:

- **Concentration: pure water**
- **Pressure: 20 psig**
- **77 °F (25 °C)**
- **pH 6.5–7.0**

2. Permeate flow rate for each element may vary but will be no more than 20%.

3. All elements are vacuum sealed in a polyethylene bag containing 1.0% SBS (sodium bisulfite) solution and individually packaged in a cardboard box.

Membrane type:	Thin-Film Composite
Membrane material:	Polysulfone (PSF)
Element configuration:	Spiral-Wound, FRP Wrapping

Dimensions and Weight

Model Name	A	B	C	Weight	Part Number	
					Inter-connector	Brine Seal
UE8040-PF	40.0 inch (1,016 mm)	8.0 inch (201 mm)	1.12 inch (28 mm)	15 kg	40000308	40000309



1. Each membrane element supplied with one brine seal, one interconnector (coupler) and four o-rings.
2. All UE8040 elements fit nominal 8.0 inch (201 mm) I.D. pressure vessels.

The information provided in this document is solely for informative purposes. It is the user's responsibility to ensure the appropriate usage of this product. Woongjin Chemical assumes no obligation, liability or damages incurred for the misuse of the product or for the information provided in this document. This document does not express or implies any warranty as to the merchantability or fitness of the product.



UE8040-PF

Normal grade UF element for RO pretreatment

CSM[®]

APPLICATION DATA:

Operating Limits

· Max. Pressure Drop / Element	15 psi (0.1 MPa)
· Max. Pressure Drop / 240" Vessel	60 psi (0.41 Mpa)
· Max. Operating Pressure	600 psi (4.14 MPa)
· Max. Feed Flow Rate	75 gpm (17.0 m ³ /hr)
· Min. Concentrate Flow Rate	16 gpm (3.6 m ³ /hr)
· Max. Operating Temperature	113 °F (45 °C)
· Operating pH Range	2.0–11.0
· CIP pH Range	1.0–13.0
· Max. Turbidity	1.0 NTU
· Max. SDI (15 min)	5.0

Design Guidelines for Various Water Sources

· Surface Water (SDI < 5)	10–15 gfd
· Softened Water (SDI < 3)	15–20 gfd
· RO permeate (SDI < 1)	21–30 gfd

GENERAL HANDLING PROCEDURES

- Elements contained in the boxes must be kept dry at room temperature (7–32°C; 40–95°F) and should not be stored in direct sunlight. If the polyethylene bag is damaged, a new preservative solution (sodium bisulfite) must be added and air-tight sealed to prevent drying and biological growth.
- Permeate from the first hour of operation should be discarded to flush out the preservative solution.
- Elements should be immersed in a preservative solution during storage, shipping and system shutdowns to prevent biological growth and freezing. The standard storage solution contains 1% by weight sodium bisulfite or sodium metabisulfite (food grade). For short term storage (i.e. one week or less) 1% by weight sodium metabisulfite solution is adequate for preventing biological growth.
- Keep elements moist at all times after initial wetting.
- Avoid excessive pressure and flow spikes.
- Only use chemicals compatible with the membrane elements and components. Use of such chemicals may void the element limited warranty.
- Permeate pressure must always be equal or less than the feed/concentrate pressure. Damage caused by permeate back pressure voids the element limited warranty.

CSM Membranes Brine Seal and Interconnector



- Each membrane element supplied with one brine seal and one interconnector (excepted for 2,5" membrane element, supplied without interconnector).

BRINE SEAL				
REF.	DESCRIPTION	MATERIAL	FOR MEMBRANES	
DC005	EPDM BRINE SEAL 2.5" CSM	EPDM	2,5"	
DD003	EPDM BRINE SEAL 4" CSM	EPDM	4"	
EA798	EPDM BRINE SEAL 8" CSM	EPDM	8"	

INTERCONNECTOR					
REF.	DESCRIPTION	MATERIAL	COLOR	FOR MEMBRANES	
DD004	ABS FEMALE INTERCONNECTOR CSM 2.5" & 4" WITH O-RING	ABS	WHITE	2,5" – 4"	
EA797	ABS MALE INTERCONNECTOR 1.5" CSM WITH O-RING	ABS	WHITE	8"	
EA799	ABS MALE INTERCONNECTOR 1.125" CSM WITH O-RING -BW TYPE	ABS	BLACK	8"	
EA800	NORYL MALE INTERCONNECTOR 1.125" CSM WITH O-RING - SW TIPE	NORYL	BLACK	8"	

Antiscaling for R. O. Membranes Permascale Eut 110



- PERMASCALE EUT110 is a product that prevents scales and iron sediment on R.O. membranes systems;
- for industrial systems and for potable water treatment systems;
- very effective on various kinds of water, minimize the fouling and reduce the frequency of membranes cleaning;
- particularly suitable for big plants with permeate flows higher than 100 m³/day;
- compatible with all kinds of membranes;
- replace totally or partially the acidification;
- easy to use due to the liquid form.

Characteristics	
Formulation	special phosphonated
pH	7,8 ± 0,5
Appearance	light yellow liquid
Density @ 20°C	1,30 ± 0,05 g/ml
Checking	phosphonated value
Solubility in water	complete

REF.	
EA100	

Use

Injection by dosing pump of pure or diluted product.

The dosage is according to the concentration of scaling salts and iron, and can vary from 2 to 10 cm³/m³ of feed water.

Instructions and Packaging

Handling: following safety data sheet. Take the normal precautions to handle chemical products.

Packaging: 25 kg drum.

Storage: closed on the original packaging, sheltered from cold and heat.

Antiscaling for R.O. Membranes

Permascale EUT 120



- PERMASCALE EUT120 is a product that prevents scales and iron sediment on R.O. membranes systems;
- very effective on various kinds of water, minimize the fouling and reduce the frequency of membranes cleaning;
- particularly suitable for plants with permeate flows lower than 100 m³/day;
- compatible with all kinds of membranes;
- replace totally or partially the acidification;
- easy to use due to the liquid form.

Characteristics	
Formulation	special phosphonated
pH	7,5 ± 0,5
Appearance	light yellow liquid
Density @ 20°C	1,30 ± 0,02 g/ml
Checking	phosphonated value
Solubility in water	complete

REF.	
EA101	

Use

Injection by dosing pump of pure or diluted product.

The dosage is according to the concentration of scaling salts and iron, and can vary from 3 to 13 cm³/m³ of feed water.

Instructions and Packaging

Handling : following safety data sheet. Take the normal precautions to handle chemical products.

Packaging: 25 kg drum.

Storage: closed on the original packaging, sheltered from cold and heat.

Antiscaling for R. O. Membranes PermaTreat PC-391T



- PermaTreat PC-391T is recommended for systems that produce less than 545 m³/day (100 GPM) of permeate. This program is less concentrated than PermaTreat PC-191T and, therefore, offers the benefits and advantages of neat feed for smaller RO systems;
- PermaTreat PC-391T has exhibited excellent performance against the following foulants: calcium carbonate, calcium sulfate, barium sulfate, strontium sulfate and iron;
- Packaging: 25 kg drum.

Physical & Chemical Properties	
Color	Clear, yellow
Form	Liquid
Odor	Slight ammonia smell
Specific gravity @ 25°C	1,10
pH (Neat)	10,8
Solubility in water	Complete

REF.	
EA102 (*)	

(*) not available in stock.

Compatible Materials

Stainless Steel 304, CPVC Piping, Polyethylene, Polypropylene, Plasite 4300 and Plasite 7122.

All membrane elements based on Polyamide chemistries including Thin Film Composite (TFC) membranes when used as directed.

Not Compatible Materials

Neoprene, Hypalon elastomer, Buna-N and EPDM: P.S. for all these materials, O-rings are acceptable for static applications. If the fitting is opened, O-ring must be replaced.

Brass, Polyurethane and Viton.

Dosage and Feeding

PermaTreat PC-391T must be fed continuously. The feedpoint location should be as close to the RO membrane as practical but one that ensures good mixing with the feedwater prior to entering the RO system.

PermaTreat PC-391T dosage is dependent on feedwater chemistry, membrane type, system operating parameters (e.g., recovery, temperature and pressure). These parameters determine the potential foulant that is likely to foul the membrane elements.

Please, consult our Technical Department for detailed dosage and feeding information.

Antiscaling for R. O. Membranes PermaTreat PC-391T



CONSEQUENCES OF OVERFEED

Overfeed of PermaTreat PC-391T will result in higher chemical cost.

CONSEQUENCES OF UNDERFEED

Underfeed of PermaTreat PC-391T will result in poor scale inhibition. This will lead to fouled RO membranes and reduce system performance and/or premature membrane replacement. In RO units, scaling is typically seen in the tail-end elements that have the highest reject concentration (4:1 for a 75% recovery system).

Please, consult our Technical Department for detailed dosage and feeding information.

ENVIRONMENTAL AND TOXICITY DATA

Refer to the MSDS for all available mammalian and aquatic toxicity information.

	ppm/ppm product
Biological Oxygen Demand (5-day BOD ₅)	Not Available
Chemical Oxygen Demand (COD)	Not Available
Total Organic Carbon (TOC)	Not Available

SAFETY AND HANDLING

Before using PermaTreat PC-391T, please refer to the Material Safety Data Sheet (MSDS) for proper personal protective equipment (PPE) and for health effects.

STORAGE

PermaTreat PC-391T has a suggested in-plant storage limit of one year. The suggested maximum storage temperature is 38°C.

Refer to the (MSDS) for the most current data.

REMARKS

For Medical and Transportation Emergencies, please see the MSDS.

Antiscaling for R. O. Membranes PermaTreat PC-191T



- PermaTreat PC-191T is a highly effective scale inhibitor whose active components were developed to treat reverse osmosis (RO) systems;
- PermaTreat PC-191T has shown excellent performance against the following scalants: calcium carbonate, calcium sulfate, barium sulfate, strontium sulfate, calcium fluoride, silica and iron;
- **For RO units with a feedwater flowrate of 545 m³/day (100 GPM) or less, the recommended product would be PermaTreat PC-391T (our ref. EA102);**
- PermaTreat PC-191T is used when the silica level in the brine is less than 185 mg/l at a brine pH of 7,5 and temperature 25°C;
- Packaging: 25 kg drum.

Physical & Chemical Properties	
Color	Clear, yellow
Form	Liquid
Odor	Slight ammonia smell
Specific gravity @ 25°C	1,36
pH (Neat)	10,5
Solubility in water	Complete

REF.	
EA103 (*)	

(*) not available in stock.

Compatible Materials

Stainless Steel 304, CPVC Piping, Polyethylene, Polypropylene, Plasite 4300 and Plasite 7122.

All membrane elements based on Polyamide chemistries including Thin Film Composite (TFC) membranes when used as directed.

Not Compatible Materials

Neoprene, Hypalon elastomer, Buna-N and EPDM: P.S. for all these materials, O-rings are acceptable for static applications. If the fitting is opened, O-ring must be replaced.

Brass, Polyurethane and Viton.

Dosage and Feeding

PermaTreat PC-191T must be fed continuously. The feedpoint location should be as close to the RO membrane as practical but one that ensures good mixing with the feedwater prior to entering the RO system.

PermaTreat PC-191T dosage is dependent on feedwater chemistry, membrane type, system operating parameters (e.g., recovery, temperature and pressure). These parameters determine the potential foulant that is likely to foul the membrane elements.

Please, consult our Technical Department for detailed dosage and feeding information.

Antiscaling for R. O. Membranes PermaTreat PC-191T



CONSEQUENCES OF OVERFEED

Overfeed of PermaTreat PC-191T will result in higher chemical cost.

CONSEQUENCES OF UNDERFEED

Underfeed of PermaTreat PC-191T will result in poor scale inhibition. This will lead to fouled RO membranes and reduce system performance and/or premature membrane replacement. In RO units, scaling is typically seen in the tail-end elements that have the highest reject concentration (4:1 for a 75% recovery system).

Please, consult our Technical Department for detailed dosage and feeding information.

ENVIRONMENTAL AND TOXICITY DATA

Refer to the MSDS for all available mammalian and aquatic toxicity information.

	ppm/ppm product
Biological Oxygen Demand (5-day BOD ₅)	Not Available
Chemical Oxygen Demand (COD)	Not Available
Total Organic Carbon (TOC)	Not Available

SAFETY AND HANDLING

Before using PermaTreat PC-191T, please refer to the Material Safety Data Sheet (MSDS) for proper personal protective equipment (PPE) and for health effects.

STORAGE

PermaTreat PC-191T has a suggested in-plant storage limit of one year. The suggested maximum storage temperature is 38°C.

Refer to the (MSDS) for the most current data.

REMARKS

For Medical and Transportation Emergencies, please see the MSDS.



Vessels,
accessories,
rotary pumps



2 ½" Membrane Vessels End Port Series 300 E-2.5



- fiberglass reinforced plastic pressure vessels series 300 E-2.5, D.75" direct connection, white painted, UVA-ray proof material;
- end-cap in ABS;
- max operating pressure 300 psi (21 bar);
- European 97/23/EC Directive compliant for pressure equipment (PED);
- built in accordance with ASME code section X;
- D.M. n.174 dated 06/04/2004 compliant about materials suitable for contact with water for human consumption;
- each vessel is factory tested at 1,5 times max operating pressure;
- connections: feed/concentrate ¼" BSPT F, permeate ¼" BSPT F;
- straps and saddles included.

REF.	MODEL	ELEMENTS	L (mm)	S (mm)	
H2E1BQ	300 E – 2514	1 x 14"	431	200	
H2E1BV	300 E – 2521	1 x 21"	609	400	
H2E1B1	300 E – 2.5 – 1	1 x 40"	1092	700	

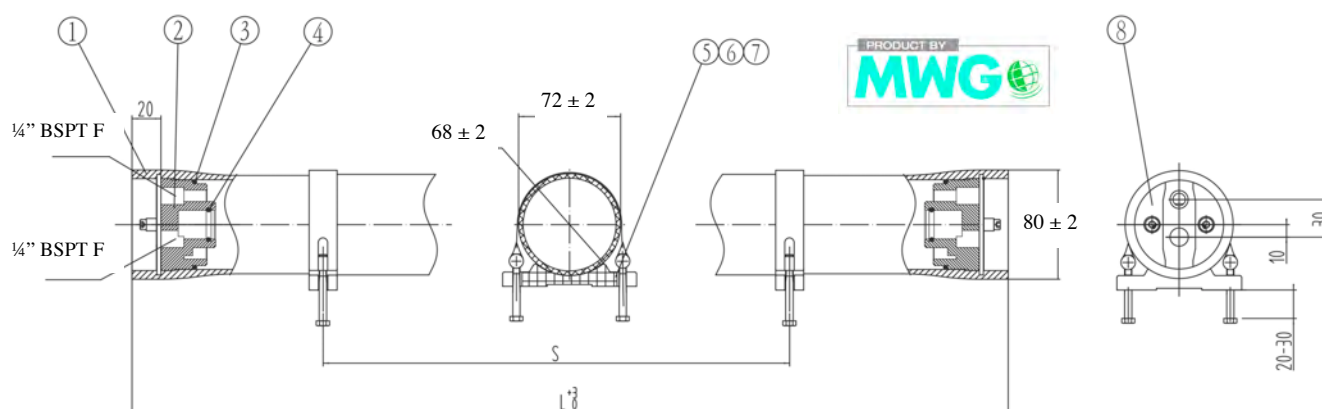

SPARE PARTS

ITEM	REF.	DESCRIPTION	Q.TY	MATERIAL	REMARK
1		Pressure Shell	1	Epoxy FRP	White
2 + 4	H2R011	End Plate	2	ABS	
3	H2R103	Head Seal	2	EPDM	56x3,55
4	H2R101	Adapter Seal	2	EPDM	19x2,65
5	H2R001	Saddle	2	Rubber	
6	H2R201	Strap Screw	4	AISI 304	M6x60
7	H2R003	Strap	2	AISI 304 - rubber	
8	H2R041	Seeger	4	AISI 304	

2 ½” Membrane Vessels End Port Series 1000 E-2.5



- fiberglass reinforced plastic pressure vessels series 1000 E-2.5, D.75” direct connection, white painted, UVA-ray proof material;
- end-cap in super duplex steel AISI 2507;
- max operating pressure 1000 psi (69 bar);
- European 97/23/EC Directive compliant for pressure equipment (PED);
- built in accordance with ASME code section X;
- D.M. n.174 dated 06/04/2004 compliant about materials suitable for contact with water for human consumption;
- each vessel is factory tested at 1,5 times max operating pressure;
- connections: feed/concentrate ¼” BSPT F, permeate ¼” BSPT F;
- straps and saddles included.

REF.	MODEL	ELEMENTS	L (mm)	S (mm)	
H2E1GV	1000 E – 2521	1 x 21”	629	400	
H2E1G1	1000 E – 2.5 – 1	1 x 40”	1112	700	

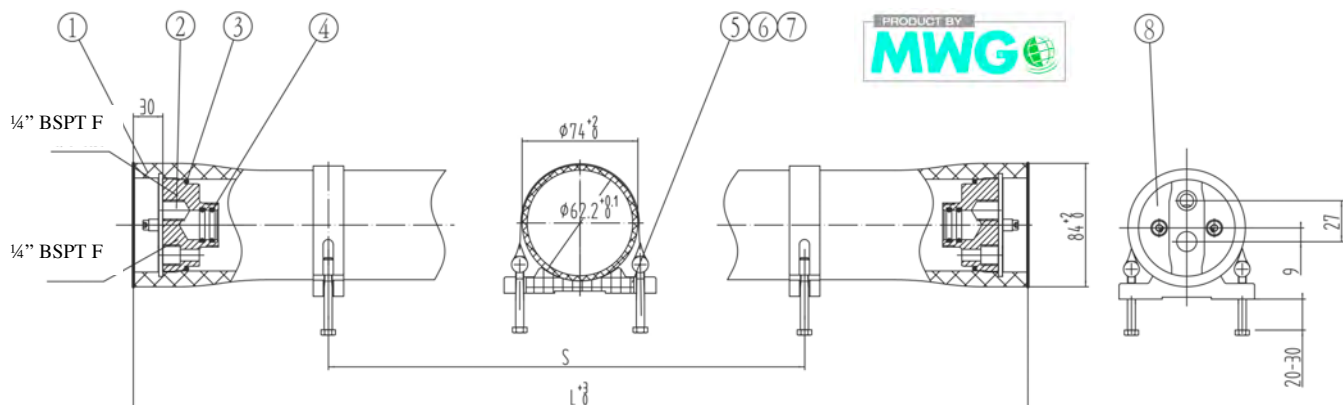

SPARE PARTS						
Item	Ref.	Description	Quantity	Material	Remark	
1		Pressure Shell	1	Epoxy FRP	White	
2 + 4	H2R013	End Plate	2	Super Duplex Steel AISI 2507		
3	H2R103	Head Seal	2	EPDM	56x3,55	
4	H2R101	Adapter Seal	4	EPDM	19x2,65	
5	H2R001	Saddle	2	Rubber		
6	H2R201	Strap Screw	4	AISI 304	M6x60	
7 + 6	H2R005	Strap	2	AISI 304 - Rubber		
8	H2R041	Seeger	4	AISI 316		

4" Membrane Vessels End Port Series 300 E-4



- fiberglass reinforced plastic pressure vessels series 300 E-4, D.75" direct connection, white painted, UVA-ray proof material;
- end-cap in ABS;
- max operating pressure 300 psi (21 bar);
- European 97/23/EC Directive compliant for pressure equipment (PED);
- built in accordance with ASME code section X;
- D.M. n.174 dated 06/04/2004 compliant about materials suitable for contact with water for human consumption;
- each vessel is factory tested at 1,5 times max operating pressure;
- permeate connections ½" BSPT F;
- straps and saddles included (n.2 pcs from 1 to 3 elements, n.3 pcs from 4 to 6 elements).

REF.	MODEL	ELEMENTS	L (mm)	S (mm)	CONNECTIONS FEED / CONCENTRATE	
H4E2BV	300 E – 4021	1 x 21"	658	400	½" BSPT F	
H4E3BV	300 E – 4021	1 x 21"	658	400	¾" BSPT F	
H4E2B1	300 E – 4 – 1	1 x 40"	1140	600	½" BSPT F	
H4E3B1	300 E – 4 – 1	1 x 40"	1140	600	¾" BSPT F	
H4E2B2	300 E – 4 – 2	2 x 40"	2156	1200	½" BSPT F	
H4E3B2	300 E – 4 – 2	2 x 40"	2156	1200	¾" BSPT F	
H4E2B3	300 E – 4 – 3	3 x 40"	3172	2200	½" BSPT F	
H4E3B3	300 E – 4 – 3	3 x 40"	3172	2200	¾" BSPT F	
H4E2B4 (*)	300 E – 4 – 4	4 x 40"	4268	1600x2	½" BSPT F	
H4E3B4 (*)	300 E – 4 – 4	4 x 40"	4268	1600x2	¾" BSPT F	
H4E2B5 (*)	300 E – 4 – 5	5 x 40"	5284	2300x2	½" BSPT F	
H4E3B5 (*)	300 E – 4 – 5	5 x 40"	5284	2300x2	¾" BSPT F	
H4E2B6 (*)	300 E – 4 – 6	6x 40"	6300	2700x2	½" BSPT F	
H4E3B6 (*)	300 E – 4 – 6	6 x 40"	6300	2700x2	¾" BSPT F	

(*) not available in stock – Delivery 8-10 weeks.

4" Membrane Vessels End Port Series 300 E-4

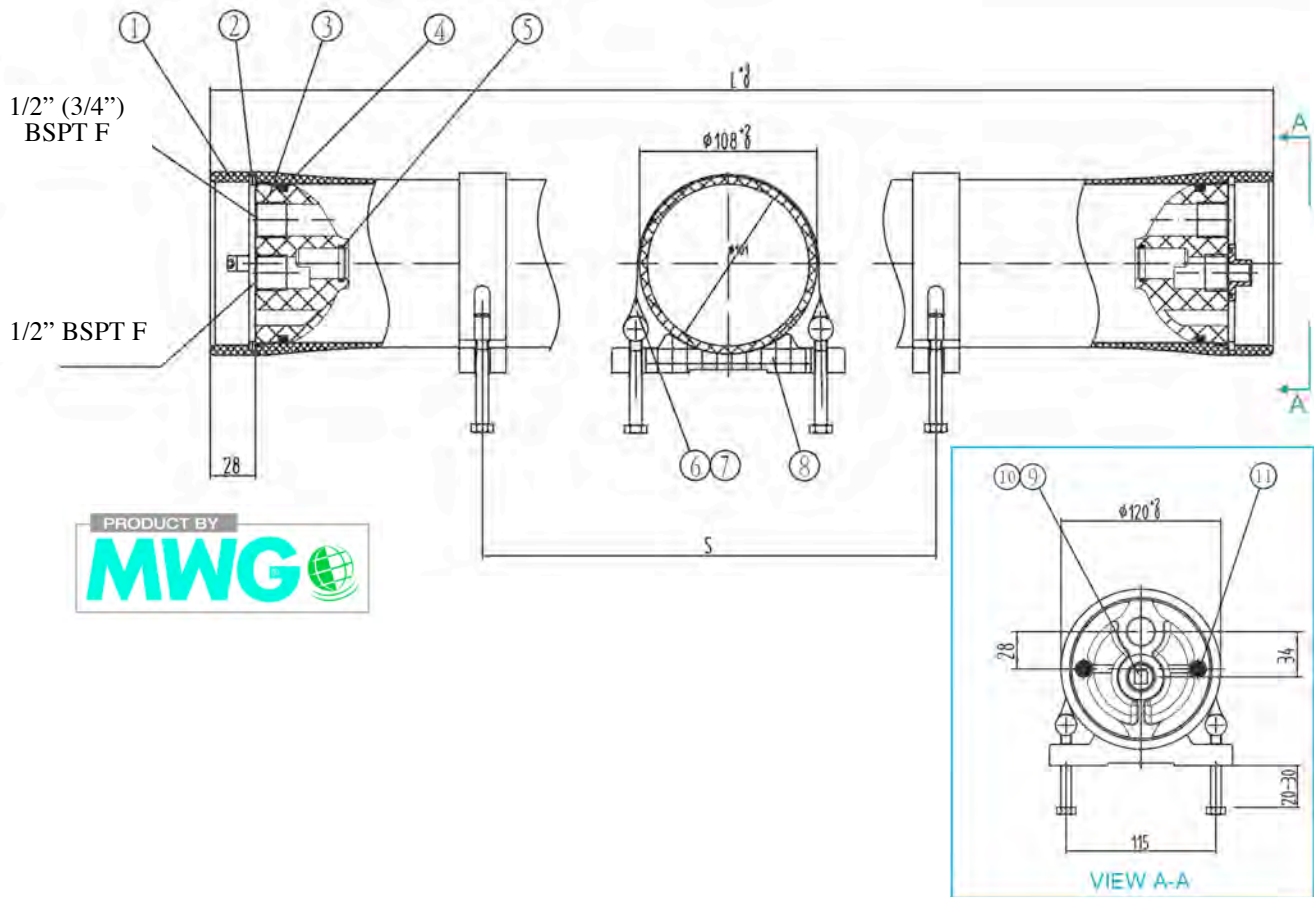

SPARE PARTS						
Item	Ref.	Description	Quantity	Material	Remark	
1		Pressure Shell	1	Epoxy FRP	White	
2	H4R041	Seeger	4	AISI 304		
3 + 5	H4R401	End Plate	2	ABS	1/2" 1/2"	
	H4R403	End Plate	2	ABS	3/4" 1/2"	
4	H4R107	Head Seal	2	EPDM	90x5,3	
5	H2R101	Adapter Seal	2	EPDM	19x2,65	
6 + 7	H4R003	Strap	2-3	AISI 304 - Rubber		
7	H4R201	Strap Screw	4-6	AISI 304	M8x70	
8	H4R001	Saddle	2-3	Rubber		
9	H4R081	Plug	1	ABS		
10	H4R101	O-ring of Plug	1	EPDM	23,6x3,55	
11	H4R209	Seeger Screw	4	AISI 304	M6x14	

4" Membrane Vessels End Port Series 450 E-4



- fiberglass reinforced plastic pressure vessels series 450 E-4, D.75" direct connection, white painted, UVA-ray proof material;
- end-cap in ABS;
- max operating pressure 450 psi (31 bar);
- European 97/23/EC Directive compliant for pressure equipment (PED);
- built in accordance with ASME code section X;
- D.M. n.174 dated 06/04/2004 compliant about materials suitable for contact with water for human consumption;
- each vessel is factory tested at 1,5 times max operating pressure;
- permeate connections ½" BSPT F;
- straps and saddles included (n.2 pcs from 1 to 3 elements, n.3 pcs from 4 to 6 elements).

REF.	MODEL	ELEMENTS	L (mm)	S (mm)	CONNECTIONS FEED / CONCENTRATE	
H4E2CV	450 E – 4021	1 x 21"	670	400	½" Rc F	
H4E2C1	450 E – 4 – 1	1 x 40"	1152	600	½" Rc F	
H4E3C1	450 E – 4 – 1	1 x 40"	1152	600	¾" Rc F	
H4E2C2	450 E – 4 – 2	2 x 40"	2168	1200	½" Rc F	
H4E3C2	450 E – 4 – 2	2 x 40"	2168	1200	¾" Rc F	
H4E2C3	450 E – 4 – 3	3 x 40"	3184	2200	½" Rc F	
H4E3C3	450 E – 4 – 3	3 x 40"	3184	2200	¾" Rc F	
H4E2C4 (*)	450 E – 4 – 4	4 x 40"	4280	1600x2	½" Rc F	
H4E3C4 (*)	450 E – 4 – 4	4 x 40"	4280	1600x2	¾" Rc F	
H4E2C5 (*)	450 E – 4 – 5	5 x 40"	5296	2300x2	½" Rc F	
H4E3C5 (*)	450 E – 4 – 5	5 x 40"	5296	2300x2	¾" Rc F	
H4E2C6 (*)	450 E – 4 – 6	6 x 40"	6312	2700x2	½" Rc F	
H4E3C6 (*)	450 E – 4 – 6	6 x 40"	6312	2700x2	¾" Rc F	

(*) not available in stock – Delivery 8-10 weeks.

4" Membrane Vessels End Port Series 450 E-4

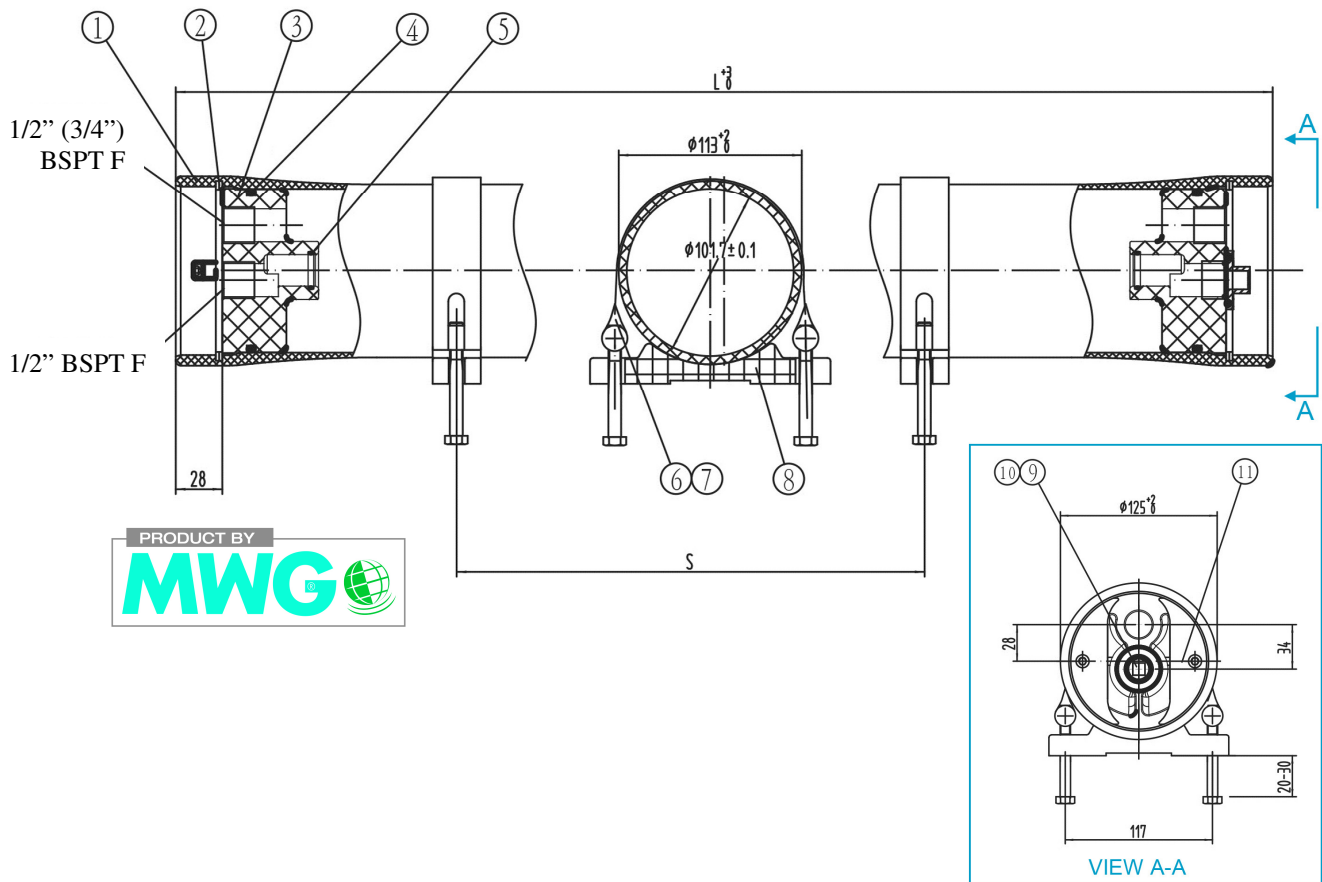

SPARE PARTS

ITEM	REF.	DESCRIPTION	Q.TY	MATERIAL	REMARK	
1		Pressure Shell	1	Epoxy FRP	White	
2	H4R041	Seeger	4	AISI 304		
3 + 5	H4R401	End Plate	2	ABS	1/2" 1/2"	
	H4R403	End Plate	2	ABS	3/4" 1/2"	
4	H4R107	Head Seal	2	EPDM	90x5,3	
5	H2R101	Adapter Seal	2	EPDM	19x2,65	
6 + 7	H4R003	Strap	2-3	AISI 304 - Rubber		
7	H4R201	Strap Screw	4-6	AISI 304	M8x70	
8	H4R001	Saddle	2-3	Rubber		
9	H4R081	Plug	1	ABS		
10	H4R101	O-ring of Plug	1	EPDM	23,6x3,55	
11	H4R209	Seeger Screw	4	AISI 304	M6x14	

4" Membrane Vessels End Port Series 600 E-4



- fiberglass reinforced plastic pressure vessels series 600 E-4, complete with 0,75" adapters, white painted, UVA-ray proof material;
- max operating pressure 600 psi (41 bar);
- European 97/23/EC Directive compliant for pressure equipment (PED);
- built in accordance with ASME code section X;
- D.M. n.174 dated 06/04/2004 compliant about materials suitable for contact with water for human consumption;
- each vessel is factory tested at 1,5 times max operating pressure;
- feed/concentrate connections ¾" BSPT M, in super duplex steel AISI 2507;
- permeate connections ½" BSPT M;
- straps and saddles included (n.2 pcs from 1 to 3 elements, n.3 pcs from 4 to 6 elements).

(* not available in stock – Delivery 8-10 weeks.

REF.	MODEL	ELEMENTS	L (mm)	S (mm)	
H4E4DV	600 E-4021	1 x 21"	762	400	
H4E4D1	600 E-4-1	1 x 40"	1244	600	
H4E4D2 (*)	600 E-4-2	2 x 40"	2260	1200	
H4E4D3 (*)	600 E-4-3	3 x 40"	3276	2200	
H4E4D4 (*)	600 E-4-4	4 x 40"	4372	1600x2	

SPARE PARTS:

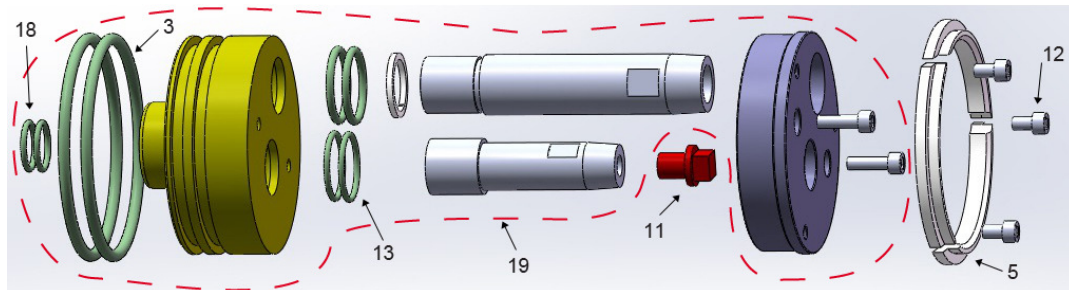

ITEM	REF.	DESCRIPTION	Q.TY	MATERIAL	REMARK	
3	H4R107	Head Seal	4	EPDM	90x5,3	
5	H4R045	Locking Kit (n.3 Segments)	2	AISI 316		
11	H4R083	Plug	1	ABS		
12	H4R205	Securing Screw	6	AISI 304	M6x20	
13	H4R111	O-ring of Permeate Port	4	EPDM	25x2,65	
14 + 15	H4R005	Strap	2-3	AISI 304 - Rubber		
15	H4R201	Strap Screw	4-6	AISI 304	M8x70	
16	H4R001	Saddle	2-3	Rubber		
18	H2R101	Adapter Seal	4	EPDM	19x2,65	
19	H4R707	Head Assembly end port	2			

4" Membrane Vessels End Port Series 600 E-4

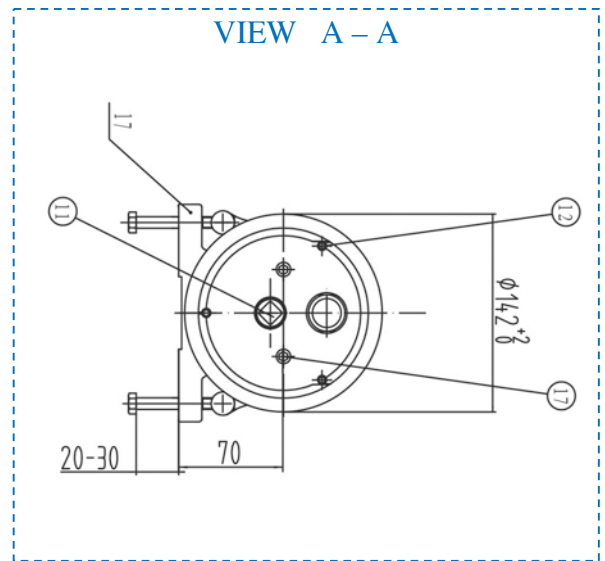
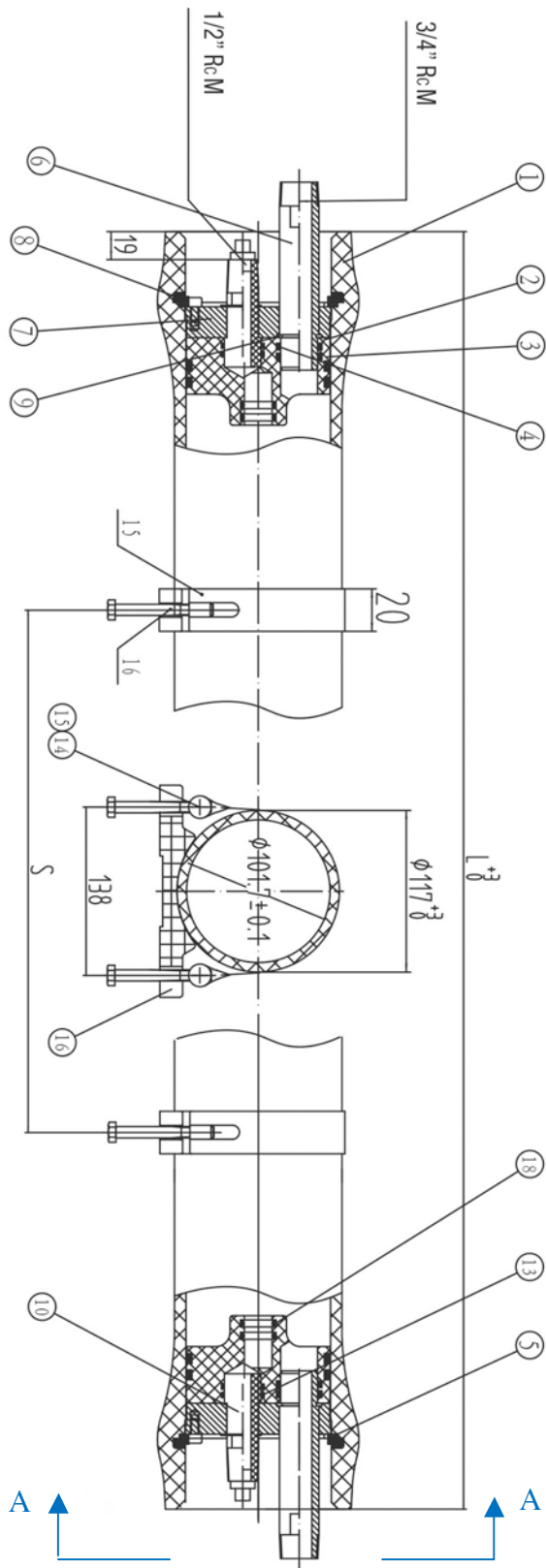

4" Membrane Vessels End Port Series 1000 E-4



- fiberglass reinforced plastic pressure vessels series 1000 E-4, complete with 0,75" adapters, white painted, UVA-ray proof material;
- max operating pressure 1000 psi (69 bar);
- European 97/23/EC Directive compliant for pressure equipment (PED);
- built in accordance with ASME code section X;
- D.M. n.174 dated 06/04/2004 compliant about materials suitable for contact with water for human consumption;
- each vessel is factory tested at 1,5 times max operating pressure;
- feed/concentrate connections ¾" BSPT M, in super duplex steel AISI 2507;
- permeate connections ½" BSPT M;
- straps and saddles included (n.2 pcs from 1 to 3 elements, n.3 pcs from 4 to 6 elements).

(*) not available in stock – Delivery 8-10 weeks.

REF.	MODEL	ELEMENTS	L (mm)	S (mm)	
H4E4GV	1000 E-4021	1 x 21"	762	400	
H4E4G1	1000 E-4-1	1 x 40"	1244	600	
H4E4G2	1000 E-4-2	2 x 40"	2260	1200	
H4E4G3	1000 E-4-3	3 x 40"	3276	2200	
H4E4G4 (*)	1000 E-4-4	4 x 40"	4372	1600x2	
H4E4G5 (*)	1000 E-4-5	5 x 40"	5388	2300x2	
H4E4G6 (*)	1000 E-4-6	6 x 40"	6404	2700x2	

SPARE PARTS:

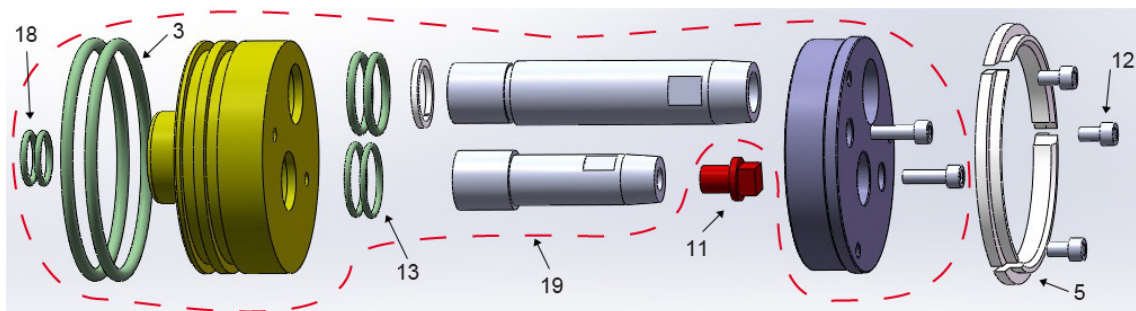

ITEM	REF.	DESCRIPTION	Q.TY	MATERIAL	REMARK	
3	H4R107	Head Seal	4	EPDM	90x5,3	
5	H4R045	Locking Kit (n.3 Segments)	2	AISI 316		
11	H4R083	Plug	1	ABS		
12	H4R205	Securing Screw	6	AISI 304	M6x20	
13	H4R111	O-ring of Permeate Port	4	EPDM	25x2,65	
14 + 15	H4R005	Strap	2-3	AISI 304 - Rubber		
15	H4R201	Strap Screw	4-6	AISI 304	M8x70	
16	H4R001	Saddle	2-3	Rubber		
18	H2R101	Adapter Seal	4	EPDM	19x2,65	
19	H4R707	Head Assembly end port	2			

4" Membrane Vessels End Port Series 1000 E-4

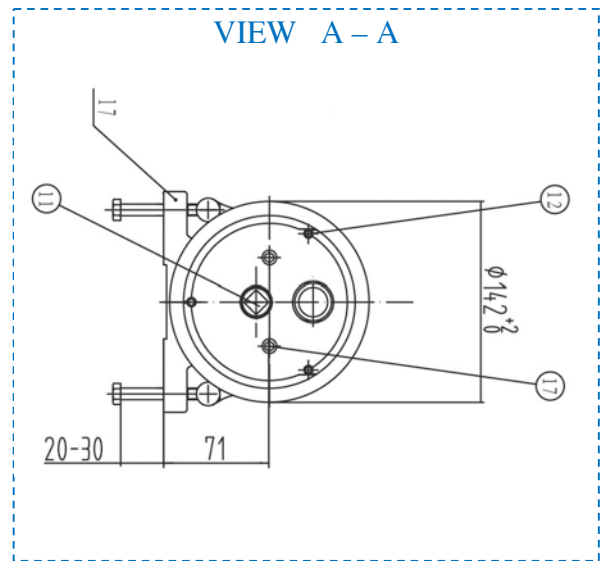
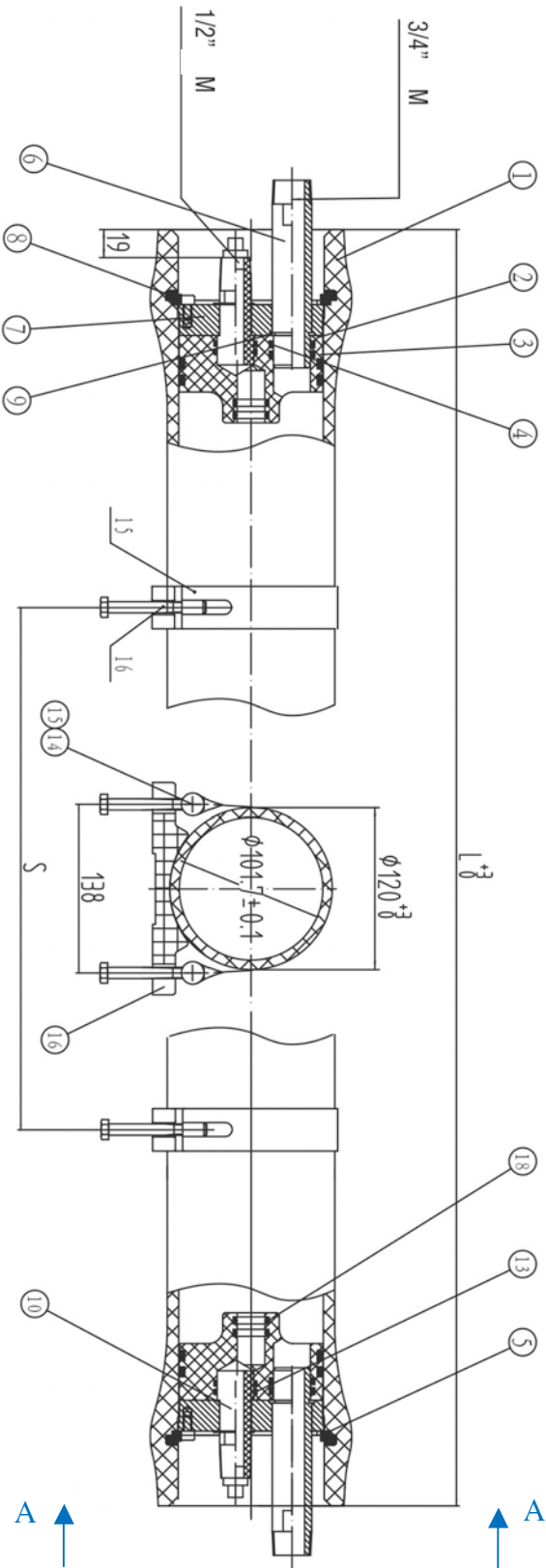

4" Membrane Vessels End Port Series 1200 E-4



- fiberglass reinforced plastic pressure vessels series 1200 E-4, complete with 0,75" adapters, white painted, UVA-ray proof material;
- max operating pressure 1200 psi (83 bar);
- European 97/23/EC Directive compliant for pressure equipment (PED);
- built in accordance with ASME code section X;
- D.M. n.174 dated 06/04/2004 compliant about materials suitable for contact with water for human consumption;
- each vessel is factory tested at 1,5 times max operating pressure;
- feed/concentrate connections ¾" BSPT M, in super duplex steel AISI 2507;
- permeate connections ½" BSPT M;
- straps and saddles included (n.2 pcs from 1 to 3 elements, n.3 pcs from 4 to 6 elements).

(*) not available in stock – Delivery 8-10 weeks.

REF.	MODEL	ELEMENTS	L (mm)	S (mm)	
H4E4H1	1200 E-4-1	1 x 40"	1244	600	
H4E4H2	1200 E-4-2	2 x 40"	2260	1200	
H4E4H3	1200 E-4-3	3 x 40"	3276	2200	
H4E4H4 (*)	1200 E-4-4	4 x 40"	4372	1600x2	
H4E4H5 (*)	1200 E-4-5	5 x 40"	5388	2300x2	
H4E4H6 (*)	1200 E-4-6	6 x 40"	6404	2700x2	

SPARE PARTS:

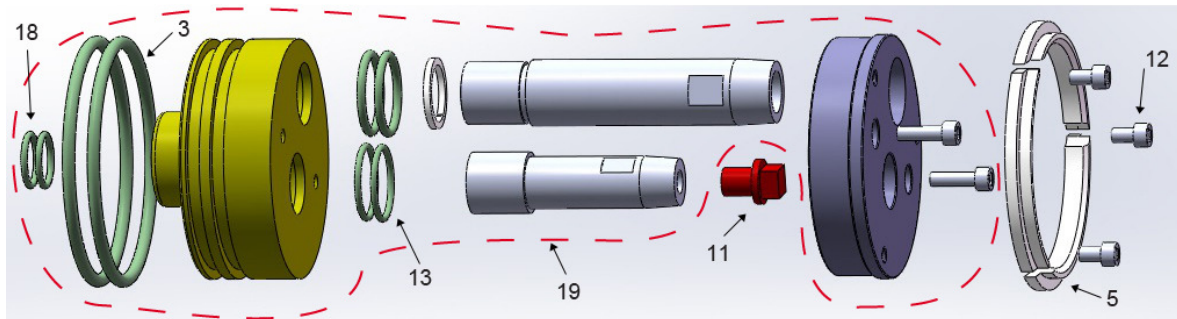

ITEM	REF.	DESCRIPTION	Q.TY	MATERIAL	REMARK	
3	H4R107	Head Seal	4	EPDM	90x5,3	
5	H4R045	Locking Kit (n.3 Segments)	2	AISI 316		
11	H4R083	Plug	1	ABS		
12	H4R205	Securing Screw	6	AISI 304	M6x20	
13	H4R111	O-ring of Permeate Port	4	EPDM	25x2,65	
14 + 15	H4R005	Strap	2-3	AISI 304 - Rubber		
15	H4R201	Strap Screw	4-6	AISI 304	M8x70	
16	H4R001	Saddle	2-3	Rubber		
18	H2R101	Adapter Seal	4	EPDM	19x2,65	
19	H4R707	Head Assembly end port	2			

4" Membrane Vessels End Port Series 1200 E-4

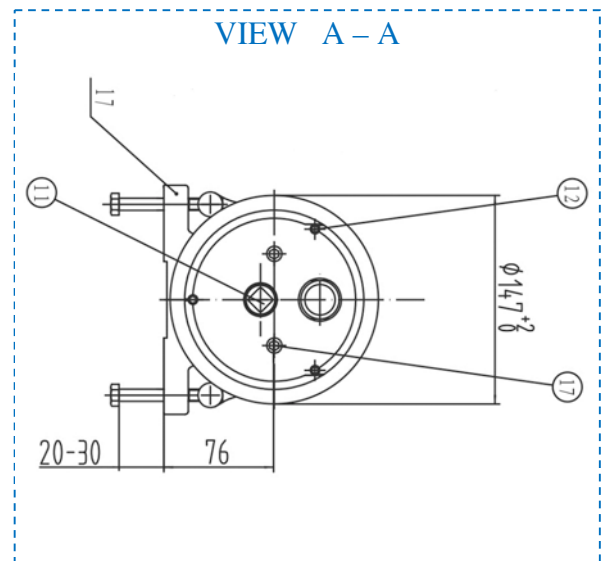
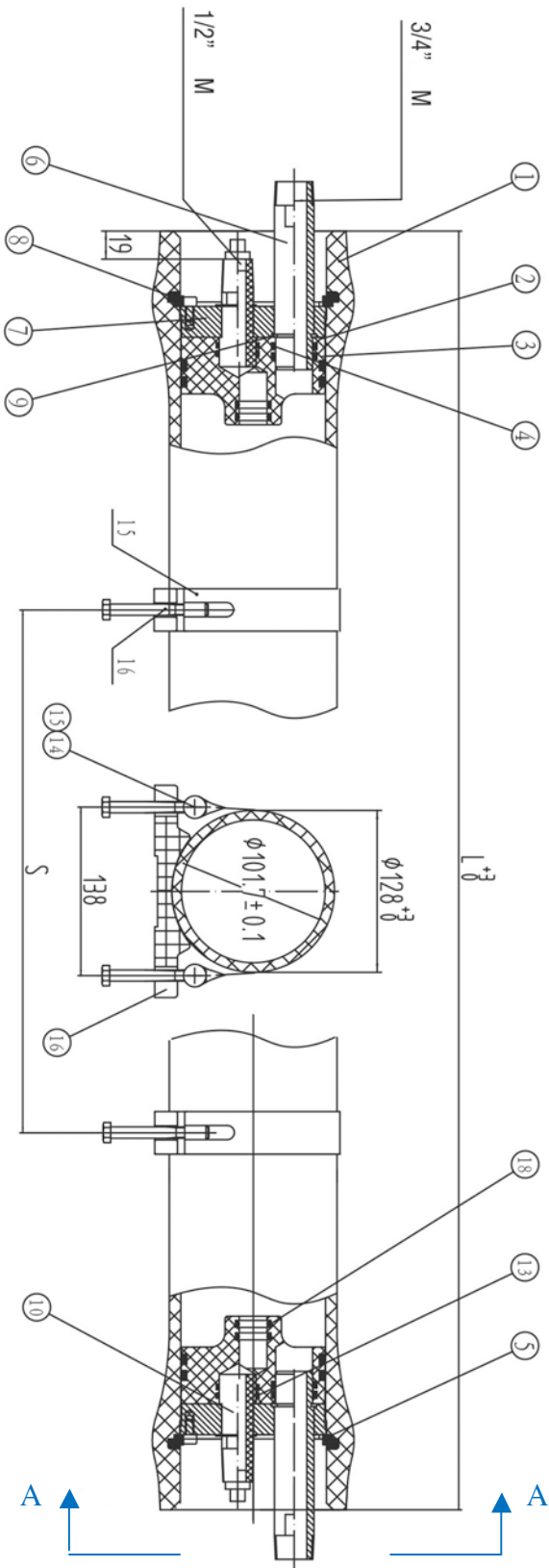

4" Membrane Vessels Side Port Series 300 S-4



- fiberglass reinforced plastic pressure vessels series 300 S-4, D.75" direct connection, white painted, UVA-ray proof material;
- max operating pressure 300 psi (21 bar);
- European 97/23/EC Directive compliant for pressure equipment (PED);
- built in accordance with ASME code section X;
- D.M. n.174 dated 06/04/2004 compliant about materials suitable for contact with water for human consumption;
- each vessel is factory tested at 1,5 times max operating pressure;
- feed/concentrate connections 1" Victaulic, 0° or 180° oriented;
- permeate connections 1/2" BSPT F;
- straps and saddles included (n.2 pcs from 1 to 3 elements, n.3 pcs from 4 to 6 elements).

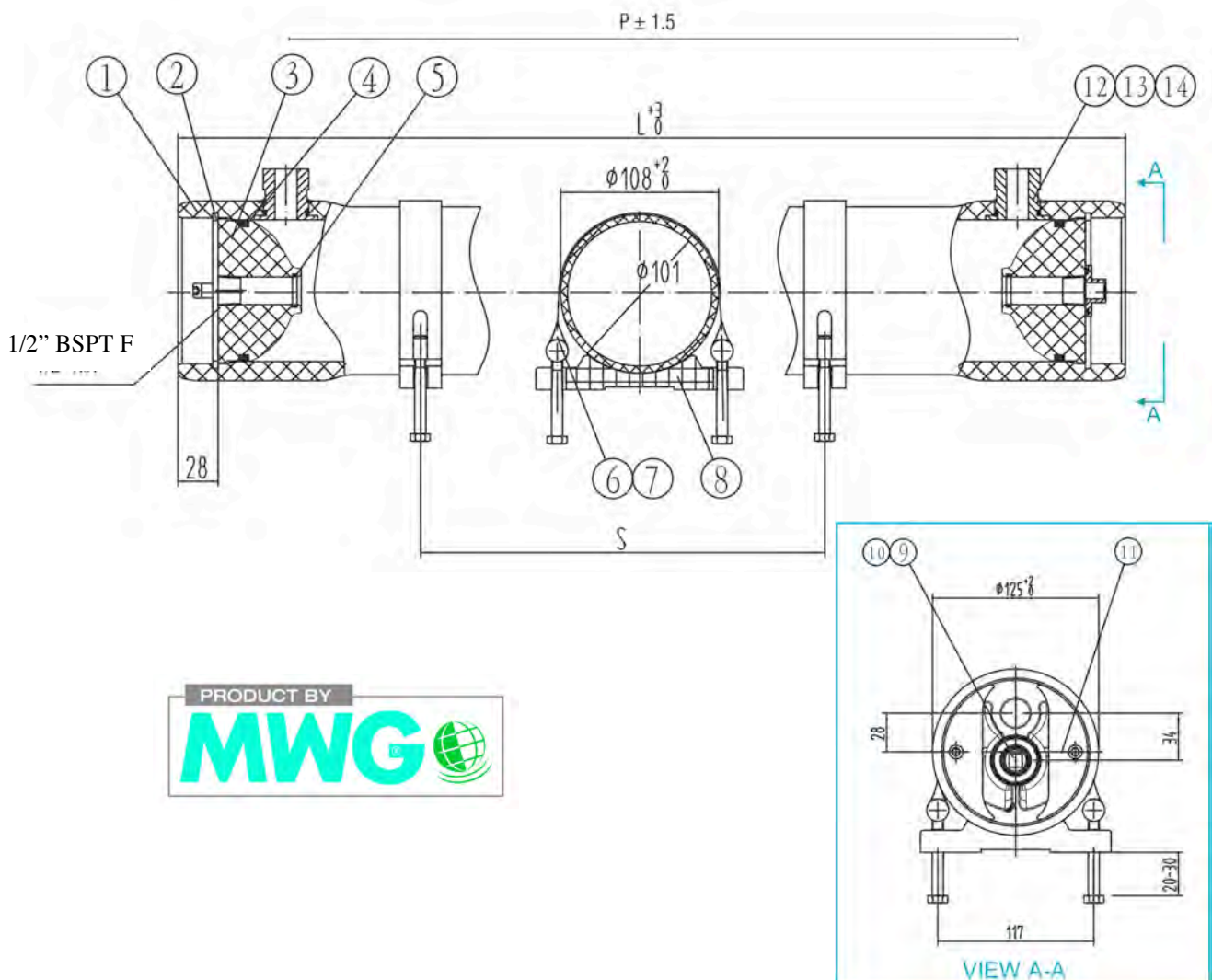

4" Membrane Vessels Side Port Series 300 S-4



REF.	MODEL	ELEMENTS	L (mm)	P (mm)	S (mm)	ORIENT.	
H410B1 (*)	300 S-4-1D5D-1	1 x 40"	1140	984	600	0°	
H410B2 (*)	300 S-4-1D5D-2	2 x 40"	2156	2000	1200	0°	
H410B3 (*)	300 S-4-1D5D-3	3 x 40"	3172	3016	2200	0°	
H410B4 (*)	300 S-4-1D5D-4	4 x 40"	4268	4112	1600x2	0°	
H410B5 (*)	300 S-4-1D5D-5	5 x 40"	5284	5128	2300x2	0°	
H410B6 (*)	300 S-4-1D5D-6	6 x 40"	6300	6144	2700x2	0°	
H412B1	300 S-4-1D7D-1	1 x 40"	1140	984	600	180°	
H412B2	300 S-4-1D7D-2	2 x 40"	2156	2000	1200	180°	
H412B3	300 S-4-1D7D-3	3 x 40"	3172	3016	2200	180°	
H412B4 (*)	300 S-4-1D7D-4	4 x 40"	4268	4112	1600x2	180°	
H412B5 (*)	300 S-4-1D7D-5	5 x 40"	5284	5128	2300x2	180°	
H412B6 (*)	300 S-4-1D7D-6	6 x 40"	6300	6144	2700x2	180°	

(*) not available in stock – Delivery 8-10 weeks.

SPARE PARTS						
ITEM	REF.	DESCRIPTION	QUANTITY	MATERIAL	REMARK	
1		Pressure Shell	1	Epoxy FRP	White	
2	H4R041	Seeger	4	AISI 304		
3 + 5	H4R405	End Plate	2	ABS		
4	H4R107	Head Seal	2	EPDM	90x5,3	
5	H2R101	Adapter Seal	2	EPDM	19x2,65	
6 + 7	H4R003	Strap	2-3	AISI 304 - Rubber		
7	H4R201	Strap Screw	4-6	AISI 304	M8x70	
8	H4R001	Saddle	2-3	Rubber		
9	H4R081	Plug	1	ABS		
10	H4R101	O-ring of Plug	1	EPDM	23,6x3,55	
11	H4R209	Seeger Screw	4	AISI 304	M6x14	
12	H4R301	Feed/Concentrate Port	2-4	AISI 316		
13	H4R103	O-Ring of Feed/Conc. Port	2-4	EPDM	28x2,65	
14	H4R505	Retaining Ring	2-4	AISI 304		

4" Membrane Vessels Side Port Series 600 S-4



- fiberglass reinforced plastic pressure vessels series 600 S-4, D.75" direct connection, white painted, UVA-ray proof material;
- max operating pressure 600 psi (41 bar);
- European 97/23/EC Directive compliant for pressure equipment (PED);
- built in accordance with ASME code section X;
- D.M. n.174 dated 06/04/2004 compliant about materials suitable for contact with water for human consumption;
- each vessel is factory tested at 1,5 times max operating pressure;
- feed/conc. connections 1" Victaulic, 0° or 180° oriented, in super duplex steel AISI 2507;
- permeate connections ½" BSPT M;
- straps and saddles included (n.2 pcs from 1 to 3 elements, n.3 pcs from 4 to 6 elements).

REF.	MODEL	ELEMENTS	L (mm)	P (mm)	S (mm)	ORIENT.	
H410D1 (*)	600 S-4-1D5D-1	1 x 40"	1364	1036	600	0°	
H410D2 (*)	600 S-4-1D5D-2	2 x 40"	2380	2052	1200	0°	
H410D3 (*)	600 S-4-1D5D-3	3 x 40"	3396	3068	2200	0°	
H410D4 (*)	600 S-4-1D5D-4	4 x 40"	4412	4084	1600x2	0°	
H410D5 (*)	600 S-4-1D5D-5	5 x 40"	5428	5100	2300x2	0°	
H410D6 (*)	600 S-4-1D5D-6	6 x 40"	6444	6116	2700x2	0°	
H412D1	600 S-4-1D7D-1	1 x 40"	1364	1036	600	180°	
H412D2	600 S-4-1D7D-2	2 x 40"	2380	2052	1200	180°	
H412D3	600 S-4-1D7D-3	3 x 40"	3396	3068	2200	180°	
H412D4 (*)	600 S-4-1D7D-4	4 x 40"	4412	4084	1600x2	180°	
H412D5 (*)	600 S-4-1D7D-5	5 x 40"	5428	5100	2300x2	180°	
H412D6 (*)	600 S-4-1D7D-6	6 x 40"	6444	6116	2700x2	180°	

(*) not available in stock – Delivery 8-10 weeks.

4" Membrane Vessels Side Port Series 600 S-4

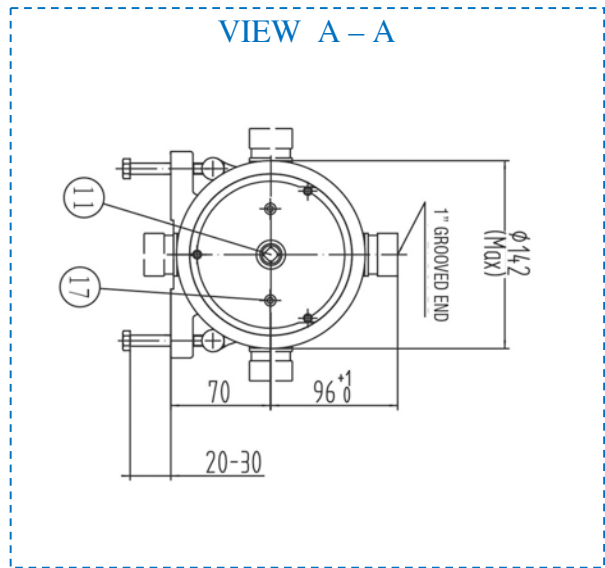
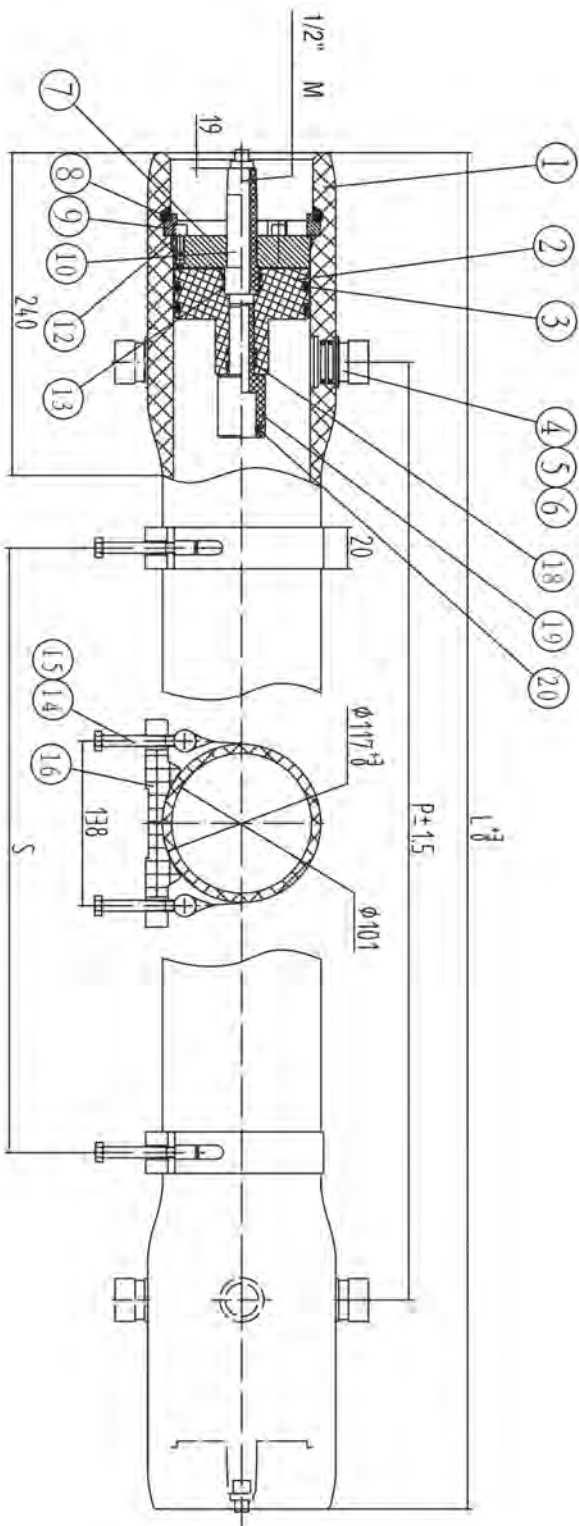

4" Membrane Vessels Side Port Series 1000 S-4



- fiberglass reinforced plastic pressure vessels series 1000 S-4, D.75" direct connection, white painted, UVA-ray proof material;
- max operating pressure 1000 psi (69 bar);
- European 97/23/EC Directive compliant for pressure equipment (PED);
- built in accordance with ASME code section X;
- D.M. n.174 dated 06/04/2004 compliant about materials suitable for contact with water for human consumption;
- each vessel is factory tested at 1,5 times max operating pressure;
- feed/conc. connections 1" Victaulic, 0° or 180° oriented, in super duplex steel AISI 2507;
- permeate connections ½" BSPT M;
- straps and saddles included (n.2 pcs from 1 to 3 elements, n.3 pcs from 4 to 6 elements).

REF.	MODEL	ELEMENTS	L (mm)	P (mm)	S (mm)	ORIENT.	
H410G1 (*)	1000 S-4-1D5D-1	1 x 40"	1364	1036	600	0°	
H410G2 (*)	1000 S-4-1D5D-2	2 x 40"	2380	2052	1200	0°	
H410G3 (*)	1000 S-4-1D5D-3	3 x 40"	3396	3068	2200	0°	
H410G4 (*)	1000 S-4-1D5D-4	4 x 40"	4412	4084	1600x2	0°	
H410G5 (*)	1000 S-4-1D5D-5	5 x 40"	5428	5100	2300x2	0°	
H410G6 (*)	1000 S-4-1D5D-6	6 x 40"	6444	6116	2700x2	0°	
H412G1	1000 S-4-1D7D-1	1 x 40"	1364	1036	600	180°	
H412G2	1000 S-4-1D7D-2	2 x 40"	2380	2052	1200	180°	
H412G3	1000 S-4-1D7D-3	3 x 40"	3396	3068	2200	180°	
H412G4 (*)	1000 S-4-1D7D-4	4 x 40"	4412	4084	1600x2	180°	
H412G5 (*)	1000 S-4-1D7D-5	5 x 40"	5428	5100	2300x2	180°	
H412G6 (*)	1000 S-4-1D7D-6	6 x 40"	6444	6116	2700x2	180°	

(*) not available in stock – Delivery 8-10 weeks.

4" Membrane Vessels Side Port Series 1000 S-4

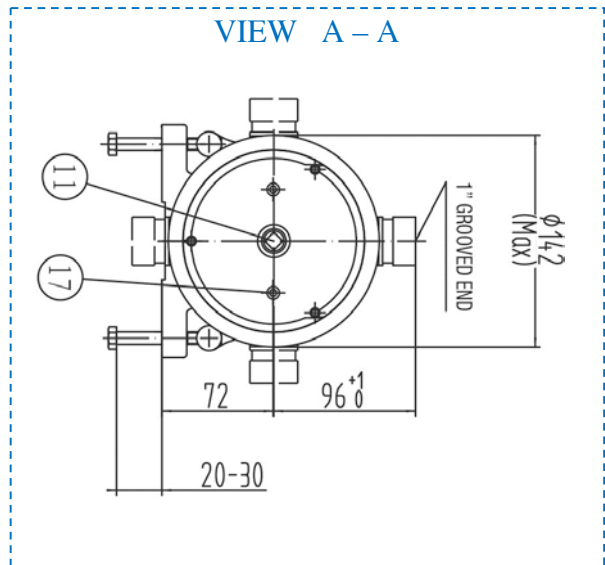
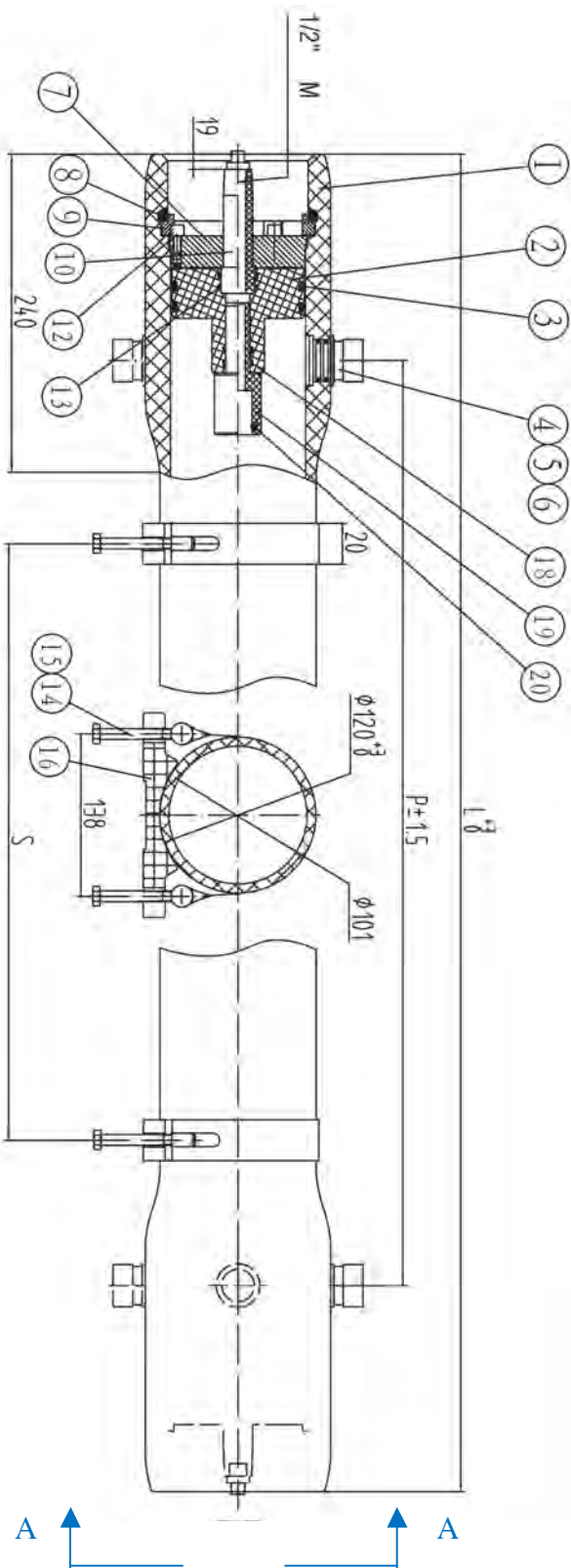

4" Membrane Vessels Side Port Series 1200 S-4



- fiberglass reinforced plastic pressure vessels series 1200 S-4, D.75" direct connection, white painted, UVA-ray proof material;
- max operating pressure 1200 psi (83 bar);
- European 97/23/EC Directive compliant for pressure equipment (PED);
- built in accordance with ASME code section X;
- D.M. n.174 dated 06/04/2004 compliant about materials suitable for contact with water for human consumption;
- each vessel is factory tested at 1,5 times max operating pressure;
- feed/conc. connections 1" Victaulic, 0° or 180° oriented, in super duplex steel AISI 2507;
- permeate connections ½" BSPT M;
- straps and saddles included (n.2 pcs from 1 to 3 elements, n.3 pcs from 4 to 6 elements).

REF.	MODEL	ELEMENTS	L (mm)	P (mm)	S (mm)	ORIENT.	
H410H1 (*)	1200 S-4-1D5D-1	1 x 40"	1364	1036	600	0°	
H410H2 (*)	1200 S-4-1D5D-2	2 x 40"	2380	2052	1200	0°	
H410H3 (*)	1200 S-4-1D5D-3	3 x 40"	3396	3068	2200	0°	
H410H4 (*)	1200 S-4-1D5D-4	4 x 40"	4412	4084	1600x2	0°	
H410H5 (*)	1200 S-4-1D5D-5	5 x 40"	5428	5100	2300x2	0°	
H410H6 (*)	1200 S-4-1D5D-6	6 x 40"	6444	6116	2700x2	0°	
H412H1	1200 S-4-1D7D-1	1 x 40"	1364	1036	600	180°	
H412H2	1200 S-4-1D7D-2	2 x 40"	2380	2052	1200	180°	
H412H3	1200 S-4-1D7D-3	3 x 40"	3396	3068	2200	180°	
H412H4 (*)	1200 S-4-1D7D-4	4 x 40"	4412	4084	1600x2	180°	
H412H5 (*)	1200 S-4-1D7D-5	5 x 40"	5428	5100	2300x2	180°	
H412H6 (*)	1200 S-4-1D7D-6	6 x 40"	6444	6116	2700x2	180°	

(*) not available in stock – Delivery 8-10 weeks.

4" Membrane Vessels Side Port Series 1200 S-4

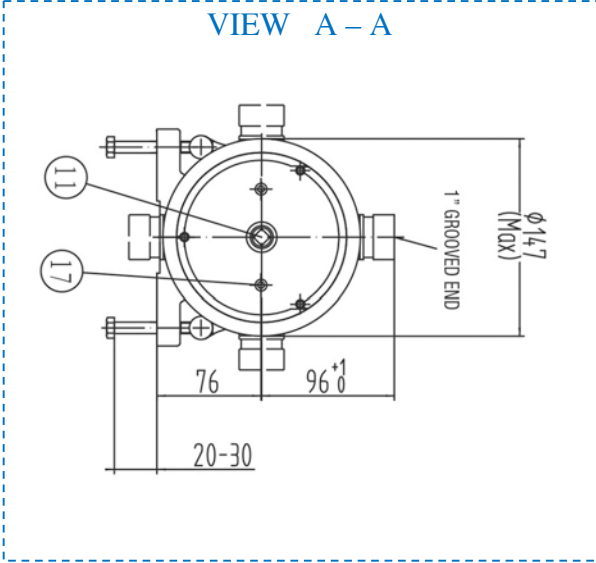
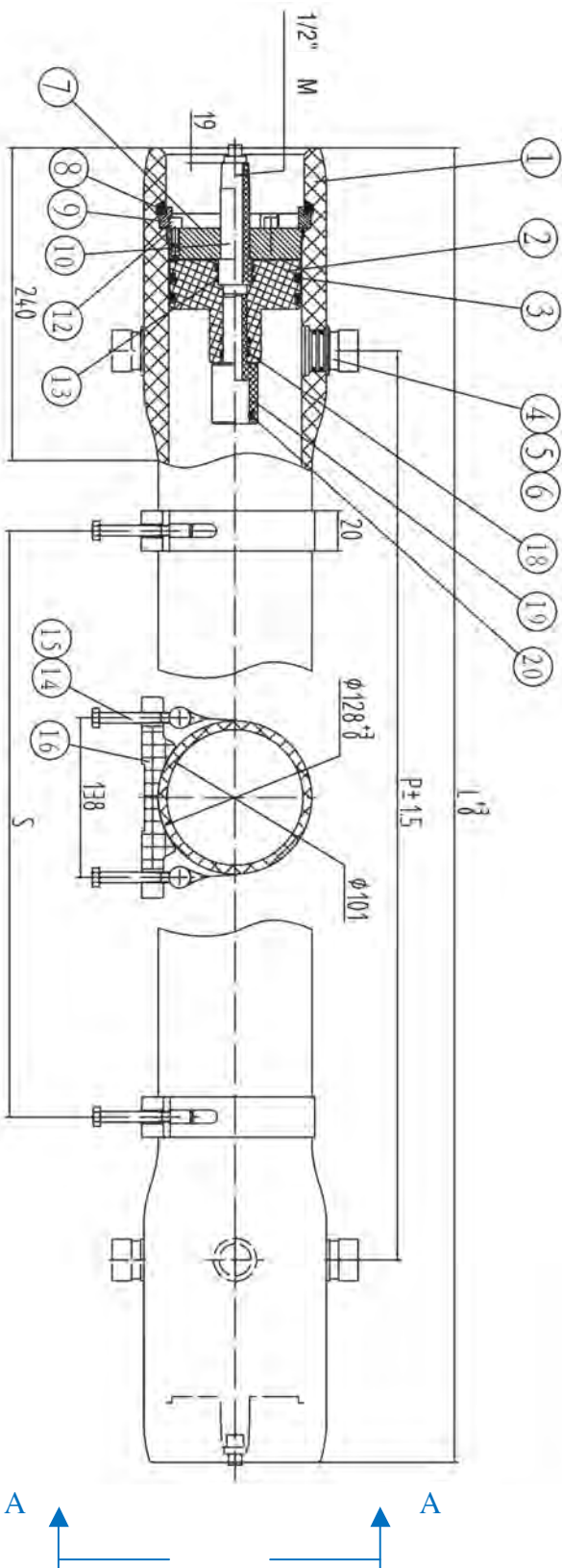

4" Side Port 600-1000-1200 Psi Vessels Spare Parts

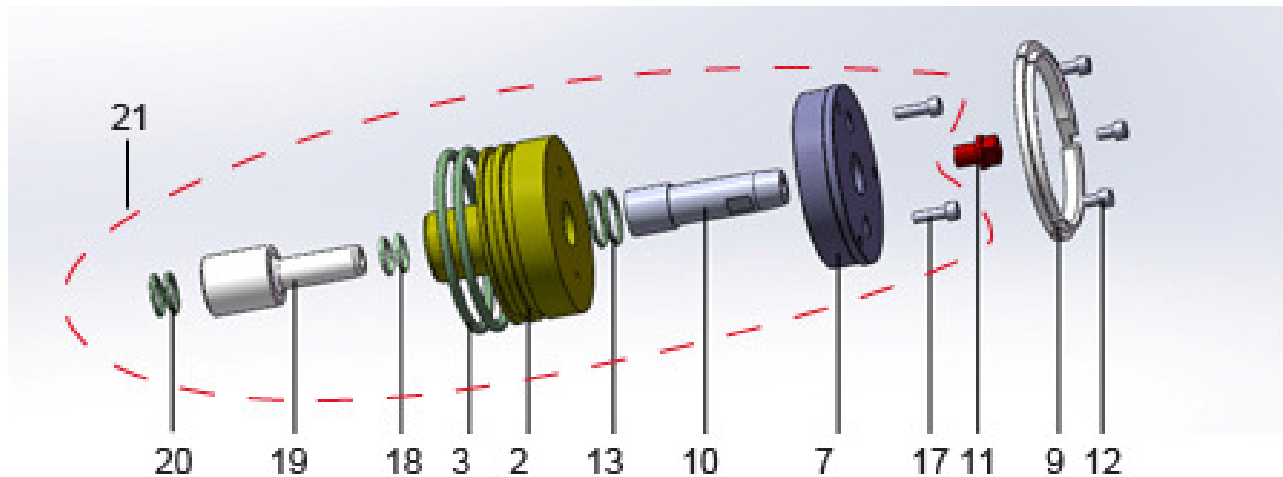

ITEM	REF.	DESCRIPTION	Q.TY	MATERIAL	NOTE	
3	H4R107	Head Seal	4	EPDM	90x5,3	
9	H4R045	Locking Kit (n.3 Segments)	2	AISI 316		
11	H4R083	Plug	1	ABS		
12	H4R205	Securing Screw	6	AISI 304	M6x20	
13	H4R111	O-ring of Permeate Port	4	EPDM	25x2,65	
NOT SHOWN	H4R005	Strap	2-3	AISI 304 - Rubber		
NOT SHOWN	H4R201	Strap Screw	4-6	AISI 304	M8x70	
NOT SHOWN	H4R001	Saddle	2-3	Rubber		
18	H4R113	O-ring of Sealing Plate	4	EPDM	17x2,65	
20	H2R101	Adapter Seal	4	EPDM	19x2,65	
21	H4R717	Head Assembly side port	2			

8" Membrane Vessels End Port Series 300 E-8



- fiberglass reinforced plastic pressure vessels series 300 E-8, white painted, UVA-ray proof material;
- max operating pressure 300 psi (21 bar);
- European 97/23/EC Directive compliant for pressure equipment (PED);
- built in accordance with ASME code section X;
- D.M. n.174 dated 06/04/2004 compliant about materials suitable for contact with water for human consumption;
- each vessel is factory tested at 1,5 times max operating pressure;
- feed/concentrate connections 1 ½" Victaulic;
- permeate connections 1" BSPT F;
- straps and saddles included (n.2 pcs from 1 to 3 elements, n.3 pcs from 4 to 7 elements);
- 1,125" membrane adapters included.

REF.	MODEL	ELEMENTS	L (mm)	S (mm)	
H8E5B1	300 E – 8040 – 1	1 x 40"	1498	700	
H8E5B2	300 E – 8040 – 2	2 x 40"	2514	1460	
H8E5B3	300 E – 8040 – 3	3 x 40"	3530	2080	
H8E5B4	300 E – 8040 – 4	4 x 40"	4546	1600x2	
H8E5B5	300 E – 8040 – 5	5 x 40"	5562	2000x2	
H8E5B6	300 E – 8040 – 6	6 x 40"	6578	2360x2	
H8E5B7 (*)	300 E – 8040 – 7	7 x 40"	7594	2860x2	

(*) not available in stock – Delivery 8-10 weeks.

8" Membrane Vessels End Port Series 300 E-8

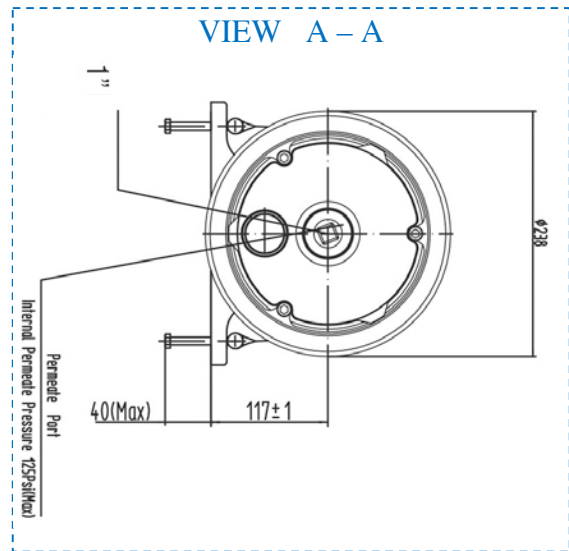
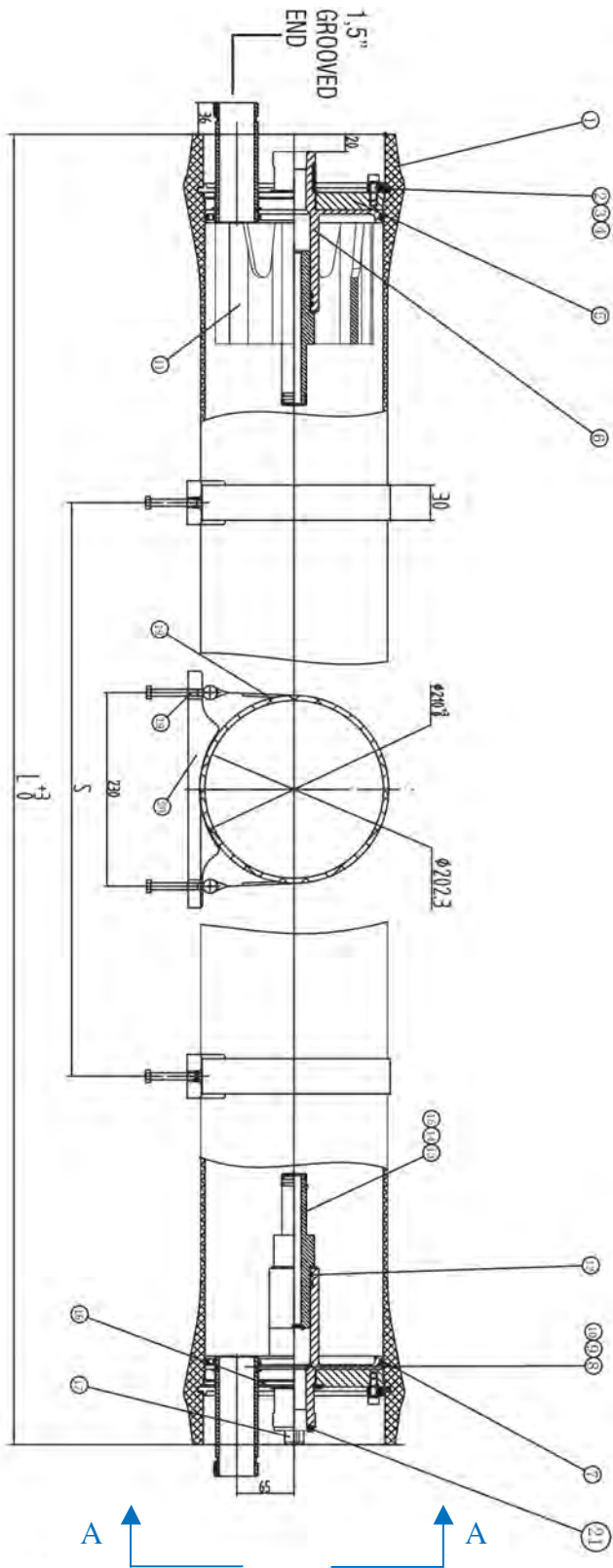

8" Membrane Vessels End Port Series 450 E-8



- fiberglass reinforced plastic pressure vessels series 450 E-8, white painted, UVA-ray proof material;
- max operating pressure 450 psi (31 bar);
- European 97/23/EC Directive compliant for pressure equipment (PED);
- built in accordance with ASME code section X;
- D.M. n.174 dated 06/04/2004 compliant about materials suitable for contact with water for human consumption;
- each vessel is factory tested at 1,5 times max operating pressure;
- feed/concentrate connections 1 ½" Victaulic;
- permeate connections 1" BSPT F;
- straps and saddles included (n.2 pcs from 1 to 3 elements, n.3 pcs from 4 to 7 elements);
- 1,125" membrane adapters included.

REF.	MODEL	ELEMENTS	L (mm)	S (mm)	
H8E5C1	450 E – 8040 – 1	1 x 40"	1498	700	
H8E5C2	450 E – 8040 – 2	2 x 40"	2514	1460	
H8E5C3	450 E – 8040 – 3	3 x 40"	3530	2080	
H8E5C4 (*)	450 E – 8040 – 4	4 x 40"	4546	1600x2	
H8E5C5 (*)	450 E – 8040 – 5	5 x 40"	5562	2000x2	
H8E5C6 (*)	450 E – 8040 – 6	6 x 40"	6578	2360x2	
H8E5C7 (*)	450 E – 8040 – 7	7 x 40"	7594	2860x2	

(*) not available in stock – Delivery 8-10 weeks.

8" Membrane Vessels End Port Series 450 E-8

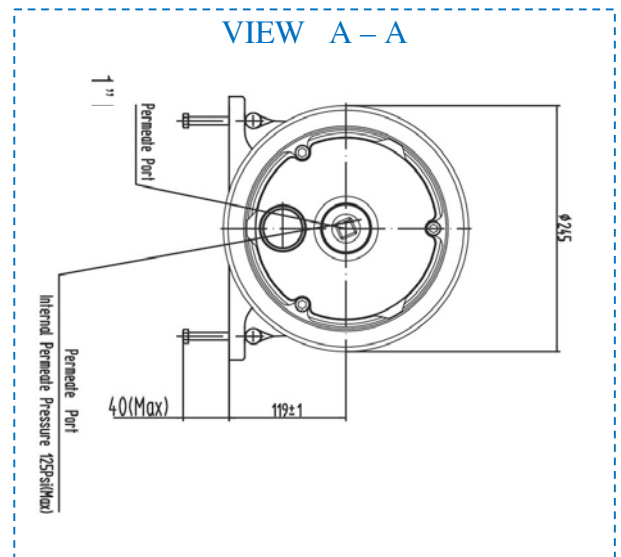
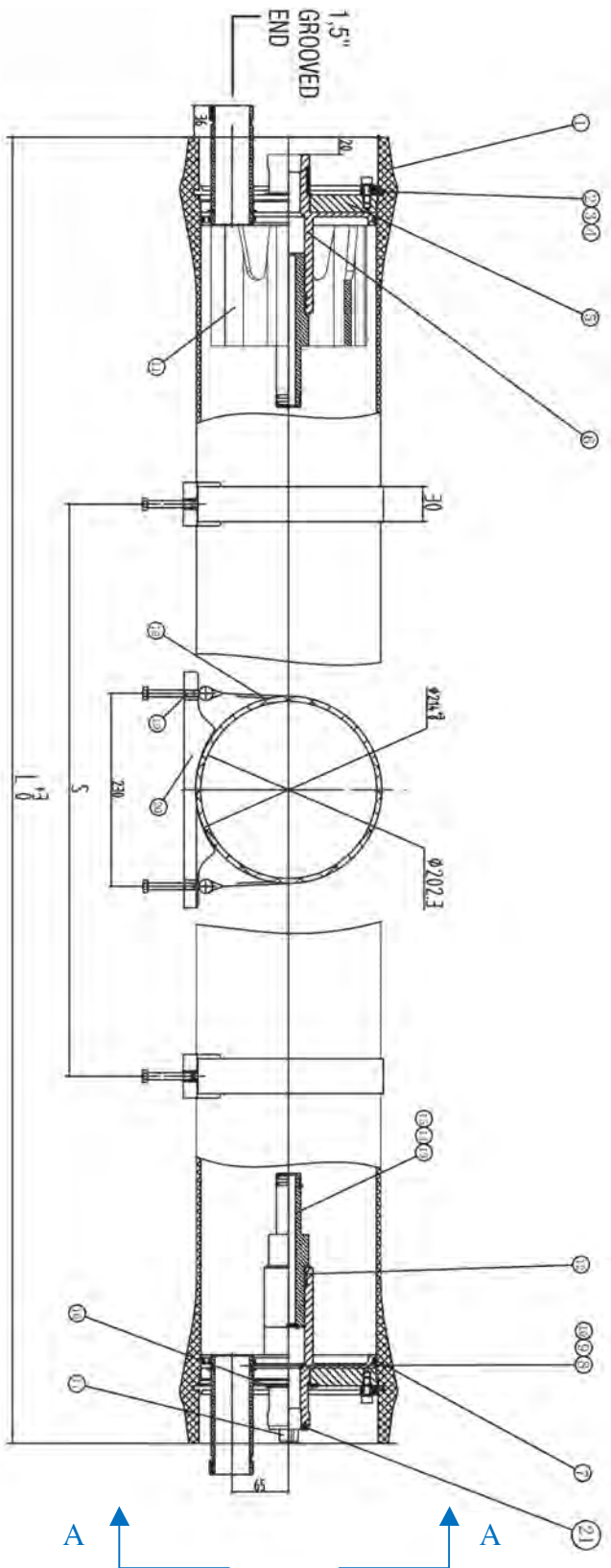

8" Membrane Vessels End Port Series 600 E-8



- fiberglass reinforced plastic pressure vessels series 600 E-8, white painted, UVA-ray proof material;
- max operating pressure 600 psi (41 bar);
- European 97/23/EC Directive compliant for pressure equipment (PED);
- built in accordance with ASME code section X;
- D.M. n.174 dated 06/04/2004 compliant about materials suitable for contact with water for human consumption;
- each vessel is factory tested at 1,5 times max operating pressure;
- feed/concentrate connections 1 ½" Victaulic in super duplex steel AISI 2507;
- permeate connections 1" BSPT F;
- straps and saddles included (n.2 pcs from 1 to 3 elements, n.3 pcs from 4 to 7 elements);
- 1,125" membrane adapters included.

REF.	MODEL	ELEMENTS	L (mm)	S (mm)	
H8E5D1	600 E – 8040 – 1	1 x 40"	1514	700	
H8E5D2	600 E – 8040 – 2	2 x 40"	2530	1460	
H8E5D3 (*)	600 E – 8040 – 3	3 x 40"	3546	2080	
H8E5D4 (*)	600 E – 8040 – 4	4 x 40"	4562	1600x2	
H8E5D5 (*)	600 E – 8040 – 5	5 x 40"	5578	2000x2	
H8E5D6 (*)	600 E – 8040 – 6	6 x 40"	6594	2360x2	
H8E5D7 (*)	600 E – 8040 – 7	7 x 40"	7610	2860x2	

(*) not available in stock – Delivery 8-10 weeks.

8" Membrane Vessels End Port Series 600 E-8

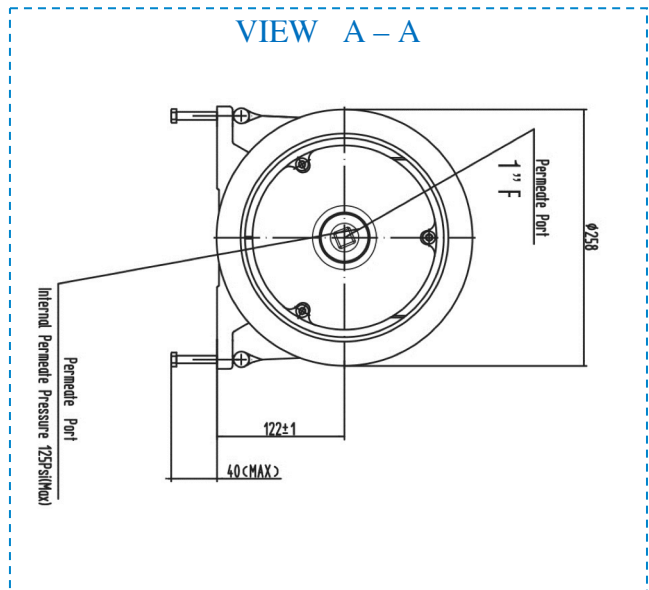
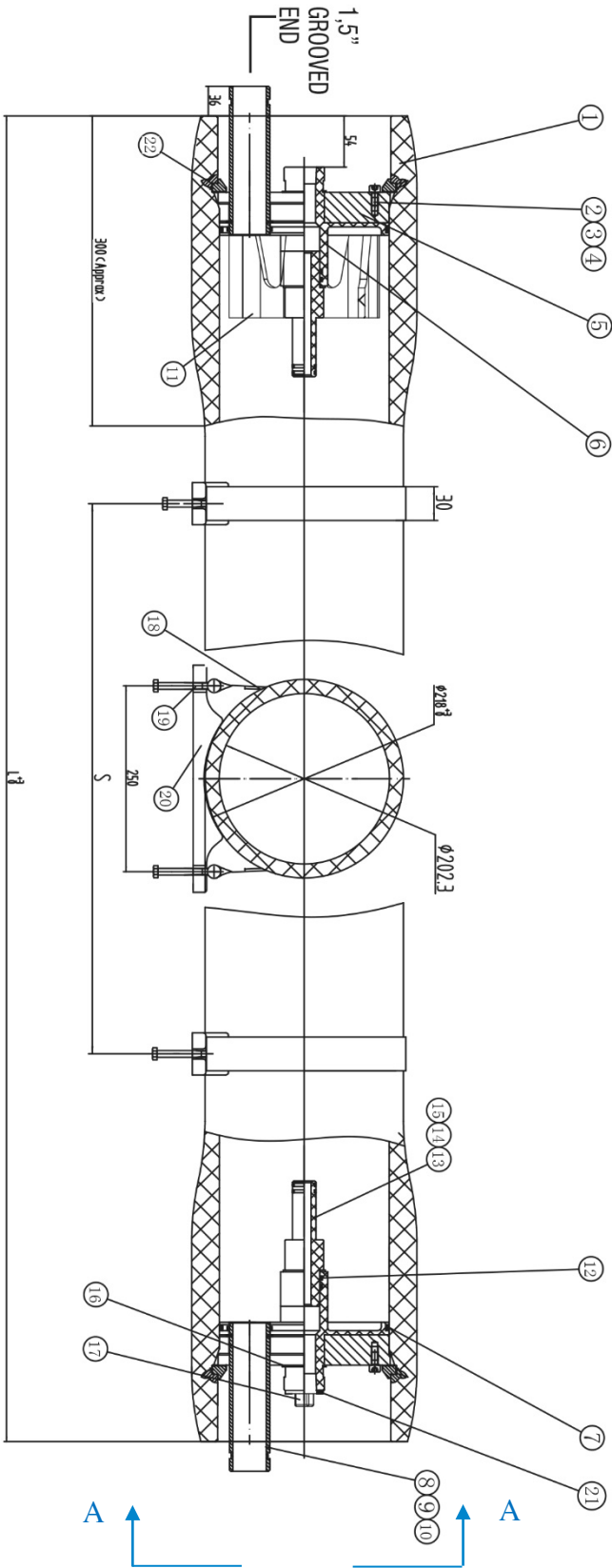

8" Membrane Vessels End Port Series 1000 E-8



- fiberglass reinforced plastic pressure vessels series 1000 E-8, white painted, UVA-ray proof material;
- max operating pressure 1000 psi (69 bar);
- European 97/23/EC Directive compliant for pressure equipment (PED);
- built in accordance with ASME code section X;
- D.M. n.174 dated 06/04/2004 compliant about materials suitable for contact with water for human consumption;
- each vessel is factory tested at 1,5 times max operating pressure;
- feed/concentrate connections 1 ½" Victaulic in super duplex steel AISI 2507;
- permeate connections 1" BSPT F;
- straps and saddles included (n.2 pcs from 1 to 3 elements, n.3 pcs from 4 to 7 elements);
- 1,125" membrane adapters included.

REF.	MODEL	ELEMENTS	L (mm)	S (mm)	
H8E5G1	1000 E – 8040 – 1	1 x 40"	1514	700	
H8E5G2	1000 E – 8040 – 2	2 x 40"	2530	1460	
H8E5G3	1000 E – 8040 – 3	3 x 40"	3546	2080	
H8E5G4 (*)	1000 E – 8040 – 4	4 x 40"	4562	1600x2	
H8E5G5 (*)	1000 E – 8040 – 5	5 x 40"	5578	2000x2	
H8E5G6 (*)	1000 E – 8040 – 6	6 x 40"	6594	2360x2	
H8E5G7 (*)	1000 E – 8040 – 7	7 x 40"	7610	2860x2	

(*) not available in stock – Delivery 8-10 weeks.

8" Membrane Vessels End Port Series 1000 E-8

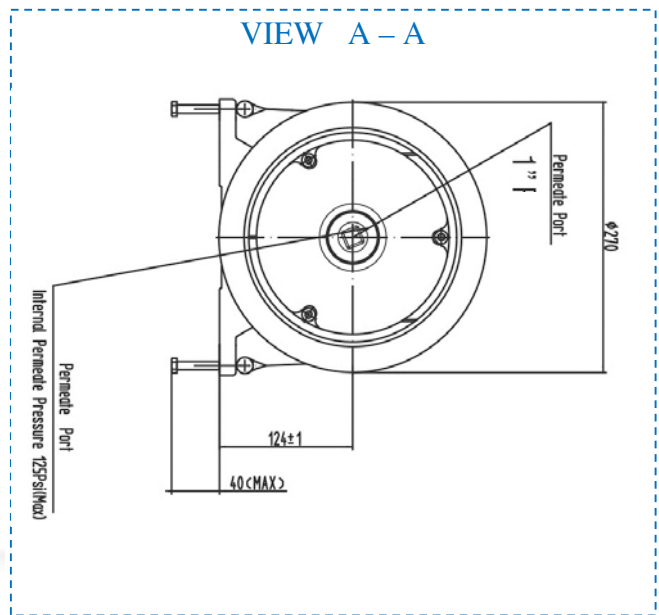
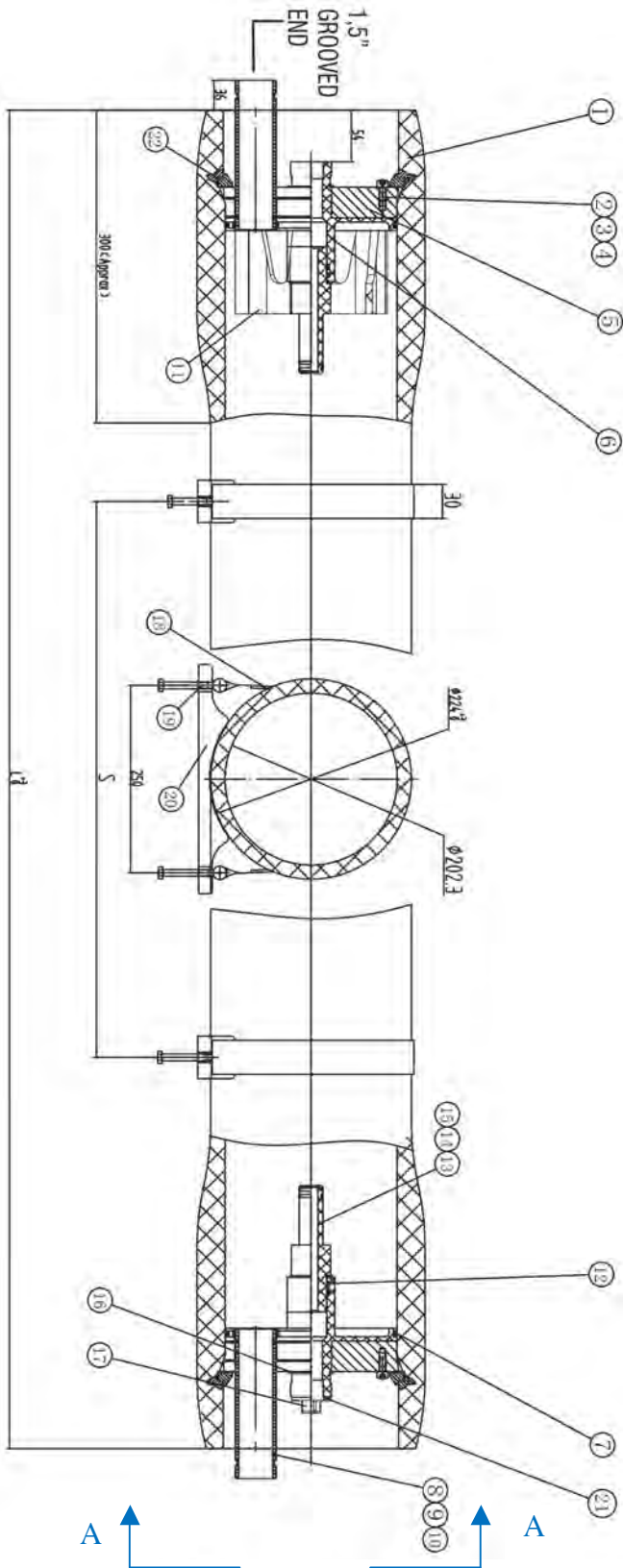

8" Membrane Vessels End Port Series 1200 E-8



- fiberglass reinforced plastic pressure vessels series 1000 E-8, white painted, UVA-ray proof material;
- max operating pressure 1200 psi (83 bar);
- European 97/23/EC Directive compliant for pressure equipment (PED);
- built in accordance with ASME code section X;
- D.M. n.174 dated 06/04/2004 compliant about materials suitable for contact with water for human consumption;
- each vessel is factory tested at 1,5 times max operating pressure;
- feed/concentrate connections 1 ½" Victaulic in super duplex steel AISI 2507;
- permeate connections 1" BSPT F;
- straps and saddles included (n.2 pcs from 1 to 3 elements, n.3 pcs from 4 to 7 elements);
- 1,125" membrane adapters included.

REF.	MODEL	ELEMENTS	L (mm)	S (mm)	
H8E5H1	1200 E – 8040 – 1	1 x 40"	1514	700	
H8E5H2	1200 E – 8040 – 2	2 x 40"	2530	1460	
H8E5H3	1200 E – 8040 – 3	3 x 40"	3546	2080	
H8E5H4 (*)	1200 E – 8040 – 4	4 x 40"	4562	1600x2	
H8E5H5 (*)	1200 E – 8040 – 5	5 x 40"	5578	2000x2	
H8E5H6 (*)	1200 E – 8040 – 6	6 x 40"	6594	2360x2	
H8E5H7 (*)	1200 E – 8040 – 7	7 x 40"	7610	2860x2	

(*) not available in stock – Delivery 8-10 weeks.

8" Membrane Vessels End Port Series 1200 E-8

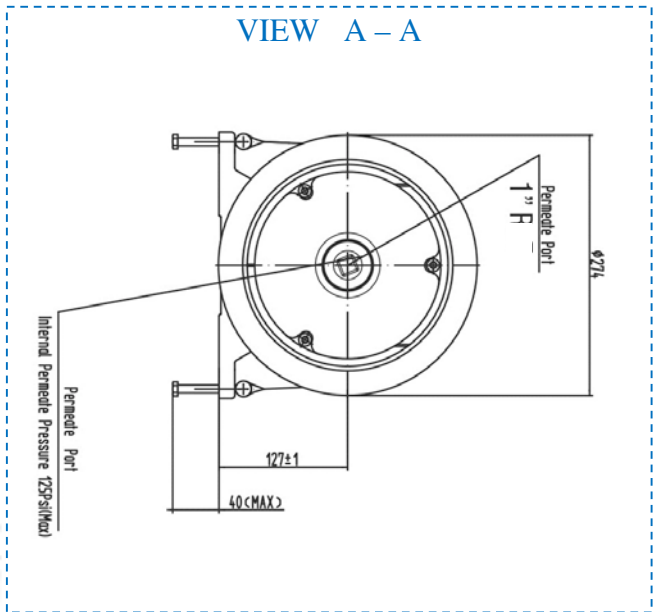
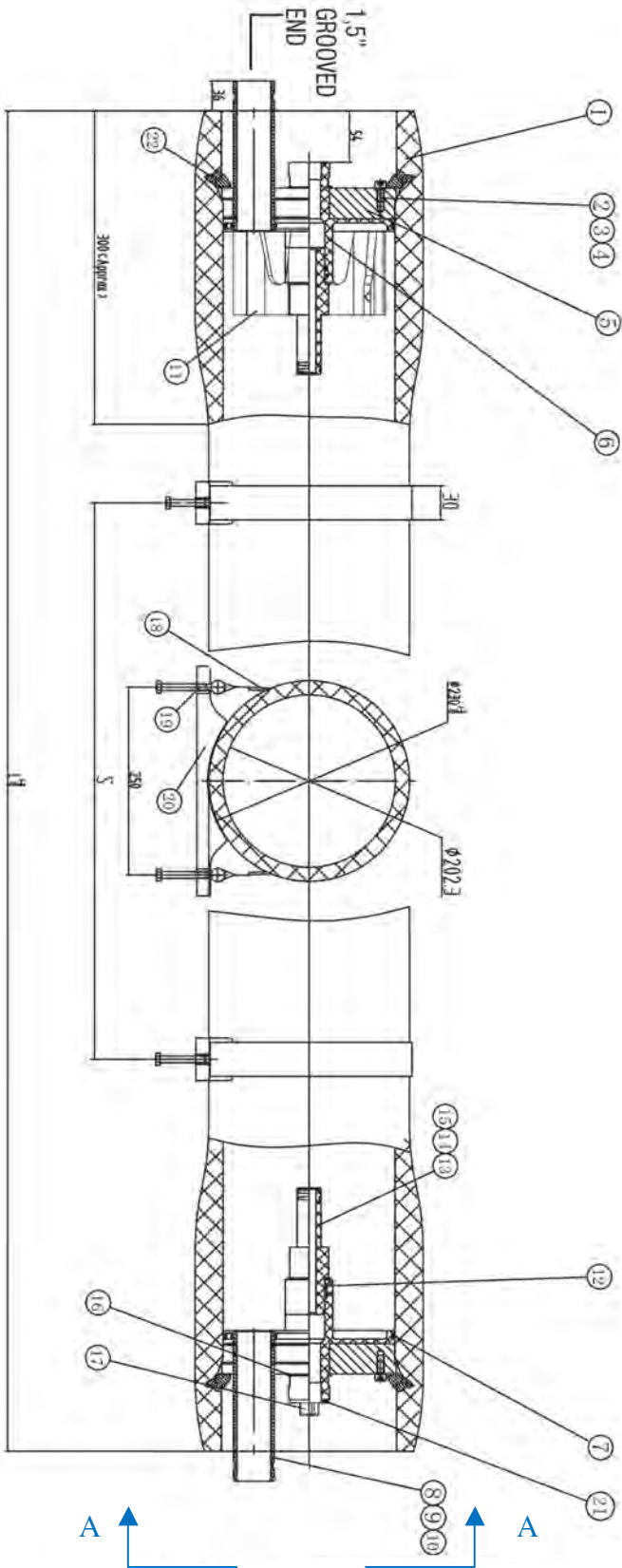

8" End Port 300-450 Psi Vessels Spare Parts

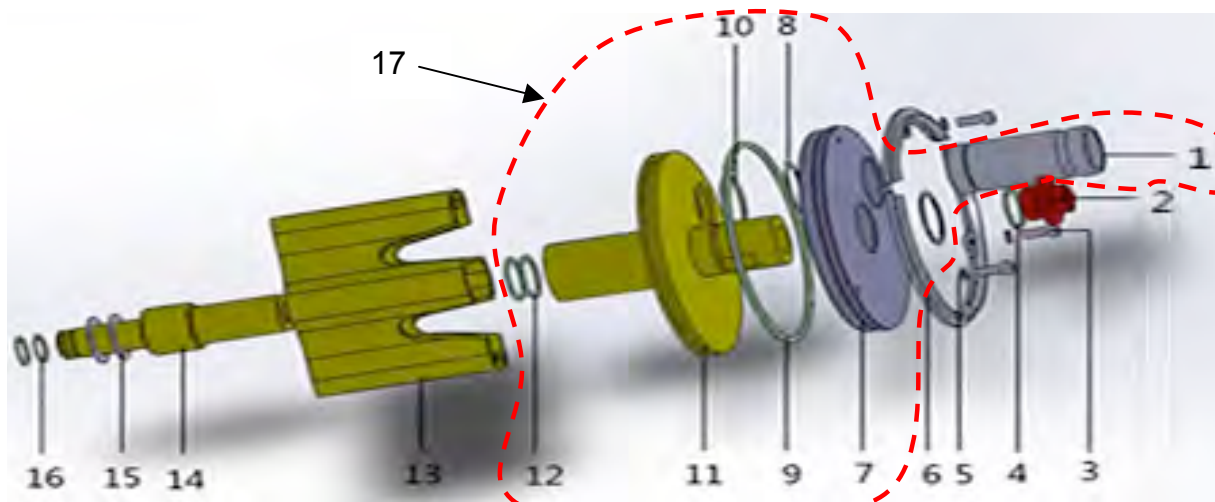

ITEM	REF.	DESCRIPTION	MATERIAL	
1		FEED CONCENTRATE PORT 1,5" VICTAULIC	AISI 316	
2	H8R081	PLUG	ABS	
3	H8R203	LOCKING SEGMENT SCREW	AISI 304	
4	H8R111	PWT SEAL	EPDM	
5	H8R031	SPRING PAD	AISI 304	
6	H8R041	LOCKING SEGMENT	AISI 304	
7		BEARING PLATE	ALUMINUM	
8		RETAINING RING	AISI 304	
9	H8R107	HEAD SEAL	EPDM	
10	H8R109	FEED CONCENTRATE PORT SEAL	EPDM	
11		SEALING PLATE (PERMEATE PORT)	ABS	
12	H8R111	PWT SEAL	EPDM	
13	H8R061	THRUST CONE	ABS	
14 + 16	H8R601	1,125" ADAPTER	ABS	
15	H8R651	1,125" ADAPTER PAD	ABS	
16	H8R113	1,125" ADAPTER O-RING	EPDM	
17	H8R701	HEAD ASSEMBLY END PORT 300 PSI		
	H8R703	HEAD ASSEMBLY END PORT 450 PSI		
NOT SHOWN	H8R001	SADDLE	RUBBER	
NOT SHOWN	H8R005	STRAP (L = 520 mm)	AISI 304 - RUBBER	

8" End Port 600-1000-1200 Psi Vessels Spare Parts

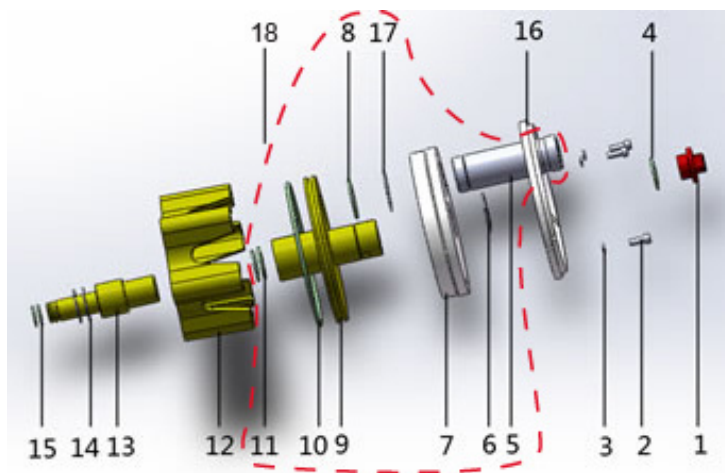

ITEM	REF.	DESCRIPTION	MATERIAL	
1	H8R081	PLUG	ABS	
2	H8R203	LOCKING SEGMENT SCREW	AISI 304	
3	H8R031	SPRING PAD	AISI 304	
4	H8R111	PWT SEAL	EPDM	
5		FEED CONC. PORT 1,5" VICTAULIC	SUPER DUPLEX AISI 2507	
8	H8R109	FEED CONCENTRATE PORT SEAL	EPDM	
9		SEALING PLATE (PERMEATE PORT)	ABS	
10	H8R107	HEAD SEAL	EPDM	
11	H8R111	PWT SEAL	EPDM	
12	H8R063	THRUST CONE	ABS	
13 + 15	H8R603	1,125" ADAPTER	ABS	
	H8R613	1,5" ADAPTER (OPTIONAL)	ABS	
14	H8R651	1,125" ADAPTER PAD	ABS	
	H8R653	1,5" ADAPTER PAD (OPTIONAL)	ABS	
15	H8R113	1,125" ADAPTER O-RING	EPDM	
	H8R115	1,5" ADAPTER O-RING (OPTIONAL)	EPDM	
16	H8R045	LOCKING KIT (N.3 SEGMENTS)	AISI 304	
18	H8R705	HEAD ASSEMBLY END PORT 600 PSI		
	H8R707	HEAD ASSEMBLY END PORT 1000 PSI		
	H8R709	HEAD ASSEMBLY END PORT 1200 PSI		
NOT SHOWN	H8R001	SADDLE	RUBBER	
NOT SHOWN	H8R009	STRAP (L = 580 mm)	AISI 304 - RUBBER	

8" Side Port Vessels Feed/Concentrate Port Options

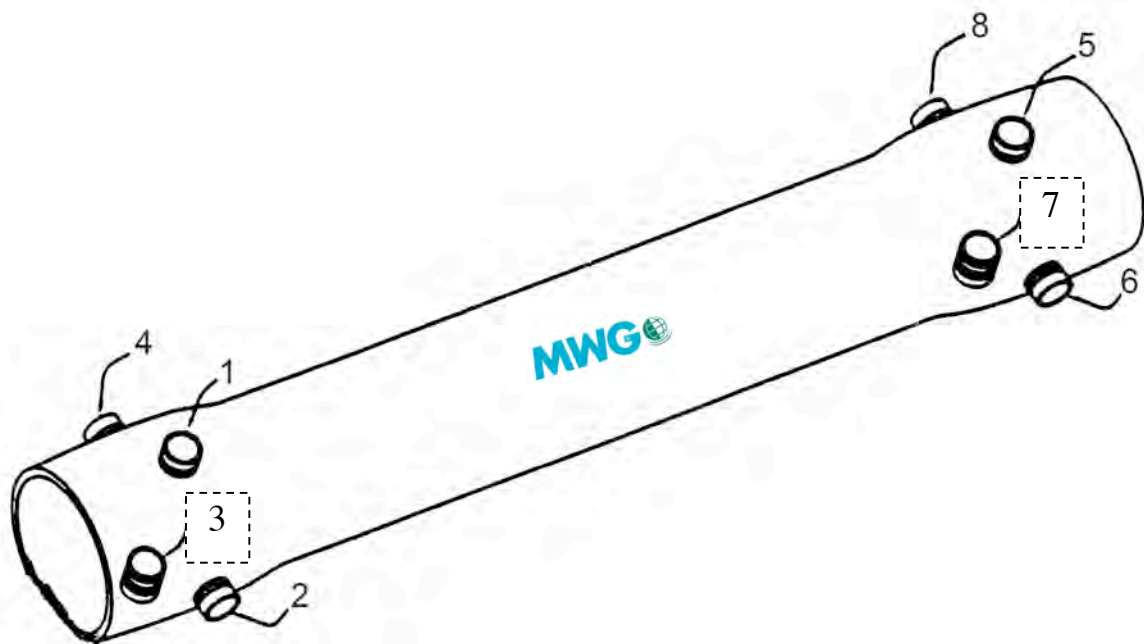

Each vessel 8" side port can have maximum 3 ports per each end, located in 4 different positions 90° among them. The drawing shows the numbers of different positions.

Each port can have three different dimensions:

- D = 1 ½" (standard connection)
- E = 2"
- F = 2 ½"
- G = 3"

Note: a 2 ½" port is not allowed at 90° from any other.

To determine the required configuration, identify the ports starting from N°1 with relevant dimension, complete this side and identify the opposite end.

Example: vessel with ports 1 & 5 connection 1 ½", ports 2 & 6 connection 2".

The configuration is: 1D 5D 2E 6E

8" Side Port Vessels Feed/Concentrate Port Options



Options for MWG 8" side port vessels

Vessel 8"		Add one extra port			
		1,5"	2"	2,5"	3"
PRESSURE (psi)	MATERIAL				
300	AISI 316				
450	AISI 316				
600	Super Duplex 2507				
1000	Super Duplex 2507				
1200	Super Duplex 2507				

Vessel 8"		UPGRADE from 1,5" port to ...		
		2"	2,5"	3"
PRESSURE (psi)	MATERIAL			
300	AISI 316			
450	AISI 316			
600	Super Duplex 2507			
1000	Super Duplex 2507			
1200	Super Duplex 2507			

8" Membrane Vessels Side Port Series 300 S-8



- fiberglass reinforced plastic pressure vessels series 300 S-8, white painted, UVA-ray proof material;
- max operating pressure 300 psi (21 bar);
- European 97/23/EC Directive compliant for pressure equipment (PED);
- built in accordance with ASME code section X;
- D.M. n.174 dated 06/04/2004 compliant about materials suitable for contact with water for human consumption;
- each vessel is factory tested at 1,5 times max operating pressure;
- feed/concentrate connections 1 ½" Victaulic (optional 2", 2 ½" or 3");
- permeate connections 1" BSPT F;
- straps and saddles included (n.2 pcs from 1 to 3 elements, n.3 pcs from 4 to 7 elements);
- 1,125" membrane adapters included;
- version from 2 to 7 ports (see list of options).

REF. ORIENT. 0°	REF. ORIENT. 180°	MODEL	ELEMENTS	L (mm)	P (mm)	S (mm)	
H815B1 (*)	H817B1 (*)	300S-8-1	1 x 40"	1494	1194	700	
H815B2 (*)	H817B2 (*)	300S-8-2	2 x 40"	2510	2210	1460	
H815B3 (*)	H817B3 (*)	300S-8-3	3 x 40"	3526	3226	2080	
H815B4 (*)	H817B4 (*)	300S-8-4	4 x 40"	4542	4242	1600x2	
H815B5 (*)	H817B5 (*)	300S-8-5	5 x 40"	5558	5258	2000x2	
H815B6 (*)	H817B6 (*)	300S-8-6	6 x 40"	6574	6274	2360x2	
H815B7 (*)	H817B7 (*)	300S-8-7	7 x 40"	7590	7290	2860x2	

(*) not available in stock – Delivery 8-10 weeks.

8" Membrane Vessels Side Port Series 300 S-8

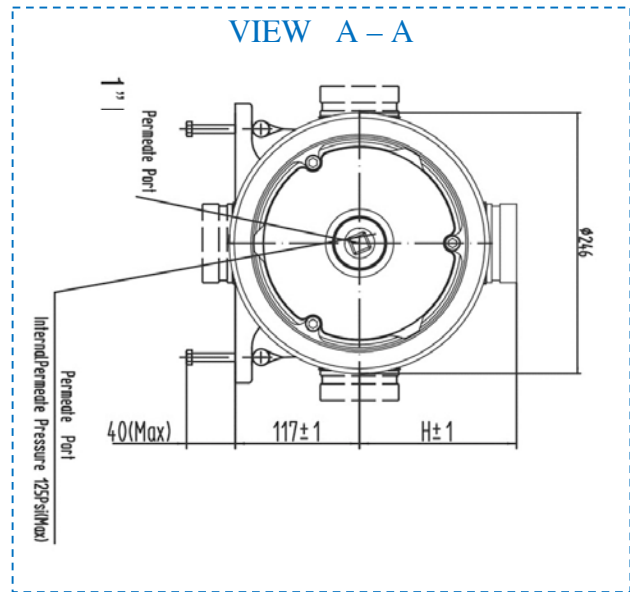
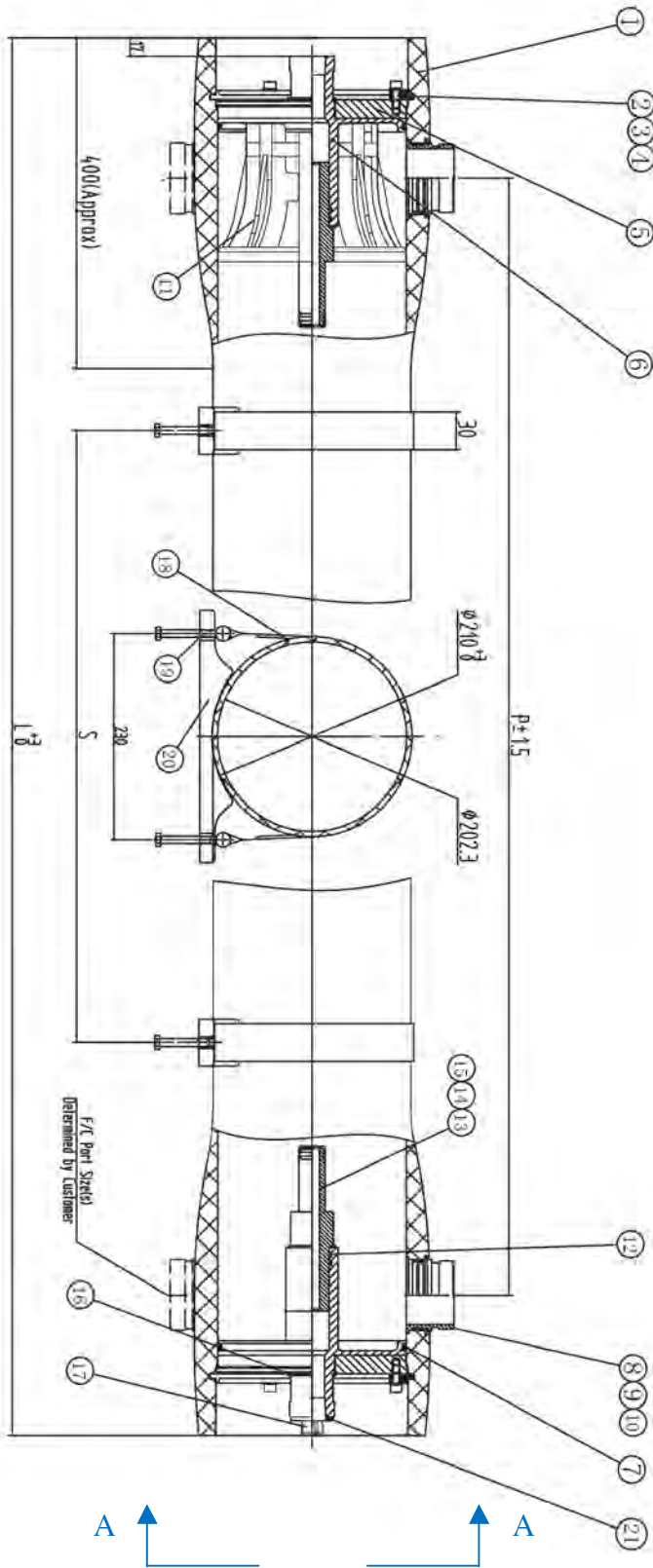

8" Membrane Vessels Side Port Series 450 S-8



- fiberglass reinforced plastic pressure vessels series 450 S-8, white painted, UVA-ray proof material;
- max operating pressure 450 psi (31 bar);
- European 97/23/EC Directive compliant for pressure equipment (PED);
- built in accordance with ASME code section X;
- D.M. n.174 dated 06/04/2004 compliant about materials suitable for contact with water for human consumption;
- each vessel is factory tested at 1,5 times max operating pressure;
- feed/concentrate connections 1 ½" Victaulic (optional 2", 2 ½" or 3");
- permeate connections 1" BSPT F;
- straps and saddles included (n.2 pcs from 1 to 3 elements, n.3 pcs from 4 to 7 elements);
- 1,125" membrane adapters included;
- version from 2 to 7 ports (see list of options).

REF. ORIENT. 0°	REF. ORIENT. 180°	MODEL	ELEMENTS	L (mm)	P (mm)	S (mm)	
H815C1 (*)	H817C1 (*)	450S-8-1	1 x 40"	1498	1194	700	
H815C2 (*)	H817C2 (*)	450S-8-2	2 x 40"	2514	2210	1460	
H815C3 (*)	H817C3 (*)	450S-8-3	3 x 40"	3530	3226	2080	
H815C4 (*)	H817C4 (*)	450S-8-4	4 x 40"	4546	4242	1600x2	
H815C5 (*)	H817C5 (*)	450S-8-5	5 x 40"	5562	5258	2000x2	
H815C6 (*)	H817C6 (*)	450S-8-6	6 x 40"	6578	6274	2360x2	
H815C7 (*)	H817C7 (*)	450S-8-7	7 x 40"	7594	7290	2860x2	

(*) not available in stock – Delivery 8-10 weeks.

8" Membrane Vessels Side Port Series 450 S-8

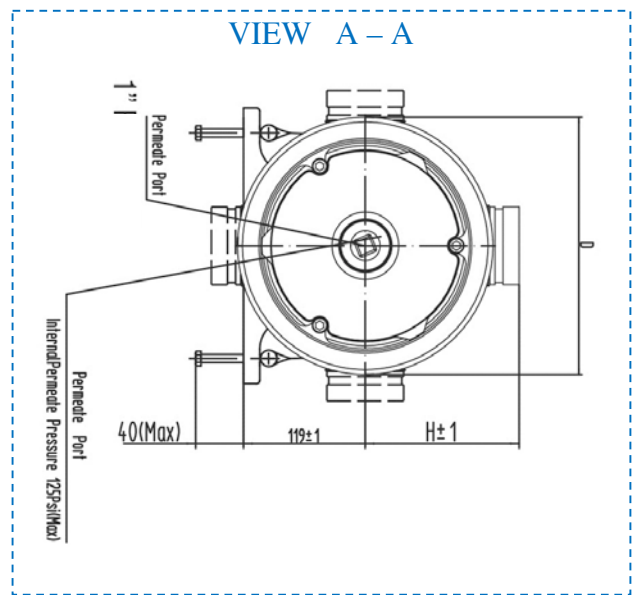
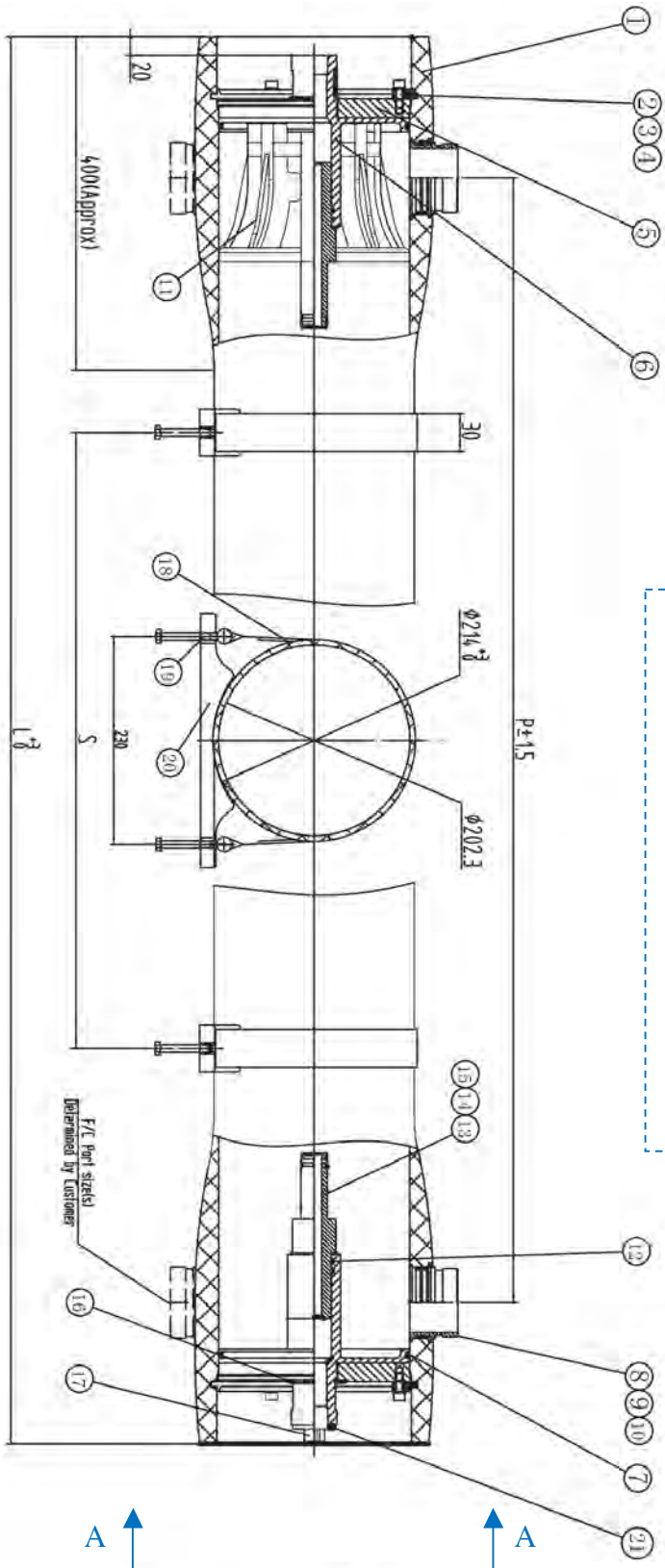

8" Membrane Vessels Side Port Series 600 S-8



- fiberglass reinforced plastic pressure vessels series 600 S-8, white painted, UVA-ray proof material;
- max operating pressure 600 psi (41 bar);
- European 97/23/EC Directive compliant for pressure equipment (PED);
- built in accordance with ASME code section X;
- D.M. n.174 dated 06/04/2004 compliant about materials suitable for contact with water for human consumption;
- each vessel is factory tested at 1,5 times max operating pressure;
- feed/concentrate connections 1 ½" Victaulic (optional 2", 2 ½" or 3") in super duplex steel AISI 2507;
- permeate connections 1" BSPT F;
- straps and saddles included (n.2 pcs from 1 to 3 elements, n.3 pcs from 4 to 7 elements);
- 1,125" membrane adapters included;
- version from 2 to 7 ports (see list of options).

REF. ORIENT. 0°	REF. ORIENT. 180°	MODEL	ELEMENTS	L (mm)	P (mm)	S (mm)	
H815D1 (*)	H817D1 (*)	600S-8-1	1 x 40"	1514	1143	700	
H815D2 (*)	H817D2 (*)	600S-8-2	2 x 40"	2530	2159	1460	
H815D3 (*)	H817D3 (*)	600S-8-3	3 x 40"	3546	3175	2080	
H815D4 (*)	H817D4 (*)	600S-8-4	4 x 40"	4562	4191	1600x2	
H815D5 (*)	H817D5 (*)	600S-8-5	5 x 40"	5578	5207	2000x2	
H815D6 (*)	H817D6 (*)	600S-8-6	6 x 40"	6594	6223	2360x2	
H815D7 (*)	H817D7 (*)	600S-8-7	7 x 40"	7610	7239	2860x2	

(*) not available in stock – Delivery 8-10 weeks.

8" Membrane Vessels Side Port Series 600 S-8

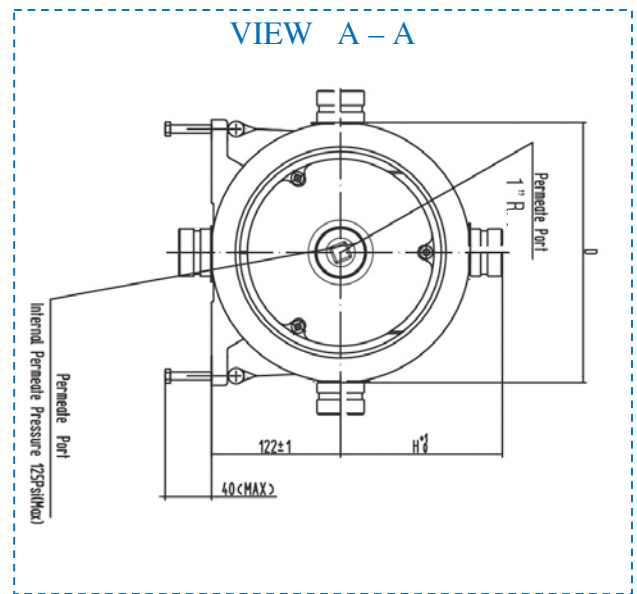
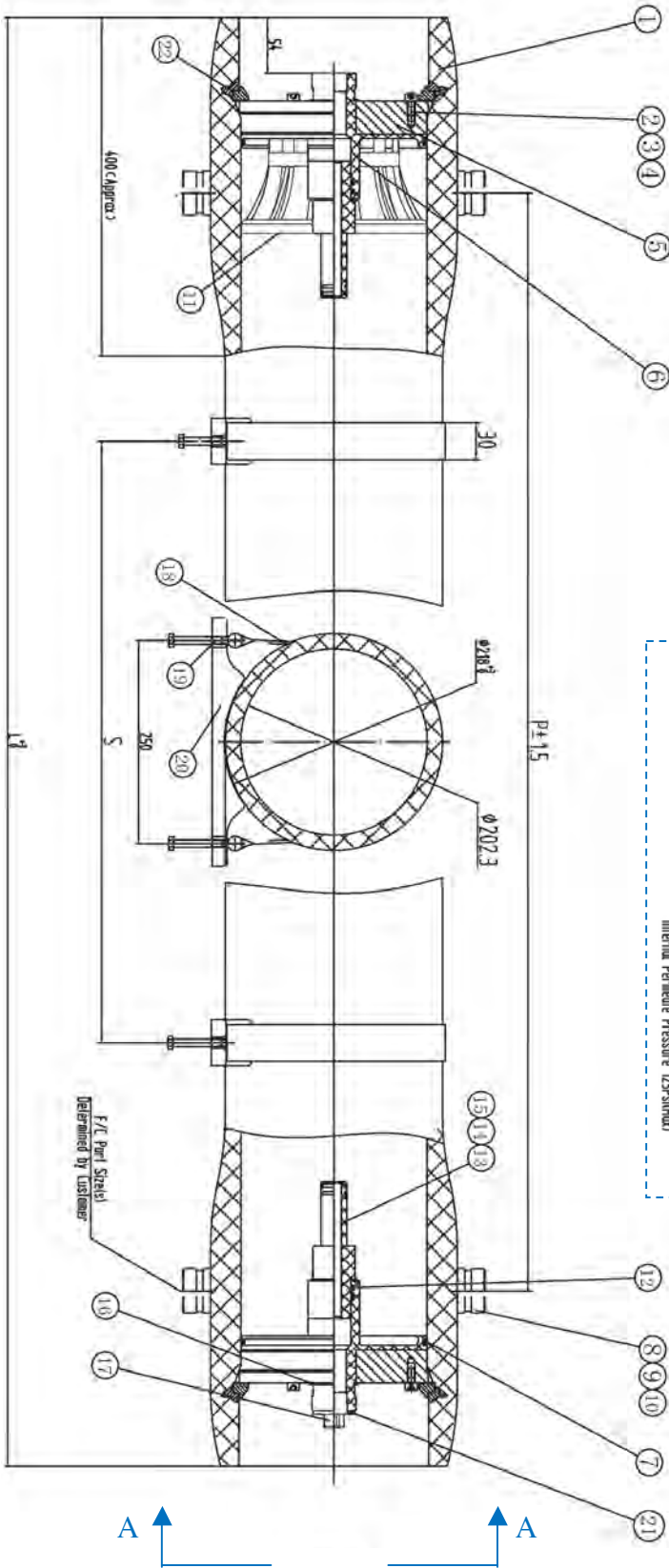

8" Membrane Vessels Side Port Series 1000 S-8



- fiberglass reinforced plastic pressure vessels series 600 S-8, white painted, UVA-ray proof material;
- max operating pressure 600 psi (41 bar);
- European 97/23/EC Directive compliant for pressure equipment (PED);
- built in accordance with ASME code section X;
- D.M. n.174 dated 06/04/2004 compliant about materials suitable for contact with water for human consumption;
- each vessel is factory tested at 1,5 times max operating pressure;
- feed/concentrate connections 1 ½" Victaulic (optional 2", 2 ½" or 3") in super duplex steel AISI 2507;
- permeate connections 1" BSPT F;
- straps and saddles included (n.2 pcs from 1 to 3 elements, n.3 pcs from 4 to 7 elements);
- 1,125" membrane adapters included;
- version from 2 to 7 ports (see list of options).

REF. ORIENT. 0°	REF. ORIENT. 180°	MODEL	ELEMENTS	L (mm)	P (mm)	S (mm)	
H815G1 (*)	H817G1 (*)	1000S-8-1	1 x 40"	1514	1143	700	
H815G2 (*)	H817G2 (*)	1000S-8-2	2 x 40"	2530	2159	1460	
H815G3 (*)	H817G3 (*)	1000S-8-3	3 x 40"	3546	3175	2080	
H815G4 (*)	H817G4 (*)	1000S-8-4	4 x 40"	4562	4191	1600x2	
H815G5 (*)	H817G5 (*)	1000S-8-5	5 x 40"	5578	5207	2000x2	
H815G6 (*)	H817G6 (*)	1000S-8-6	6 x 40"	6594	6223	2360x2	
H815G7 (*)	H817G7 (*)	1000S-8-7	7 x 40"	7610	7239	2860x2	

(*) not available in stock – Delivery 8-10 weeks.

8" Membrane Vessels Side Port Series 1000 S-8

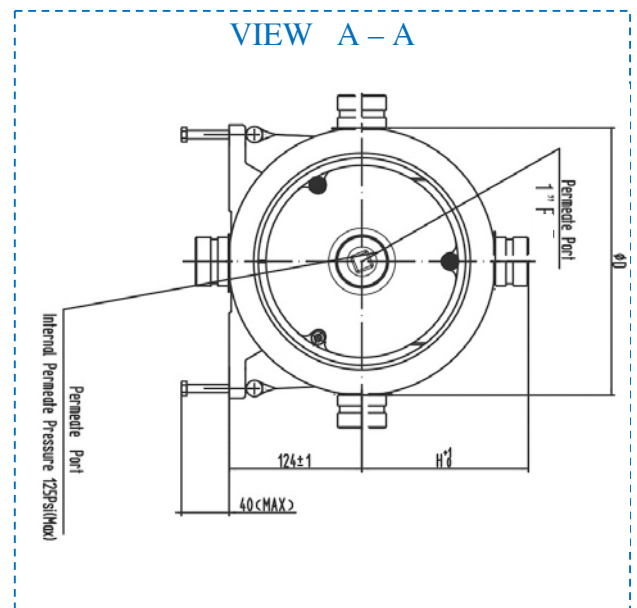
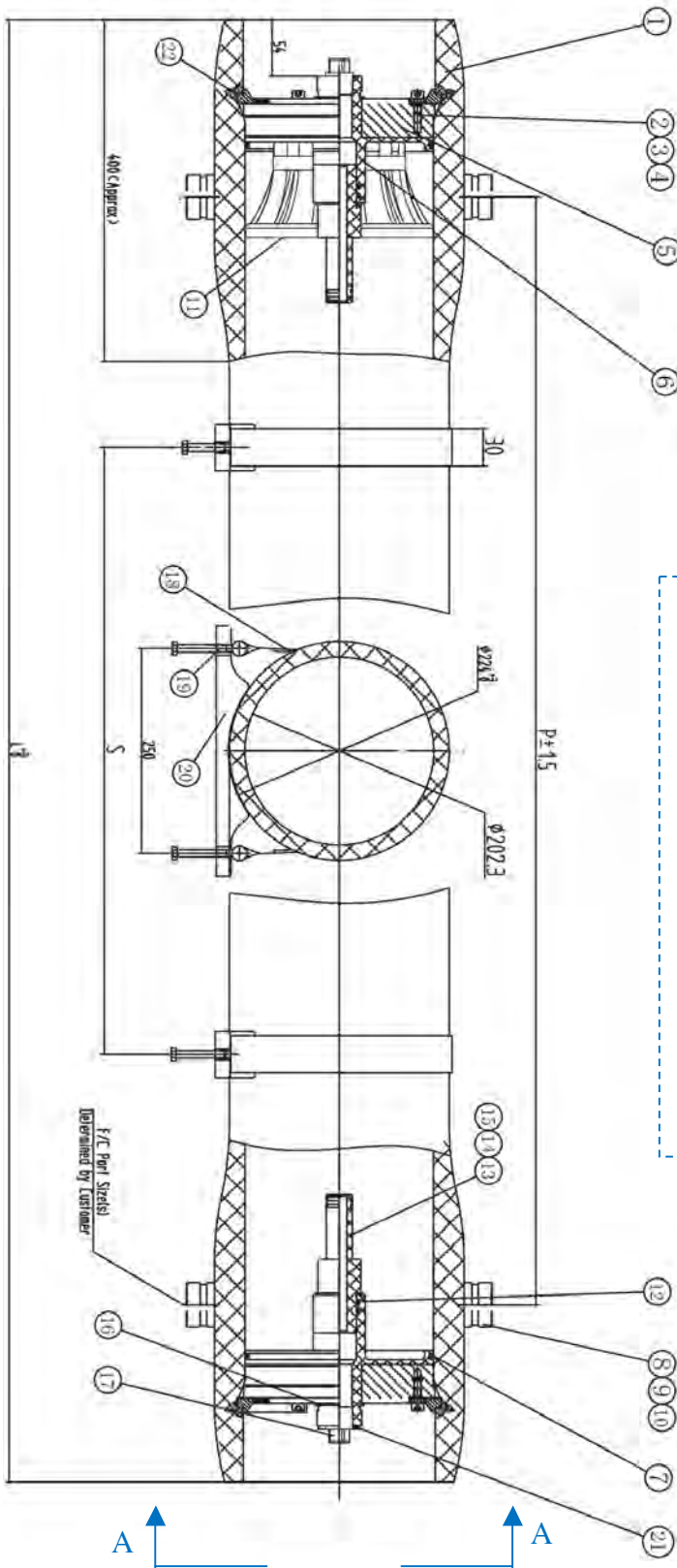

8" Membrane Vessels Side Port Series 1200 S-8



- fiberglass reinforced plastic pressure vessels series 1200 S-8, white painted, UVA-ray proof material;
- max operating pressure 1200 psi (83 bar);
- European 97/23/EC Directive compliant for pressure equipment (PED);
- built in accordance with ASME code section X;
- D.M. n.174 dated 06/04/2004 compliant about materials suitable for contact with water for human consumption;
- each vessel is factory tested at 1,5 times max operating pressure;
- feed/concentrate connections 1 ½" Victaulic (optional 2", 2 ½" or 3") in super duplex steel AISI 2507;
- permeate connections 1" BSPT F;
- straps and saddles included (n.2 pcs from 1 to 3 elements, n.3 pcs from 4 to 7 elements);
- 1,125" membrane adapters included;
- version from 2 to 7 ports (see list of options).

REF. ORIENT. 0°	REF. ORIENT. 180°	MODEL	ELEMENTS	L (mm)	P (mm)	S (mm)	
H815H1 (*)	H817H1 (*)	1200S-8-1	1 x 40"	1514	1143	700	
H815H2 (*)	H817H2 (*)	1200S-8-2	2 x 40"	2530	2159	1460	
H815H3 (*)	H817H3 (*)	1200S-8-3	3 x 40"	3546	3175	2080	
H815H4 (*)	H817H4 (*)	1200S-8-4	4 x 40"	4562	4191	1600x2	
H815H5 (*)	H817H5 (*)	1200S-8-5	5 x 40"	5578	5207	2000x2	
H815H6 (*)	H817H6 (*)	1200S-8-6	6 x 40"	6594	6223	2360x2	
H815H7 (*)	H817H7 (*)	1200S-8-7	7 x 40"	7610	7239	2860x2	

(*) not available in stock – Delivery 8-10 weeks.

8" Membrane Vessels Side Port Series 1200 S-8

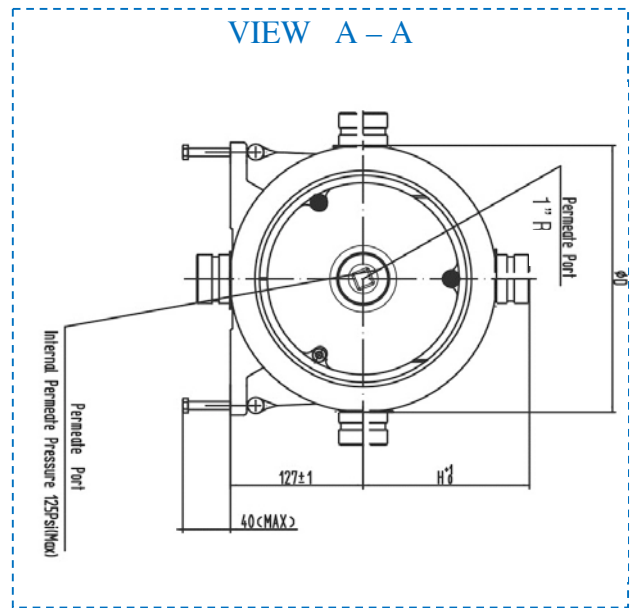
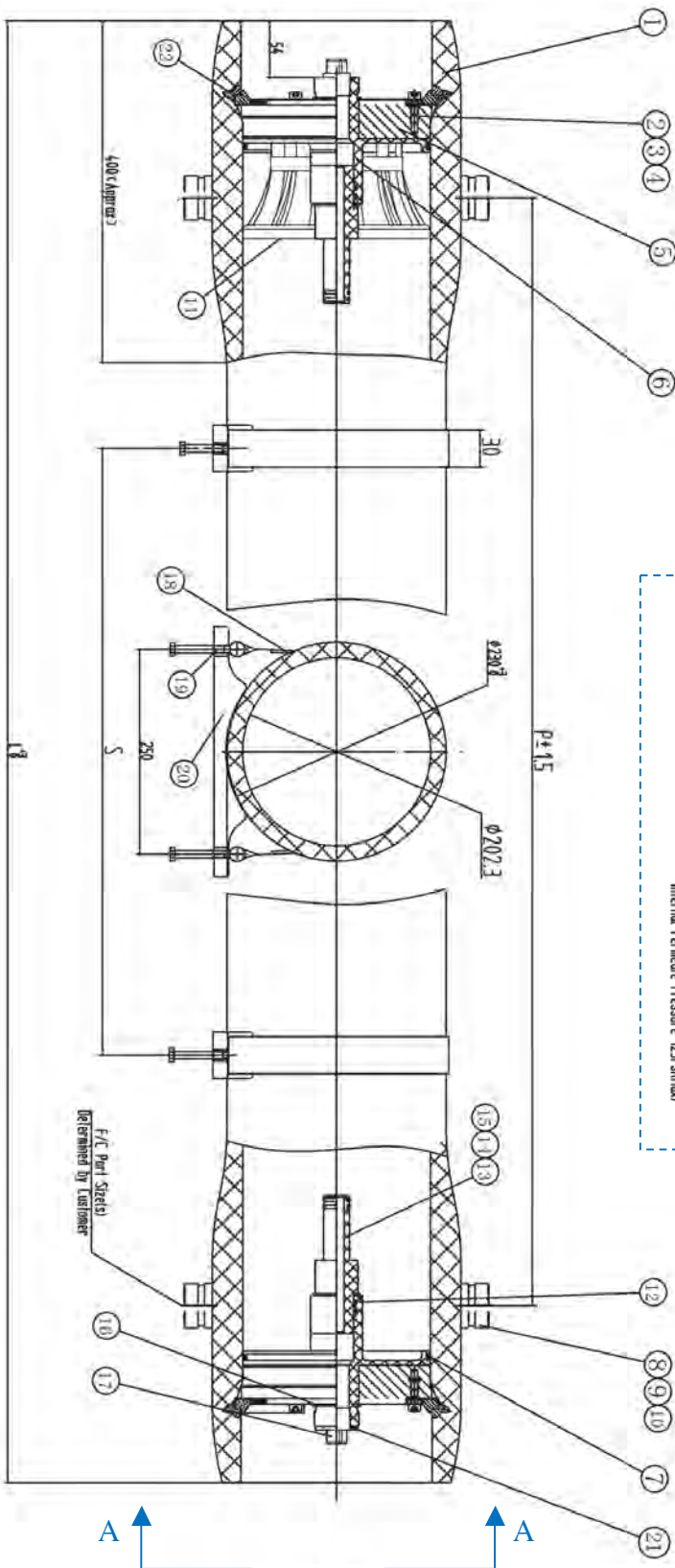

8" Side Port 300-450 Psi Vessels Spare Parts

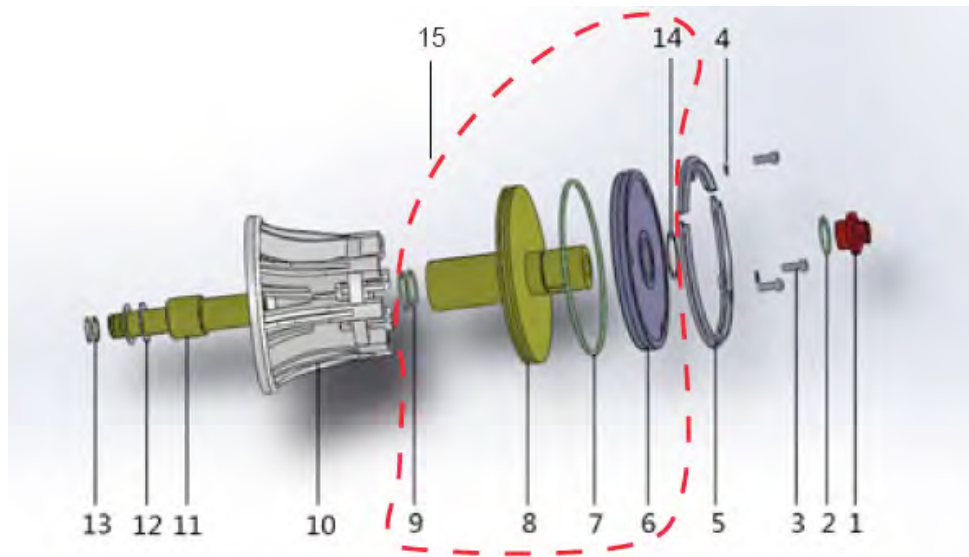

ITEM	REF.	DESCRIPTION	MATERIAL	
1	H8R081	PLUG	ABS	
2	H8R111	PWT SEAL	EPDM	
3	H8R203	LOCKING SEGMENT SCREW	AISI 304	
4	H8R031	SPRING PAD	AISI 304	
5	H8R041	LOCKING SEGMENT	AISI 304	
7	H8R107	HEAD SEAL	EPDM	
9	H8R111	PWT SEAL	EPDM	
10	H8R071	THRUST CONE	ABS	
11 + 13	H8R601	1,125" ADAPTER	ABS	
	H8R611	1,5" ADAPTER (OPTIONAL)	ABS	
12	H8R651	1,125" ADAPTER PAD	ABS	
	H8R653	1,5" ADAPTER PAD (OPTIONAL)	ABS	
13	H8R113	1,125" ADAPTER O-RING	EPDM	
	H8R115	1,5" ADAPTER O-RING (OPTIONAL)	EPDM	
15	H8R711	HEAD ASSEMBLY SIDE PORT 300 PSI		
	H8R713	HEAD ASSEMBLY SIDE PORT 450 PSI		
NOT SHOWN	H8R001	SADDLE	RUBBER	
NOT SHOWN	H8R005	STRAP (L = 520 mm)	AISI 304 - RUBBER	

8" Side Port 600-1000-1200 Psi Vessels Spare Parts

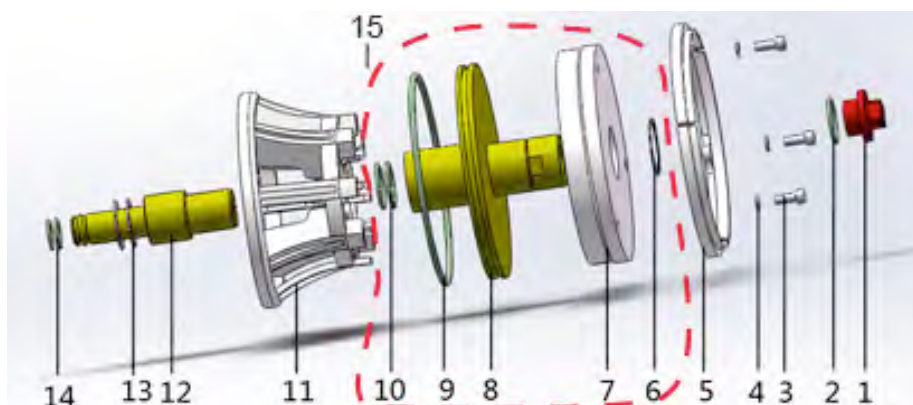

ITEM	REF.	DESCRIPTION	MATERIAL	
1	H8R081	PLUG	ABS	
2	H8R111	PWT SEAL	EPDM	
3	H8R203	LOCKING SEGMENT SCREW	AISI 304	
4	H8R031	SPRING PAD	AISI 304	
5	H8R045	LOCKING KIT (N.3 SEGMENTS)	AISI 304	
8		SEALING PLATE (PERMEATE PORT)	ABS	
9	H8R107	HEAD SEAL	EPDM	
10	H8R111	PWT SEAL	EPDM	
11	H8R073	THRUST CONE	ABS	
12 + 14	H8R603	1,125" ADAPTER	ABS	
	H8R613	1,5" ADAPTER (OPTIONAL)	ABS	
13	H8R651	1,125" ADAPTER PAD	ABS	
	H8R653	1,5" ADAPTER PAD (OPTIONAL)	ABS	
14	H8R113	1,125" ADAPTER O-RING	EPDM	
	H8R115	1,5" ADAPTER O-RING (OPTIONAL)	EPDM	
15	H8R715	HEAD ASSEMBLY SIDE PORT 600 PSI		
	H8R717	HEAD ASSEMBLY SIDE PORT 1000 PSI		
	H8R719	HEAD ASSEMBLY SIDE PORT 1200 PSI		
NOT SHOWN	H8R001	SADDLE	RUBBER	
NOT SHOWN	H8R009	STRAP (L = 580 mm)	AISI 304 - RUBBER	

8" Membrane Adapters



- suitable for 8" membranes;
- material PVC complete with o-rings.

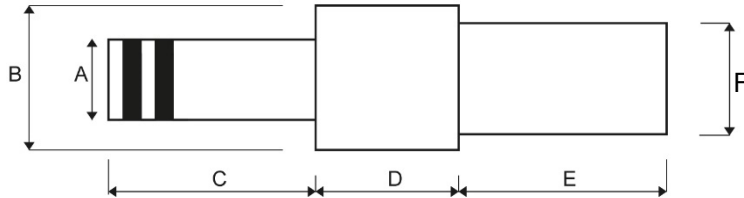

REF.	MATERIAL	A *	B *	C *	D *	E *	F *	FOR MEMBR.	FOR VESSEL	REF. O-RING
H8R601	ABS	28,3 (1,125")	46	70	38	70	36,5	BW30-400 or similar	MWG	H8R113
H8R611	ABS	38 (1,5")	50	70	36	70	36,55	BW30LE440 or similar	MWG	H8R115
H8R603	ABS	28,3 (1,125")	46	70	38	53	36,5	BW30-400 or similar	MWG	H8R113
H8R613	ABS	38 (1,5")	50	70	36	53	36,55	BW30LE440 or similar	MWG	H8R115
EA340	ABS	28,5 (1,125")	48	65	45	67	36,7	BW30-400 or similar	Wave Cyber	EA354
EA341	ABS	38 (1,5")	58	50	45	67	36,7	BW30LE440 or similar	Wave Cyber	EA355
EA025	PVC	28,5 (1,125")	48	65	27	73	36,7	BW30-400 or similar	Codeline Style	EA354

* Dimensions: mm (inch)

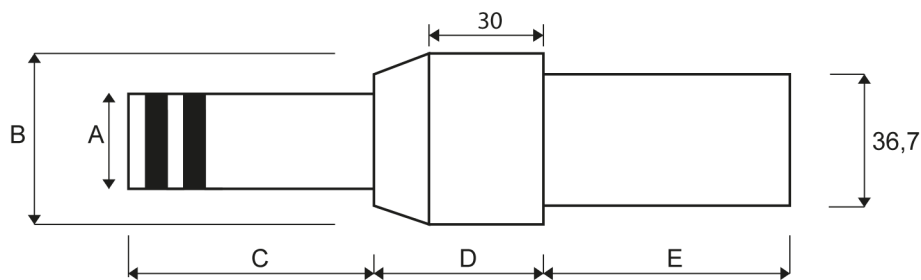

REF.	MATERIAL	A *	B *	C *	D *	E *	FOR MEMBR.	FOR VESSEL	REF. O-RING
EA023	PVC	28,5 (1,125")	50	73	50	64	BW30-400 or similar	Bekaert Style	EA354

* Dimensions: mm (inch)



Blank Adapter Kit

- suitable for 8" membranes;
- material PVC complete with o-rings.

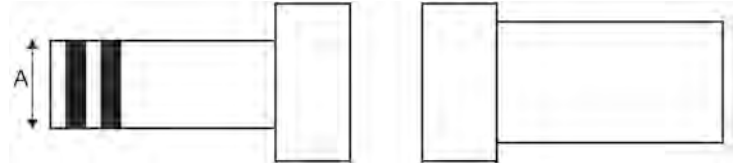

REF.		A (mm)	A (inch)	FOR MEMBRANE	FOR VESSEL	O-RING REF.
EA026		28,5	1,125"	BW30-400 or similar	Wave Cyber	EA264
EA026A		28,5	1,125"	BW30-400 or similar	MWG	EA264

Blank Adapter

- Material PVC.

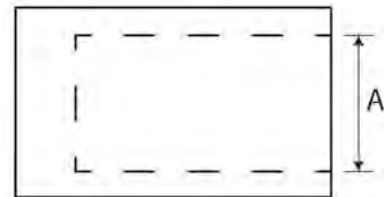

REF.		A (mm)	A (inch)	FOR MEMBRANE
EA028		28,5	1,125"	BW30-400 or similar

Closure disc for permeate connection for 8" vessels

- material PVC.

REF.	
EA350	

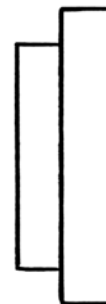



Cast Iron Victaulic Style Couplings – 1000 Psi

- complete with gaskets;
- max operating pressure 1000 psi (69 bar).

REF.	NOMINAL DIAMETER (inch)	NOMINAL DIAMETER (mm)	
EA030	1"	33,4	
EA032	1 ¼"	42,2	
EA031	1 ½"	48,3	
EA033	2"	60,3	
EA034	2 ½"	73,0	
EA035	3"	88,9	



Aisi 304 Victaulic Style Couplings – 1200 Psi

- complete with gaskets;
- max operating pressure 1200 psi (83 bar).

REF.	NOMINAL DIAMETER (inch)	NOMINAL DIAMETER (mm)	
EA190	¾"	26,7	
EA191	1"	33,4	
EA192	1 ¼"	42,2	
EA193	1 ½"	48,3	
EA194	2"	60,3	
EA195	2 ½"	73,0	
EA196	3"	88,9	



Aisi 304 Victaulic Style Couplings – 350 Psi

- complete with gaskets;
- max operating pressure 1350 psi (23 bar).

REF.	NOMINAL DIAMETER (inch)	NOMINAL DIAMETER (mm)	
EA070	¾"	26,7	
EA071	1"	33,4	
EA072	1 ¼"	42,2	
EA073	1 ½"	48,3	
EA074	2"	60,3	
EA075A	2 ½"	73,0	
EA075	3" O. D.	76,1	
EA076	3"	88,9	





Stub Pipes to Weld

- stub pipe with end part to weld;
- material AISI 316.

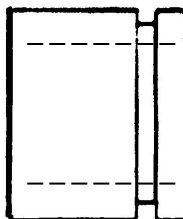

REF.	ANSI B36.10 SCHEDULE	DIAMETER (inch)	DIAMETER (mm)	LENGTH (mm)	
EA080	40	¾"	26,7	40	
EA081	40	1"	33,4	40	
EA082	40	1 ¼"	42,2	50	
EA083	40	1 ½"	48,3	60	
EA084	40	2"	60,3	80	
EA085A	40	2 ½"	73,0	90	
EA086	40	3"	88,9	100	

Threaded Stub Pipes

- stub pipe with end part thread
- material AISI 316.

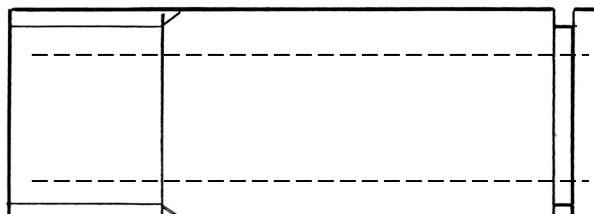

REF.	DIAMETER (inch)	LENGTH (mm)	
EA050	¾" BSPP male	65	
EA051	1" BSPP male	65	
EA052	1 ¼" BSPP male	80	
EA053	1 ½" BSPP male	100	
EA054	2" BSPP male	100	
EA055	2 ½" BSPP male (external diameter 76,1 mm)	100	

R.O.PLUS Electric Control Panel for R.O. Systems



- With double conductivity meter (feed and permeate);
- In this way you can:
 - Command the high pressure pump and the two solenoid valves for feed interception and flushing;
 - Manage and program the most common measurement and signal instruments installed on the system, with highly flexible ways of working;
 - Manage and setting the automatic cleaning system;
- Conform to CE Directives;
- Microprocessor;
- LCD display 2 x 16 digit;
- Power supply 230VAC 50-60Hz;
- Protection class IP65;
- Supplied without conductivity probes.

Operated functions:

- High pressure pump (max power 736 W);
- Feed electric valve;
- Fluxing electric valve;
- Cleaning electric valve;
- Pump for antiscaling.



Conductivity meter:

RO PLUS is available in the following 2 versions (supplied without conductivity probes):

VERSION 1 : RO PLUS LC (ref. DG101)

With conductivity meter for feed $000 \div 9,99$ mS/cm
and conductivity meter for $00,0 \div 99,9$ μ S/cm

Warning: with this model you must use one Inox probe K=1 (ref. **DG121**) for the feed and one Inox probe K=0.1 for the out let (ref. **DG122**), to buy separately.

VERSION 2 : RO PLUS HC (ref. DG103)

With conductivity meter for feed $00,0 \div 9,99$ mS/cm
and conductivity meter for $00,0 \div 999$ μ S/cm

Warning: with this model you must use n.2 graphite probes K=1 (ref. DG123), one for the feed and one for the out let, to buy separately.

The version is displayed turning on the instrument.

R.O.PLUS Electric Control Panel for R.O. Systems



External input receivable:

- Low permeate storage tank level;
- High permeate storage tank level;
- Minimum pressure meter;
- Maximum pressure meter;
- Pretreatment (filter or softener) in service;
- Heat pump;
- Failed dosage alarm;
- Stand-by.

Alarms:

- High conductivity;
- Low pressure;
- High pressure;
- Heat pump;
- HIGH LOW CONTACT.

(*) not available in stock.

REF.	DESCRIPTION	
DG101	RO PLUS LC	
DG103 (*)	RO PLUS HC	
DG121	Inox probe K=1, 3/4" connection	
DG122	Inox probe K=0.1, 3/4" connection	
DG123 (*)	Graphite probe K=1, 3/4" connection	



REF.
DG121



REF.
DG122

In-Out 3/8" Rotary Pumps for R.O.



- rotary vane pumps for R.O. systems, direct connection V-band clamp to motor;
- housing material brass or AISI 303, security by-pass on show models;
- IN-OUT connections 3/8" F BSPT (or NPT on demand).

Brass Pumps

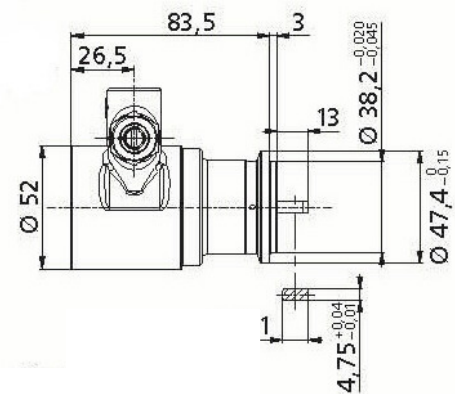
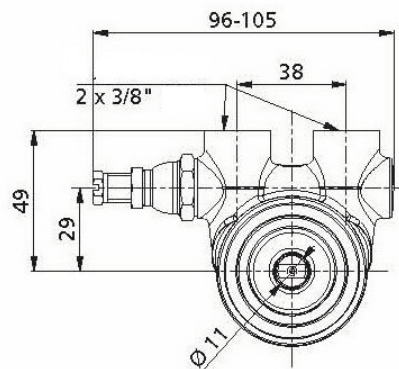

Aisi 303 Pumps

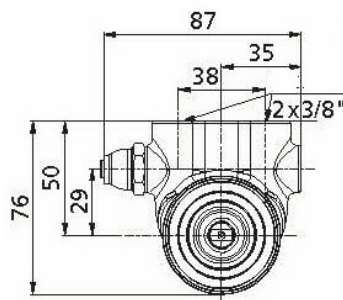

Dimensions are in mm

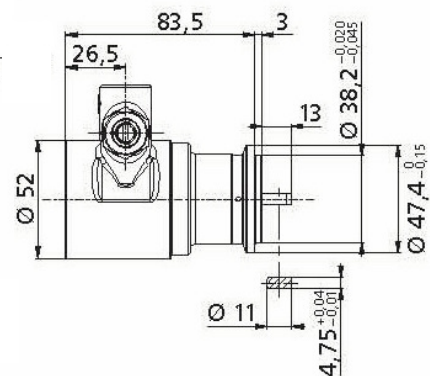

In-Out 3/8" Rotary Pumps for R.O.



REF.	MODEL	CONNECTIONS	BY-PASS	MATERIAL	FLOW * @ 7 bar (l/h)	FLOW * @ 14 bar (l/h)	
DE804A	RO 50 OT	BSPT	w/ By-Pass	Brass	65	55	
DE805A	RO 150 OT	BSPT	w/ By-Pass	Brass	165	150	
DE806A	RO 200 OT	BSPT	w/ By-Pass	Brass	225	206	
DE807A	RO 300 OT	BSPT	w/ By-Pass	Brass	334	315	
DE808A	RO 400 OT	BSPT	w/ By-Pass	Brass	434	415	
DE827A	RO 300 AISI	BSPT	w/ By-Pass	AISI 303	334	315	
DE828A	RO 400 AISI	BSPT	w/ By-Pass	AISI 303	434	415	
DE811A	RO 200 OT	BSPT	w/o By-Pass	Brass	225	206	
DE812A	RO 300 OT	BSPT	w/o By-Pass	Brass	334	315	
DE813A	RO 400 OT	BSPT	w/o By-Pass	Brass	434	415	
DE832A	RO 300 AISI	BSPT	w/o By-Pass	AISI 303	334	315	
DE833A	RO 400 AISI	BSPT	w/o By-Pass	AISI 303	434	415	
DE804 (*)	RO 50 OT	NPT	w/ By-Pass	Brass	65	55	
DE805 (*)	RO 150 OT	NPT	w/ By-Pass	Brass	165	150	
DE806 (*)	RO 200 OT	NPT	w/ By-Pass	Brass	225	206	
DE807 (*)	RO 300 OT	NPT	w/ By-Pass	Brass	334	315	
DE808 (*)	RO 400 OT	NPT	w/ By-Pass	Brass	434	415	
DE827 (*)	RO 300 AISI	NPT	w/ By-Pass	AISI 303	334	315	
DE828 (*)	RO 400 AISI	NPT	w/ By-Pass	AISI 303	434	415	
DE811 (*)	RO 200 OT	NPT	w/o By-Pass	Brass	225	206	
DE812 (*)	RO 300 OT	NPT	w/o By-Pass	Brass	334	315	
DE813 (*)	RO 400 OT	NPT	w/o By-Pass	Brass	434	415	
DE832 (*)	RO 300 AISI	NPT	w/o By-Pass	AISI 303	334	315	
DE833 (*)	RO 400 AISI	NPT	w/o By-Pass	AISI 303	434	415	

(*) not available in stock.

(**) average flow rate with motor 1.450 rpm.

In-Out 1/2" Rotary Pumps for R.O.



- rotary vane pumps for R.O. systems, direct connection V-band clamp to motor;
- housing material brass or AISI 303;
- IN-OUT Gas connections 1/2" F BSPT (or NPT on demand).

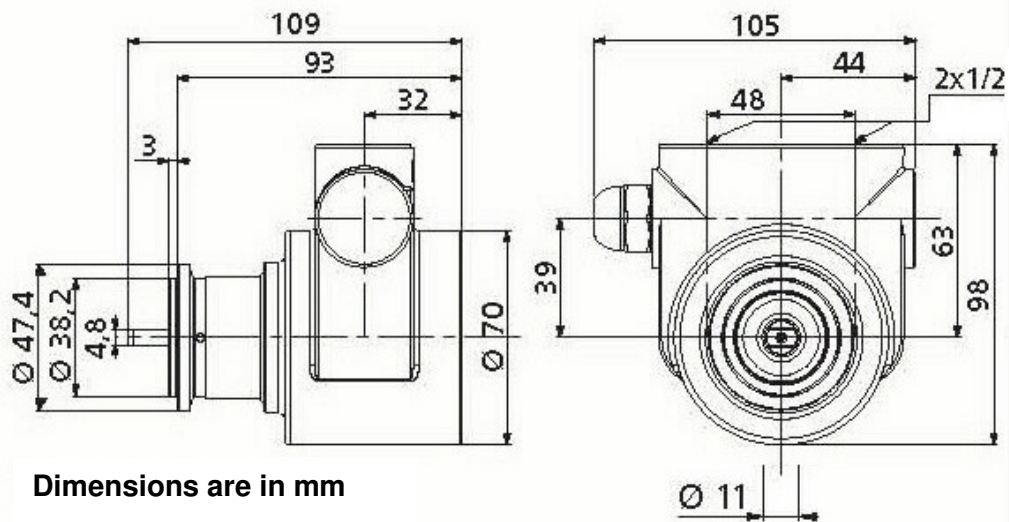

In-Out 1/2" Rotary Pumps for R.O.



REF.	MODEL	CONNECTIONS	BY-PASS	MATERIAL	FLOW * @ 7 bar (l/h)	FLOW * @ 14 bar (l/h)	
DE809A	RO 600 OT	BSPT	w/ By-Pass	Brass	620	597	
DE810A	RO 800 OT	BSPT	w/ By-Pass	Brass	820	797	
DE814A	RO 1000 OT	BSPT	w/ By-Pass	Brass	1020	997	
DE817A	RO 600 OT	BSPT	w/o By-Pass	Brass	620	597	
DE818A	RO 800 OT	BSPT	w/o By-Pass	Brass	820	797	
DE819A	RO 1000 OT	BSPT	w/o By-Pass	Brass	1020	997	
DE801A	RO 600 AISI	BSPT	w/ By-Pass	AISI 303	620	597	
DE802A	RO 800 AISI	BSPT	w/ By-Pass	AISI 303	820	797	
DE803A	RO 1000 AISI	BSPT	w/ By-Pass	AISI 303	1020	997	
DE837A	RO 600 AISI	BSPT	w/o By-Pass	AISI 303	620	597	
DE838A	RO 800 AISI	BSPT	w/o By-Pass	AISI 303	820	797	
DE839A	RO 1000 AISI	BSPT	w/o By-Pass	AISI 303	1020	997	
DE809 (*)	RO 600 OT	NPT	w/ By-Pass	Brass	620	597	
DE810 (*)	RO 800 OT	NPT	w/ By-Pass	Brass	820	797	
DE814 (*)	RO 1000 OT	NPT	w/ By-Pass	Brass	1020	997	
DE817 (*)	RO 600 OT	NPT	w/o By-Pass	Brass	620	597	
DE818 (*)	RO 800 OT	NPT	w/o By-Pass	Brass	820	797	
DE819 (*)	RO 1000 OT	NPT	w/o By-Pass	Brass	1020	997	
DE801 (*)	RO 600 AISI	NPT	w/ By-Pass	AISI 303	620	597	
DE802 (*)	RO 800 AISI	NPT	w/ By-Pass	AISI 303	820	797	
DE803 (*)	RO 1000 AISI	NPT	w/ By-Pass	AISI 303	1020	997	
DE837 (*)	RO 600 AISI	NPT	w/o By-Pass	AISI 303	620	597	
DE838 (*)	RO 800 AISI	NPT	w/o By-Pass	AISI 303	820	797	
DE839 (*)	RO 1000 AISI	NPT	w/o By-Pass	AISI 303	1020	997	

(*) not available in stock.

(**) average flow rate with motor 1.450 rpm.

Motors for Rotary Pumps for R.O. 200-300



- single phase motors direct connections for rotary vane pumps;
- power supply 220V – 50 Hz;
- protection class IP44;
- complete with thermic protection.

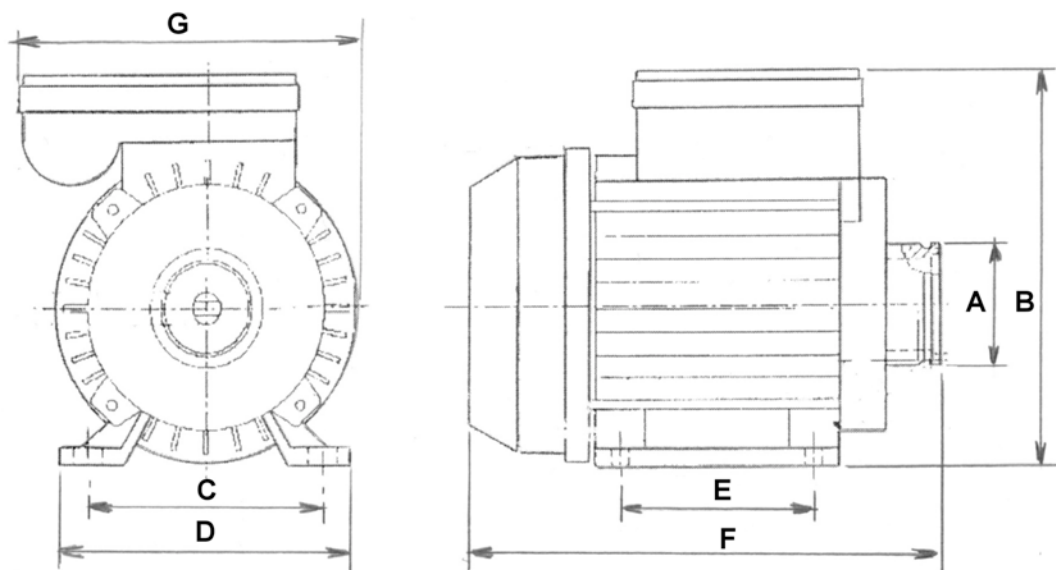

REF.	A (mm)	B (mm)	C (mm)	D (mm)	E (mm)	F (mm)	G (mm)
DE850	47	156	97	120	80	200	138

REF.	POWER (W)	ELECTR. INPUT (A)	RPM	FOR PUMPS	
DE850	300	1,6	1.300	RO 200 RO 300	

Motors for Rotary Pumps for R.O. 300-400-600-800-1000



- range of single and three phase motors for application with rotary vane pumps, using coupling and adapter;
- 4 poles motor, power supply 220V – 50 Hz single phase, 380V – 50 Hz three phase;
- protection class IP55;
- for couplings and adapters see 06-04-08-EN data sheet.

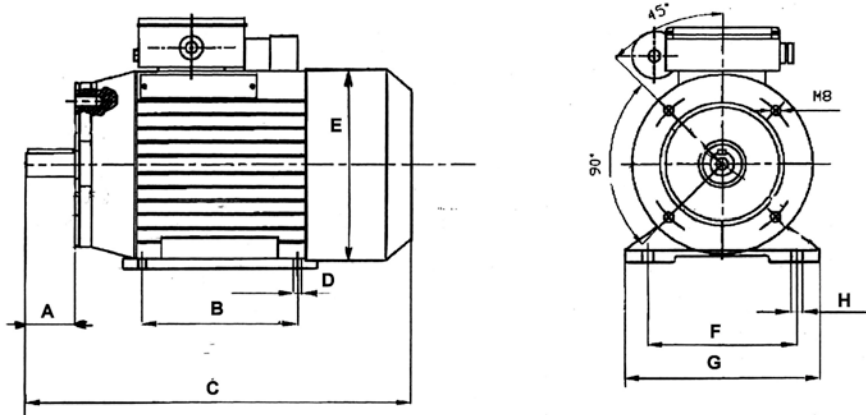

REF.	A (mm)	B (mm)	C (mm)	D (mm)	E (mm)	F (mm)	G (mm)	H (mm)
0,5 CV	30	90	222	7	141	112	142	10
0,75 CV	40	100	255	10	157	125	160	13
1 CV	40	100	255	10	157	125	160	13

REF.	DE860	DE861	DE862	DE863	DE864	DE865
MODEL	0,5 CV-M71-MONO	0,75 CV-M80-MONO	1 CV-M80-MONO	0,5 CV-M71-TRI	0,75 CV-M80-TRI	1 CV-M80-TRI
POWER (CV)	0,5	0,75	1	0,5	0,75	1
POWER (W)	370	550	750	370	550	750
ELECTR. INPUT (A)	3,1	3,9	5,6	2,2	2,8	3,5
RPM	1360	1360	1370	1360	1360	1360
SINGLE PHASE/ THREE PHASE	SINGLE PHASE	SINGLE PHASE	SINGLE PHASE	THREE PHASE	THREE PHASE	THREE PHASE
FOR PUMP	RO 300 RO 400	RO 600 RO 800	RO 1000	RO 300 RO 400	RO 600 RO 800	RO 1000
ADAPTER REF	DE871	DE873	DE873	DE871	DE873	DE873
COUPLING REF.	DE872	DE874	DE874	DE872	DE874	DE874

Adapter Couplings and Adapters for Rotary Pumps Models R.O. 300-400-600-800-1000



- for relative motors coupling see 06-04-07-EN data sheet.

REF.	DESCRIPTION	
DE871	Adapter M71	

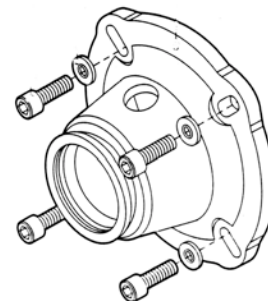

REF.	DESCRIPTION	
DE873	Adapter M80	

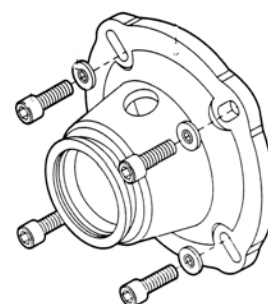

REF.	DESCRIPTION	
DE872	Coupling M71	

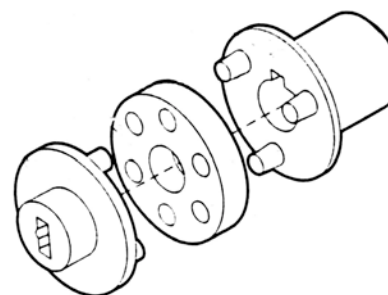

REF.	DESCRIPTION	
DE874	Coupling M80	

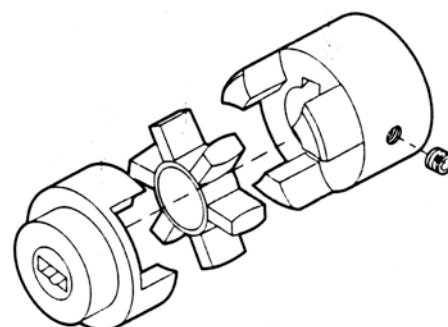

Flowmeters



- Flowmeters (the reading is taken in correspondence with the top edge of the float) with wide range of measuring scale and of end connections (d20 ÷ d75), good level of accuracy with simple operation and very limited maintenance;
- Standard fluid = water;
- Measuring tube in transparent PVC-U, Float in PP and O-ring in EPDM;
- Isolating or control valves may be mounted both upstream or downstream the flowmeter;
- Maximum working pressure with water up to 25°C = 10 bar;
- Maximum working pressure with water up to 60°C = 1,5 bar
- Temperature range = 5 ÷ 60°C.

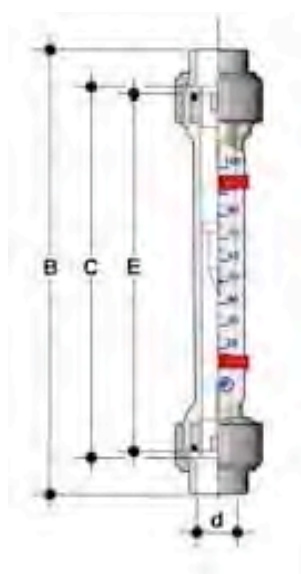

FCIV

d	B	C	E
20	208	176	170
25	229	191	185
32	250	206	200

FSIV

d	B	C	E
40	408	356	350
63	432	356	350
75	444	356	350



REF.	MODEL	MEASURING RANGE (L/H)	CONNECTION	
DG030	FCIV	20 ÷ 200	d20	
DG032	FCIV	30 ÷ 350	d25	
DG034	FCIV	60 ÷ 600	d32	
DG036	FCIV	100 ÷ 1.000	d32	
DG038	FSIV	160 ÷ 1.600	d40	
DG040	FSIV	200 ÷ 2.500	d40	
DG042	FSIV	350 ÷ 3.500	d63	
DG044	FSIV	500 ÷ 5.000	d63	
DG046	FSIV	1.000 ÷ 8.000	d75	
DG048	FSIV	1.000 ÷ 10.000	d75	
DG050	FSIV	5.000 ÷ 25.000	d75	



ACCESSORIES:

- Threaded connections not included, to order separately;
- Material not available in stock.

REF.	DESCRIPTION	FOR FLOWMETER	
DG061	BFV THREADED COUPLING BSP 1/2" PVC-U	DG030	
DG063	BFV THREADED COUPLING BSP 3/4" PVC-U	DG032	
DG065	BFV THREADED COUPLING BSP 1" PVC-U	DG034 – DG036	
DG067	BFV THREADED COUPLING BSP 1 1/4" PVC-U	DG038 – DG040	
DG069	BFV THREADED COUPLING BSP 2" PVC-U	DG042 – DG044	
DG071	BFV THREADED COUPLING BSP 2 1/2" PVC-U	DG046 – DG048 –DG050	

Accessories and Spare Parts 2,5" WAVE CYBER Vessels



REF.	DESCRIPTION
DE510	Plastic clip for 2,5" vessels
DE420	Baffle 300 psi
DE421	Head 300 psi
DE422	Head seal
DE423	Allen screw
DE424	Baffle 1000 psi
DE425	Head 1000 psi

Accessories and Spare Parts 4" WAVE CYBER Vessels



REF.	DESCRIPTION	
DE610	Saddle and strap assembly	
DE613	Baffle	
DE614	Head ½" BSPP (300 psi) PP/FG	
DE618	Head ¾" BSPP (300 psi) PP/FG	
DE614A	Head ½" BSPP (450 psi) nylon	
DE618A	Head ¾" BSPP (450 psi) nylon	
DE615	Head seal	
DE616	Adapter seal	
DE617	Allen screw	

Spare Parts for 8" End Port WAVE CYBER Vessels



REF.	DESCRIPTION	
EA392	Head Assembly H "E Series" 250-300 psi p/n 70531	
EA393	Head Assembly H "E Series" 400-450 psi p/n 70532	
EA394	Head Assembly H "E Series" 600 psi p/n 70533	
EA395	Head Assembly H "E Series" 1000-1200 psi p/n 70534	
EA371	Three-turn locking ring 150-600 psi	
EA371A	Three-turn locking ring 1000-1200 psi	
EA372	Permeate port retaining ring	
EA375	Bearing plate 300 psi	
EA376	Bearing plate 400-450 psi	
EA377	Bearing plate 600 psi	
EA378	Bearing plate 1000 psi	
EA358	Head seal	
EA367	Permeate port H 300 psi	
EA368	Permeate port H 400-450 psi	
EA369	Permeate port H 600 psi	
EA370	Permeate port H 1000 psi	
EA356	PWT seal	
EA365	Thrust cone	
EA361	Feed / concentrate port 300 psi	
EA362	Feed / concentrate port 400-450 psi	
EA363	Feed / concentrate port 600 psi	
EA364	Feed / concentrate port 1000 psi	
EA379	Retaining ring 300 psi	
EA380	Retaining ring 400-450 psi	
EA381	Retaining ring 600 psi	
EA382	Retaining ring 1000 psi	
EA357	Feed / concentrate port seal	
EA373	Strap	
EA374	Saddle	
EA347	Permeate nut 1 1/2" G	
EA348	Permeate adapter D32 to glue	
EA351	Permeate port H o-ring	
EA351A	Permeate port H flat gasket	

Spare Parts for 8" Side Port WAVE CYBER Vessels



REF.	DESCRIPTION	
EA492	Head Assembly H –“P Series” 300 psi p/n 70525	
EA493	Head Assembly H –“P Series” 450 psi p/n 70526	
EA494	Head Assembly H –“P Series” 600 psi p/n 70527	
EA495	Head Assembly H –“P Series” 1000 psi p/n 70528	
EA496	Head Assembly H –“P Series” 1200 psi p/n 70529	
EA371	Three-turn locking ring 150-600 psi	
EA371A	Three-turn locking ring 1000-1200 psi	
EA372	Permeate port retaining ring	
EA471	Bearing plate 300 psi	
EA472	Bearing plate 450 psi	
EA473	Bearing plate 600 psi	
EA474	Bearing plate 1000 psi	
EA476	Permeate port H 300 psi	
EA477	Permeate port H 450 psi	
EA478	Permeate port H 600 psi	
EA479	Permeate port H 1000 psi	
EA358	Head seal	
EA356	PWT seal	
EA480	Thrust cone	
EA373	Strap	
EA374	Saddle	
EA347	Permeate nut 1 ½” G	
EA348	Permeate adapter D32 to glue	
EA351	Permeate port H o-ring	
EA351A	Permeate port H flat gasket	

PL Series Metering Pumps Horizontal Mounting



- PL series metering pumps horizontal mounting;
- Constant or proportional feeding, with pulse multiplier or pulse divider, dosage based on a mA signal or a digital signal (from 1 pulse/minute at 180 pulses/minute);
- Microprocessor technology;
- Manual stroke length adjustment;
- Body pump's in PVDF (and o-rings in VITON) or PP (and o-rings in EPDM), with manual venting;
- Black enclosure in PP material;
- Protection class IP65;
- Audible noise 73,4 dB(A);
- Environment temperature 10 ÷ 45 °C;
- Chemical temperature 0 ÷ 50 °C;
- Power supply 230Vac 50/60hz with European transformer;
- Each pump is shipped with a Kit Assembly, delayed fuse, level probe with axial foot filter (PVDF), 5 bar injection valve (PVDF), PVDF delivery hose (length 2 m), PVC suction hose (length 2 m), discharge hose (length 2 m), input signal cable (length 2,5 m);
- Conform with CE safety Directives;
- D.M. n.174 dated 06/04/2004 compliant about materials suitable for contact with water for human consumption.



REF.	FLOW RATE	PUMP HEAD	O-RING	
DG300	2 l/h at 18 bar	PVDF	VITON	
DG300A (*)	2 l/h at 18 bar	PP	EPDM	
DG304	8 l/h at 8 bar	PVDF	VITON	
DG304A (*)	8 l/h at 8 bar	PP	EPDM	

(*) suitable for alkaline liquid chemicals;
not available in stock – Delivery 3 weeks.

PL Series Metering Pumps Horizontal Mounting

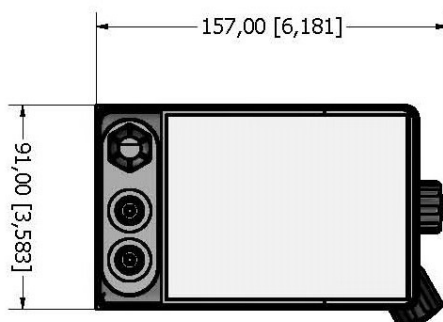
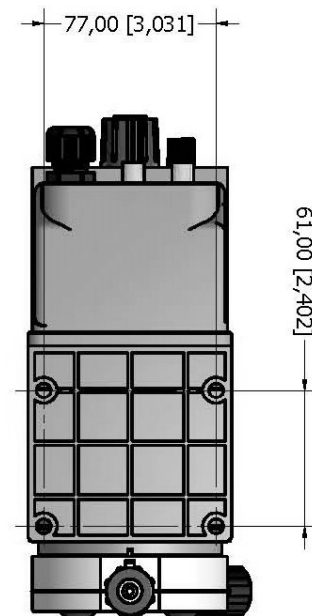
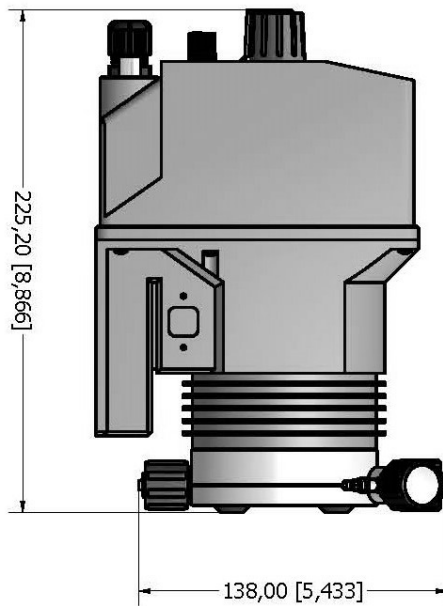
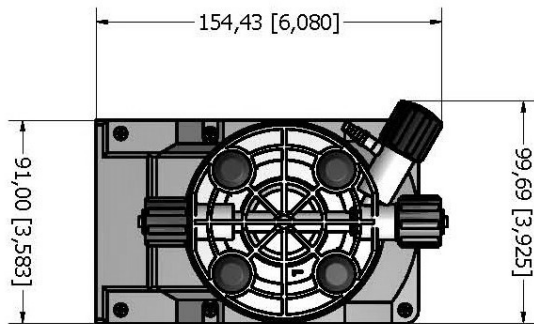

Dimensions are in mm [inches]

MF Series Metering Pumps Horizontal Mounting



- MF series metering digital pumps horizontal mounting;
- Microprocessor technology (Constant, Divide, Multiply, PPM, Batch, Volt, mA, %, MLQ), stand-by and flow sensor input, alarm output and level control. Recovery fault mode, work-pause mode and upkeep mode (from 1 pulse/minute at 180 pulses/minute);
- Body pump's in PVDF (and o-rings in VITON) or PP (and o-rings in EPDM), with manual venting;
- Black enclosure in PP material;
- Protection class IP65;
- Audible noise 73,4 dB(A);
- Environment temperature 10 ÷ 45 °C;
- Chemical temperature 0 ÷ 50 °C;
- Power supply 230Vac 50/60hz with European transformer;
- Each pump is shipped with a Kit Assembly, delayed fuse, level probe with axial foot filter (PVDF), 5 bar injection valve (PVDF), PVDF delivery hose (length 2 m), PVC suction hose (length 2 m), discharge hose (length 2 m), input signal cable (length 2,5 m);
- Conform with CE safety Directives;
- D.M. n.174 dated 06/04/2004 compliant about materials suitable for contact with water for human consumption.

REF.	FLOW RATE	PUMP HEAD	O-RING	
DG310	2 l/h at 18 bar	PVDF	VITON	
DG310A (*)	2 l/h at 18 bar	PP	EPDM	
DG314	8 l/h at 8 bar	PVDF	VITON	
DG314A (*)	8 l/h at 8 bar	PP	EPDM	

(*) suitable for alkaline liquid chemicals;
not available in stock – Delivery 3 weeks.

MF Series Metering Pumps Horizontal Mounting

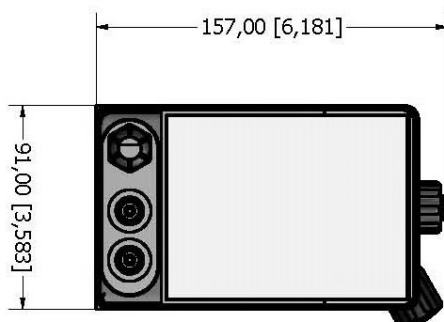
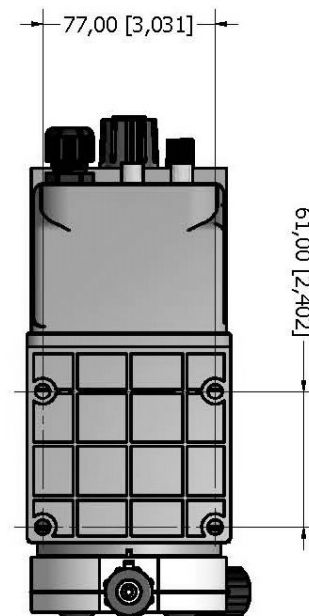
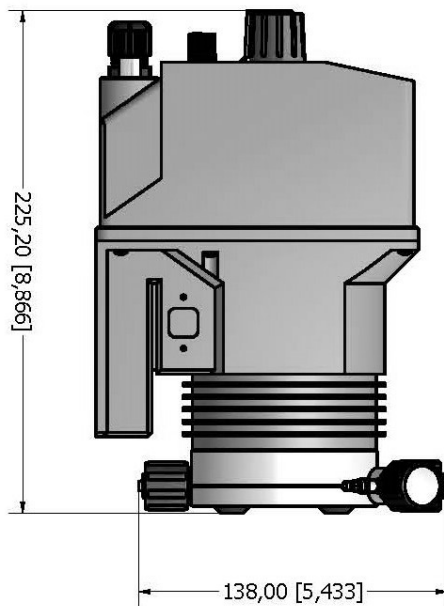
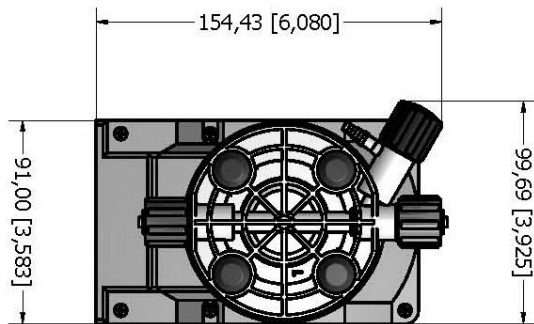

Dimensions are in mm [inches]



MF Series Metering Pumps Vertical Mounting



- MF series metering digital pumps vertical mounting;
- Microprocessor technology (Constant, Divide, Multiply, PPM, Batch, Volt, mA, %, ml/q), with level control. Recovery fault mode, work-pause mode and upkeep mode (from 1 pulse/hour at 180 pulses/minute);
- Body pump's in PVDF (and o-rings in VITON) or PP (and o-rings in EPDM), with manual venting;
- Black enclosure in PP material;
- Protection class IP65;
- Audible noise 70,4 dB(A);
- Environment temperature 10 ÷ 45°C;
- Chemical temperature 0 ÷ 50°C;
- Power supply 230Vac 50/60hz with European transformer;
- Each pump is shipped with a Kit Assembly, delayed fuse, level probe with axial foot filter (PVDF), 5 bar injection valve (PVDF), PVDF delivery hose (length 2 m), PVC suction hose (length 2 m), discharge hose (length 2 m), input signal cable (length 2,5 m);
- Conform with CE safety Directives;
- D.M. n.174 dated 06/04/2004 compliant about materials suitable for contact with water for human consumption.



REF.	FLOW RATE	PUMP HEAD	O-RING	
DG320	2 l/h at 15 bar	PVDF	VITON	
DG320A (*)	2 l/h at 15 bar	PP	EPDM	
DG324	6 l/h at 7 bar	PVDF	VITON	
DG324A (*)	6 l/h at 7 bar	PP	EPDM	

(*) suitable for alkaline liquid chemicals;
not available in stock – Delivery 3 weeks.

MF Series Metering Pumps Vertical Mounting



DIMENSIONI		
	<i>mm</i>	<i>inches</i>
<i>A</i>	106.96	4.21
<i>B</i>	210.44	8.28
<i>C</i>	199.44	7.85
<i>D</i>	114.50	4.50
<i>E</i>	187.96	7.40
<i>F</i>	97.00	3.81
<i>G</i>	106.96	4.21
<i>H</i>	125.47	4.93
<i>L</i>	50.00	1.96
<i>M</i>	201.00	7.91

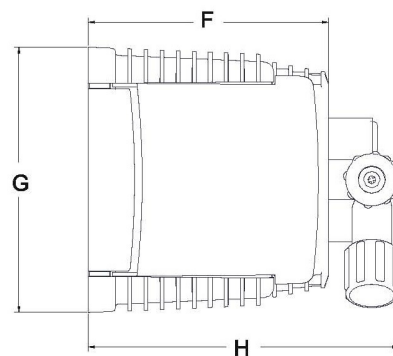
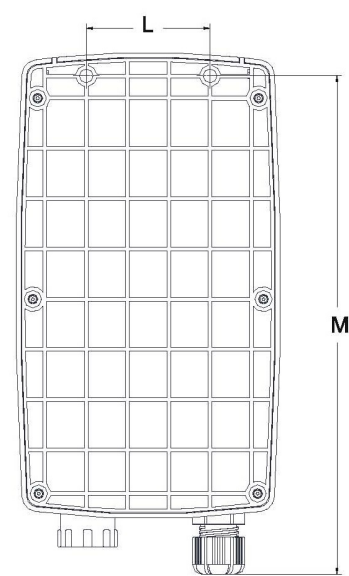
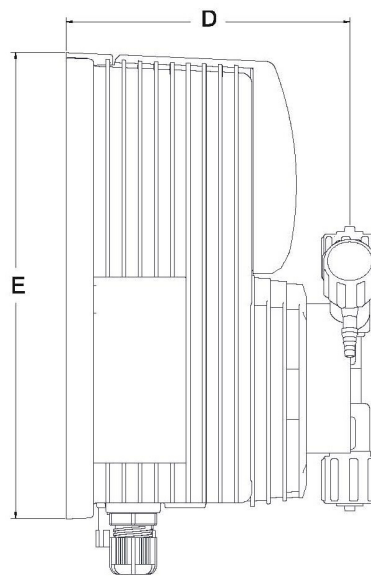
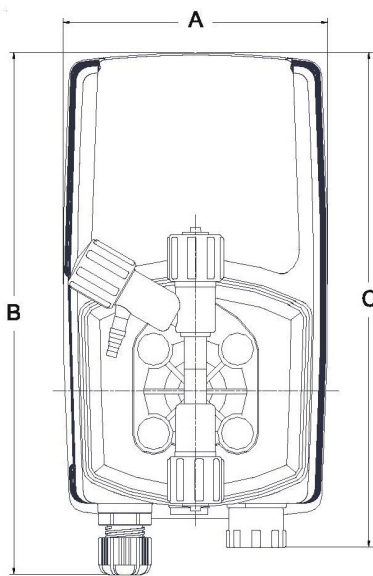

CL Series Metering Pumps Vertical Mounting



- CL series metering pumps vertical mounting;
- Microprocessor technology; pompa costante con controllo di livello e regolazione della portata e con divisore 0-10% (da 1 impulso/minuto a 180 impulsi/minuto);
- Body pump's in PVDF (and o-rings in VITON) or PP (and o-rings in EPDM), with manual venting;
- Black enclosure in PP material;
- Protection class IP65;
- Audible noise 74 dB(A);
- Environment temperature 10 ÷ 45°C;
- Chemical temperature 0 ÷ 50°C;
- Power supply 230Vac 50/60hz with European transformer;
- Each pump is shipped with a Kit Assembly, delayed fuse, level probe with axial foot filter (PVDF), 5 bar injection valve (PVDF), PVDF delivery hose (length 2 m), PVC suction hose (length 2 m), discharge hose (length 2 m), input signal cable (length 2,5 m);
- Conform with CE safety Directives;
- D.M. n.174 dated 06/04/2004 compliant about materials suitable for contact with water for human consumption.



REF.	FLOW RATE	PUMP HEAD	O-RING	
DG330	2 l/h at 15 bar	PVDF	VITON	
DG330A (*)	2 l/h at 15 bar	PP	EPDM	
DG334	6 l/h at 7 bar	PVDF	VITON	
DG334A (*)	6 l/h at 7 bar	PP	EPDM	

(*) suitable for alkaline liquid chemicals;
not available in stock – Delivery 3 weeks.

CL Series Metering Pumps Vertical Mounting



DIMENSIONI		
	<i>mm</i>	<i>inches</i>
<i>A</i>	106.96	4.21
<i>B</i>	210.44	8.28
<i>C</i>	199.44	7.85
<i>D</i>	114.50	4.50
<i>E</i>	187.96	7.40
<i>F</i>	97.00	3.81
<i>G</i>	106.96	4.21
<i>H</i>	125.47	4.93
<i>L</i>	50.00	1.96
<i>M</i>	201.00	7.91

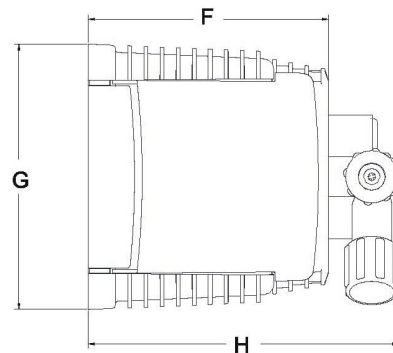
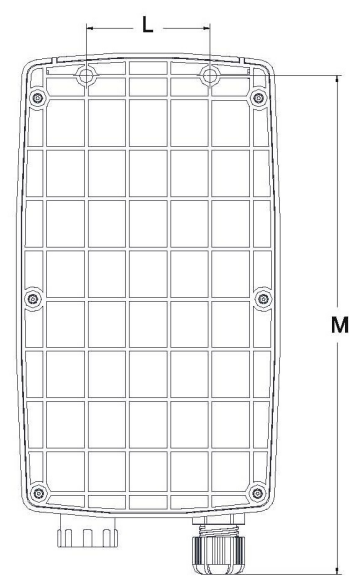
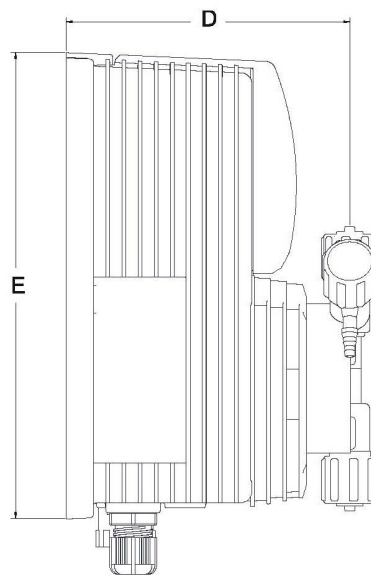
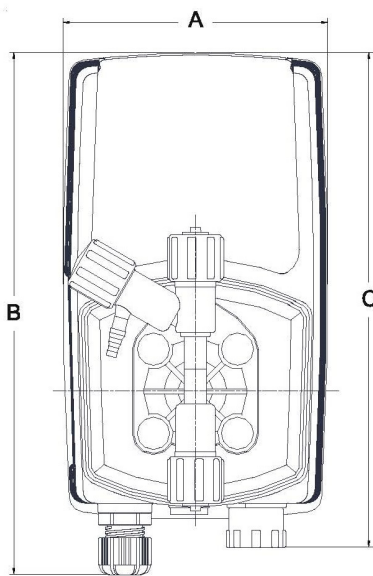



SPARE PARTS

REF.	DESCRIPTION	
DG452	5 m delivery hose in PVDF 6x4	
DG453	100 m hose in PVC 6x4	
DG454	100 m hose in PE 6x4	
DG460	Kit Assembly for pumps horizontal mounting, o-ring in VITON	
DG461	Kit Assembly for pumps horizontal mounting, o-ring in EPDM	
DG462	Kit Assembly for pumps vertical mounting, o-ring in VITON	
DG463	Kit Assembly for pumps vertical mounting, o-ring in EPDM	



STATIC MIXERS

- PVC-U static mixer filled with PP mixing elements;
- With injection valve 1/2" - 4x6 0,3 bar.



REF.	INSPECTIONABLE	FITTING	
DG470	YES	1 ¼"	
DG471	NOT	D40	
DG472	YES	1 ½"	
DG473	YES	2"	

ACCESSORIE

REF.	DESCRIPTION	
DG450	Fixing bracket for vertical pumps	



TURBINE PULSE EMITTER WATER METER

- Threaded pulse emitter water meter for cold and hot water, single (mod. 15 - 20 - 25 - 30 - 40) and multiple (mod. 50) jet counter with wet or dry dial;
- Thread sizes range: from ½" to 2";
- Brass case and head (except for 50 mm 2" model with cast iron case and head);
- Range temperature = 4 ÷ 30 °C;
- Max operating pressure = 16 bar;
- Constant K = 4 pulses/liter;
- 2m cable length (RG58), equipped with BNC connector;
- Reed contact with 10⁹ closing operations;
- Max voltage 250 VAC, 200 VDC;
- Max current 1 A;
- Max power 10 VA.

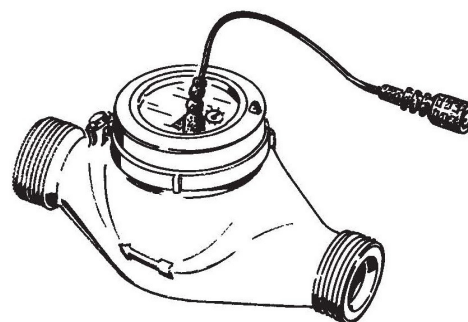

REF.	GAUGE (mm)	GAUGE (inches)	WITH DIAL ...	
DG480	15	½	WET	
DG481	20	¾	WET	
DG482	25	1	WET	
DG483	30	1 ¼	WET	
DG484	40	1 ½	WET	
DG485	50	2	WET	
DG490 (*)	15	½	DRY	
DG491 (*)	20	¾	DRY	
DG492 (*)	25	1	DRY	
DG493 (*)	30	1 ¼	DRY	
DG494 (*)	40	1 ½	DRY	
DG495 (*)	50	2	DRY	

(*) not available in stock – Delivery 3 weeks.



TURBINE PULSE EMITTER WATER METER

DIMENSIONS

Gauge	mm inch	15 1/2	20 3/4	25 1	30 1.1/4	40 1.1/2	50 2
Length without hose fittings	A mm	110	130	160	160	200	300
Length with hose fittings	B mm	190	228	260	280	340	460
Width	C mm	80	80	100	100	110	108
Height	D mm	110	110	132	132	137	130,5
Height from hose	E mm	24	24	34	34	42	50,5
Weight with hose fitting	Kg	0,850	1,100	1,750	2,000	3,460	-
CEE approval number		B93 320 01	B93 320 02	B97 320 03	B97 320 04	B99 320 11	B02 320 13

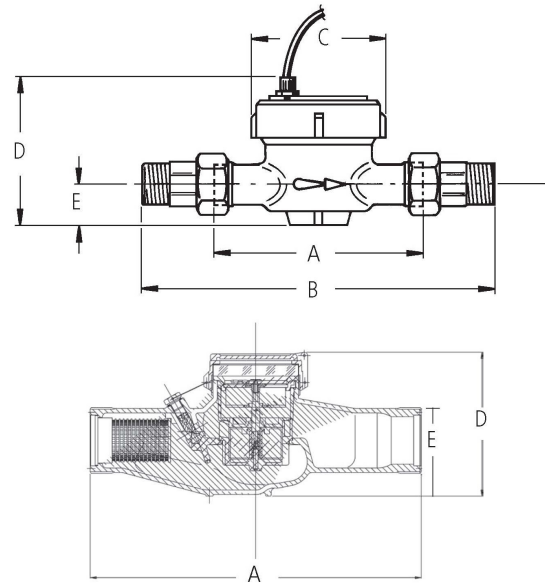

FEATURES

Gauge	mm inch	15 1/2	20 3/4	25 1	30 1.1/4	40 1.1/2	50 2
Inertial breaking	l/h	10	15	20	20	25	50
Max temporary flow delivery	m ³ /h	3	5	7	10	20	30
Flow delivery with 10m of load loss	m ³ /h	3	5	7	10	20	30
Nominal flow rate	m ³ /h	1.5	2.5	3.5	5	10	15
First precision delivery ±5%	l/h	30	50	70	100	200	450
Second precision delivery ±2%	l/h	120	200	280	400	800	3000
Max operation pressure	bar	16	16	16	16	16	16
Minimum reading	l	0.1	0.1	0.1	0.1	0.1	0.5
Maximum reading	m ³	10 ⁵	10 ⁵	10 ⁵	10 ⁵	10 ⁵	10 ⁶
Turbine revs per liter	g/l	34.8	22.5	11.7	11.7	4.5	3.16

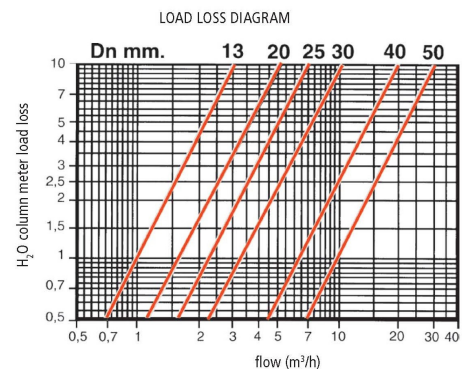
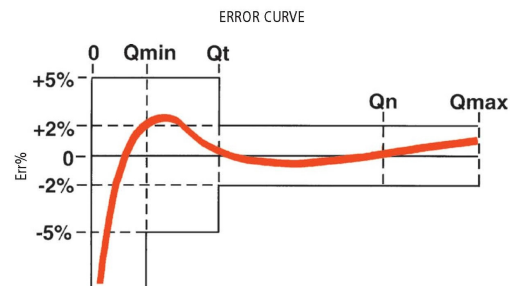



- Suitable to be assembled with dosing pumps on catalogue;
- Each dosing system consisting in:
 - nr.1 tank in polyethylene (HDPE) for chemical mixing;
 - nr.1 suction lances with o-ring in VITON (optional in EPDM);
 - nr.1 manual stirrer;
- All dosing station components assembled on are enclosed into tank diameter;
- Stirrers screwed on thread metal insert are tilted for better central mixing;
- Stainless Steel (AISI 316) fixing screws with rubber cap;
- With level indicator;
- Tanks can be assembled with:
 - nr.1 metering pump (not included in the dosing system);
 - nr.1 manual stirrer;
 - nr.1 feed water valve;
 - nr.1 outgassing pump hose;
 - nr.1 outgassing valve (on the higher top side);
 - nr.1 bleed water valve (on the lower side);
 - nr.1 suction lance;
- Range temperature = 4 ÷ 40°C;
- On demand are available safety bunds.



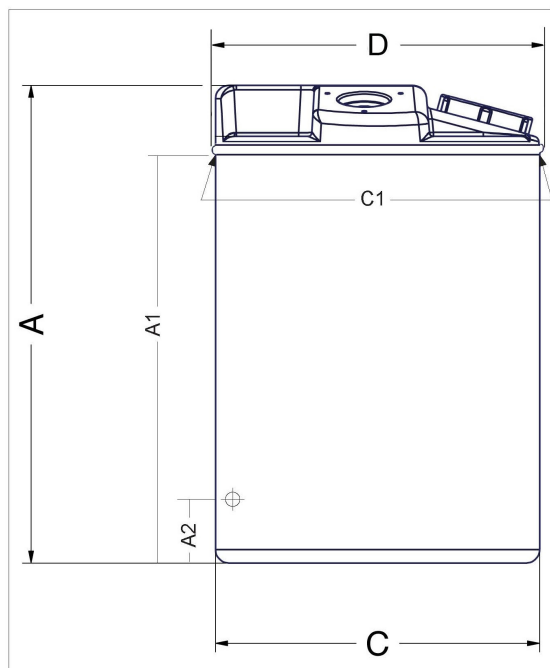

REF.	VOLUME (liters)	O-RING MATERIAL	A (mm)	A1 - FEED WATER VALVE HEIGHT (mm)	C (mm)	C1 (mm)	D (mm)	FEED WATER (mm)
DG400	50	VITON	505	425	420	-	-	95
DG400A (*)	50	EPDM	505	425	420	-	-	95
DG402	120	VITON	650	475	485	-	-	650
DG402A (*)	120	EPDM	650	475	485	495	120	650
DG404	250	VITON	850	780	610	-	-	120
DG404A (*)	250	EPDM	850	780	610	-	-	120

(*) not available in stock – Delivery 3 weeks.



SUCTION LANCES FOR DOSING SYSTEMS

- For pumps up to 10 l/h;
- Level switch;
- Foot valve and foot filter;
- Adjustable height;
- 1 1/2" pipe fitting;
- Lateral output (1/2" fitting);
- PVC body.

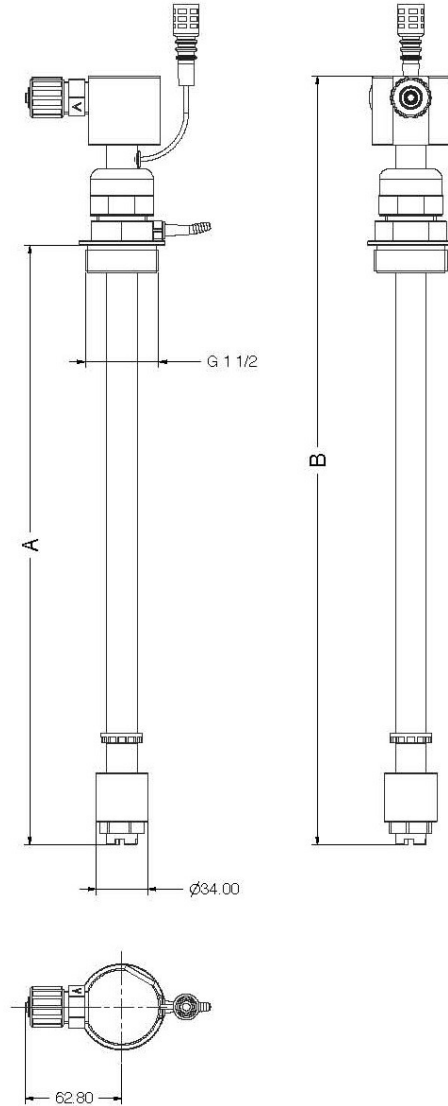
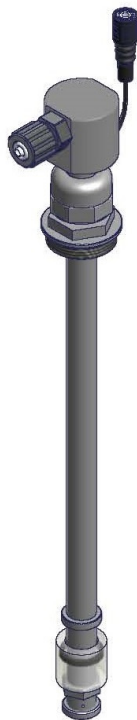

(*) suitable for alkaline liquid chemicals;
not available in stock – Delivery 3 weeks.

REF.	DOSING SYSTEM	O-RING MATERIAL	A (mm)	B (mm)	
DG430	DG400 – DG402	VITON	630	740	
DG430A (*)	DG400A – DG402A	EPDM	630	740	
DG434	DG404	VITON	1080	1190	
DG434A (*)	DG404A	EPDM	1080	1190	



MANUAL STIRRER FOR DOSING SYSTEM

- PVC-U shaft;
- 2-blade impeller;
- Impeller diameter = 130 mm
- Holes diameter = 8,5 mm.

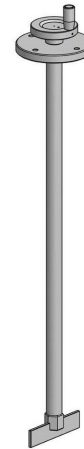

REF.	DOSING SYSTEM	A (mm)	Ø B (mm)	D (mm)	HOLES NUMBER AND POSITION
DG440	DG400 DG400A	100	120	450	4 at 90°
DG442	DG402 DG402A	125	145	650	3 at 120°
DG444	DG404 DG404A	125	145	770	3 at 120°

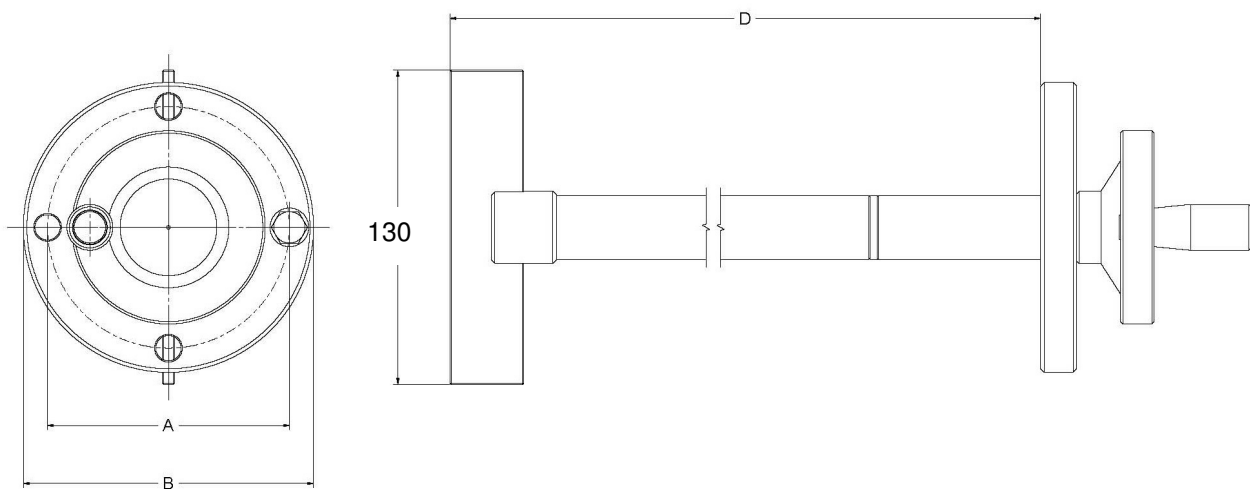



SAFETY BUNDS

- Material in polyethylene (HDPE), with reinforced collar for increasing security;
- Range temperature = 4 ÷ 40 °C.

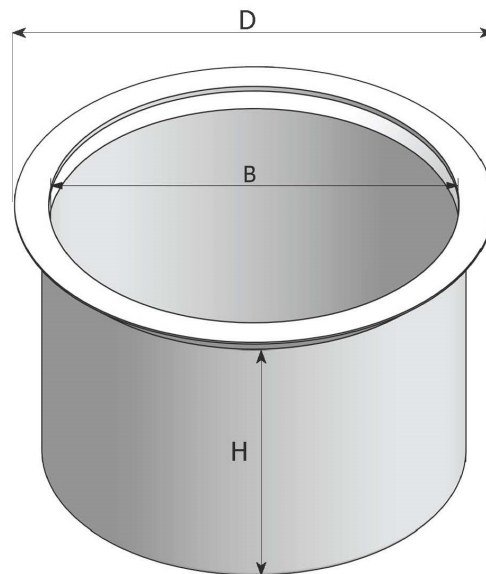

REF.	MODEL	VOLUME (liters)	B (mm)	D (mm)	H (mm)	
DG410 (*)	50	60	430	510	425	
DG412 (*)	120	120	520	545	615	
DG414 (*)	250	300	660	695	875	

(*) not available in stock – Delivery 3 weeks.



UV sterilizers and spare parts



Residential U.V. Sterilizers Inox



- monolamp U.V. sterilizer of close construction in AISI 304 polished material for point-of-use treatment devices;
- conform with CE safety Directives;
- D.M. n.174 dated 06/04/2004 compliant about materials suitable for contact with water for human consumption;
- complete with n.2 diameter 2" fixing clips and with n.2 JACO 1/4" elbows;
- power box with electronic circuit, cable and plug;
- failure led and alarm system;
- lamp quartz sheath;
- max operating pressure 7 bar;
- temperature 2 ÷ 40°C;
- power supply 230 V – 50 Hz;
- irradiation > 30 mJ/cm²;
- lamp life 8.000 hours;
- protection class IP42;
- for relative spare parts see 07-02-01-EN data sheet.

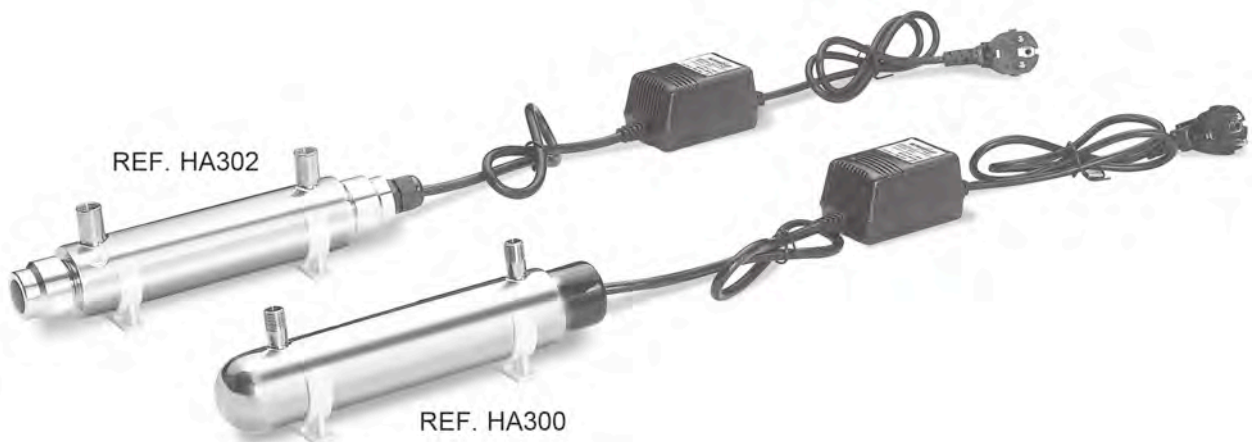

REF.	MODEL	MAX FLOW (l/h)	LAMPS NUMBER	POWER (W)	CONNECTIONS	DIAMETER (mm)	LENGTH (mm)	
HA300	HR-60	240	1	10	1/4" BSP M	50,8	260	
HA302	PC-1	240	1	10	1/4" BSP M	50,8	268	

Residential U.V. Sterilizers W Series



- to be used for residential water disinfection systems;
- monolamp U.V. sterilizer of close construction in AISI 304 polished material;
- power box with electronic circuit, cable and plug;
- failure led and alarm system;
- conform with CE safety Directives;
- D.M. n.174 dated 06/04/2004 compliant about materials suitable for contact with water for human consumption;
- lamp quartz sheath;
- max operating pressure 7 bar;
- temperature 2 ÷ 40°C;
- power supply 230 V – 50 Hz;
- irradiation > 30 mJ/cm²;
- lamp life 10.000 hours;
- protection class IP42;
- for relative spare parts see 07-02-01-EN data sheet.



REF.	MODEL	MAX FLOW (l/h)	LAMPS NUMBER	POWER (W)	CONNECTIONS	DIAMETER (mm)	LENGTH (mm)	
HA310	W-180	680	1	15	½" BSP M	63,5	364	
HA315	W-360	1360	1	21	½" BSP M	63,5	544	
HA320	W-480	1810	1	29	½" BSP M	63,5	694	
HA325	W-720	2720	1	40	¾" BSP M	63,5	924	

Industrial U.V. Sterilizers FC Series



- to be used for commercial and industrial water disinfection systems;
- monolamp U.V. sterilizer with polished AISI 304 sterilizing chamber (option in AISI 316L not available in stock) with inspection window and drain connection;
- electric box with electronic circuit, connection cable, operating time meter and switch;
- operating and failure led, with alarm system (excepted models FC-35 and FC-45);
- conform with CE safety Directives;
- D.M. n.174 dated 06/04/2004 compliant about materials suitable for contact with water for human consumption;
- lamp quartz sheath;
- max operating pressure 7 bar, temperature $2 \div 40^{\circ}\text{C}$;
- power supply 230 V – 50 Hz, irradiation $> 30 \text{ mJ/cm}^2$, lamp life 10.000 hours;
- protection class IP43;
- possibility of connection with shut down solenoid valve (only for models FC-35 and FC-45);
- for relative spare parts see 07-02-01-EN data sheet.

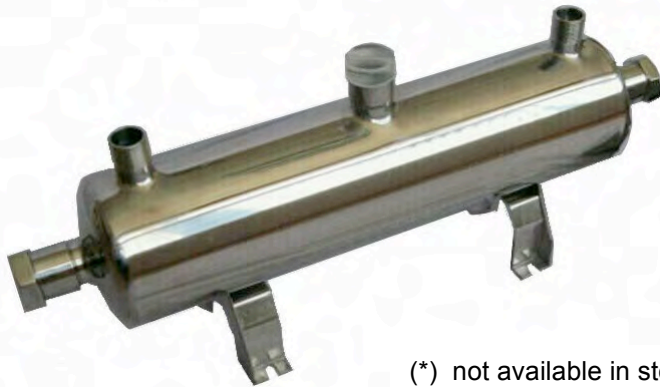

(*) not available in stock.

REF.	MOD.	AISI	MAX FLOW (l/h)	POWER (W)	CONNECTIONS	DIAMETER (mm)	LENGHT (mm)	
HA350	FC-8	304	1.810	29	¾" BSP M	114	710	
HA350A (*)	FC-8	316L	1.810	29	¾" BSP M	114	710	
HA355	FC-12	304	2.720	40	1" BSP M	133	940	
HA355A (*)	FC-12	316L	2.720	40	1" BSP M	133	940	
HA360	FC-15	304	3.400	65	1" BSP M	133	940	
HA360A (*)	FC-15	316L	3.400	65	1" BSP M	133	940	
HA365	FC-20	304	4.536	65	1 ½" BSP M	160	940	
HA365A (*)	FC-20	316L	4.536	65	1 ½" BSP M	160	940	
HA370	FC-24	304	5.443	80	1 ½" BSP M	160	940	
HA370A (*)	FC-24	316L	5.443	80	1 ½" BSP M	160	940	
HA375	FC-35	304	7.938	100	2" BSP M	160	1.235	
HA375A (*)	FC-35	316L	7.938	100	2" BSP M	160	1.235	
HA380	FC-45	304	10.200	120	2" BSP M	160	1.235	
HA380A (*)	FC-45	316L	10.200	120	2" BSP M	160	1.235	

Industrial Flanged Multilamp U.V. Sterilizers FC-D Series



- to be used for industrial water disinfection systems;
- multilamp U.V. sterilizer with polished AISI 304 sterilizing chamber (option in AISI 316L not available in stock) with inspection window and drain connection;
- electric box with electronic circuit, connection cable, operating time meter and switch;
- operating and service/failure led;
- conform with CE safety Directives;
- D.M. n.174 dated 06/04/2004 compliant about materials suitable for contact with water for human consumption;
- lamp quartz sheath;
- max operating pressure 7 bar;
- temperature $2 \div 40^{\circ}\text{C}$;
- power supply 230 V – 50 Hz;
- irradiation $> 30 \text{ mJ}/\text{cm}^2$;
- lamp life 10.000 hours;
- protection class IP43;
- possibility of connection with shut down solenoid valve;
- for relative spare parts see 07-02-01-EN data sheet.



(*) not available in stock.

REF.	MODEL	AISI	MAX FLOW (l/h)	LAMP NUMBER	POWER (W)	CONNECTIONS	DIAMETER (mm)	LENGTH (mm)	
HA400	FC-70D	304	15.900	2	200	DN50 FLANGED	220	1.250	
HA400A (*)	FC-70D	316L	15.900	2	200	DN50 FLANGED	220	1.250	
HA410	FC-120D	304	27.250	3	360	DN65 FLANGED	273	1.250	
HA410A (*)	FC-120D	316L	27.250	3	360	DN65 FLANGED	273	1.250	
HA420	FC-180D	304	40.880	5	600	DN80 FLANGED	323	1.250	
HA420A (*)	FC-180D	316L	40.880	5	600	DN80 FLANGED	323	1.250	
HA430	FC-250D	304	56.780	7	840	DN100 FLANGED	400	1.250	
HA430A (*)	FC-250D	316L	56.780	7	840	DN100 FLANGED	400	1.250	

U.V. Sterilizers HR - PC - W - FC - FC/D Spare Parts



REF.	DESCRIPTION	STERILIZERS UV		
HA500	LAMP UV - T5L10 W - D.18 x L.219 mm	HR-60	PC-1	
HA502	LAMP UV - T5L15 W - D.18 x L.310 mm	W-180		
HA504	LAMP UV - T5L21 W - D.18 x L.444 mm	W-360		
HA506	LAMP UV - T5L29 W - D.18 x L.630 mm	W-480	FC-8	
HA508	LAMP UV - T5L40 W - D.18 x L.850 mm	W-720	FC-12	
HA510	LAMP UV - T5L65 W - D.18 x L.850 mm	FC-15	FC-20	
HA512	LAMP UV - T6L80 W - D.23 x L.850 mm	FC-24		
HA514	LAMP UV - T6L100 W - D.23 x L.1160 mm	FC-35	2x FC-70D	
HA516	LAMP UV - T6L120 W - D.18 x L.1150 mm	FC-45	3x FC-120D 5x FC-180D 7x FC-250D	
HA530	LAMP UV - T5L10 W QUARTZ SHEATH D.24,5 x L.250 mm ONE OPEN END	HR-60		
HA531	LAMP UV - T5L10 W QUARTZ SHEATH D.24,5 x L.250 mm	PC-1		
HA532	LAMP UV - T5L15 W QUARTZ SHEATH D.24,5 x L.350 mm	W-180		
HA534	LAMP UV - T5L21 W QUARTZ SHEATH D.24,5 x L.530 mm	W-360		
HA536	LAMP UV - T5L29 W QUARTZ SHEATH D.24,5 x L.680 mm	W-480	FC-8	
HA538	LAMP UV - T5L40-65 W QUARTZ SHEATH D.24,5 x L.910 mm	W-720	FC-12 FC-15	
HA540	LAMP UV - T5L65W - T6L80W QUARTZ SHEATH D.30,0 x L.910 mm	FC-20	FC-24	
HA542	LAMP UV - T6L100-120 W QUARTZ SHEATH D.30,0 x L.1205 mm	FC-35	FC-45	2x FC-70D
		3x FC-120D	5x FC-180D	7x FC-250D

U.V. Sterilizers HR - PC - W - FC - FC/D Spare Parts



REF.	DESCRIPTION	STERILIZERS UV			
HA550 (*)	QUARTZ O-RING SILICONE FOR TUBE D.24,5 mm	HR-60 W-180	PC-1 W-360	W-480	W-720
HA550A (**)	QUARTZ O-RING VITON FOR TUBE D.24,5 mm	FC-8	FC-12	FC-15	
HA552 (***)	QUARTZ O-RING SILICONE FOR TUBE D.30,0 mm	FC-20 FC-70D	FC-24 FC-120D	FC-35 FC-180D	FC-45 FC-250D
HA552A (****)	QUARTZ O-RING VITON FOR TUBE D.30,0 mm	FC-20 FC-70D	FC-24 FC-120D	FC-35 FC-180D	FC-45 FC-250D
HA560	ELECTRONIC BALLAST UV-3 230V/50Hz FOR LAMP 10 - 16 W	HR-60	PC-1	W-180	
HA562	ELECTRONIC BALLAST UV-6 90-264V/50-60Hz FOR LAMP 20 - 40 W	W-360	W-480	W-720	
HA563	INSIDE ELECTRONIC BALLAST UV-6 90-264V/50-60Hz FOR LAMP 20 - 40 W	FC-8	FC-12		
HA564	INSIDE ELECTRONIC BALLAST UV-8 90-264V/50-60Hz FOR LAMP 65 - 80 W	FC-15	FC-20	FC-24	
HA566	INSIDE ELECTRONIC BALLAST UV-12 100-240V/50Hz 100 - 120 W SINGLE-LAMP	FC-35 FC-70D	FC-45 FC-120D	FC-180D	FC-250D
HA570	ELECTRICAL PANEL COMPLETE	FC-8	FC-12		
HA572	ELECTRICAL PANEL COMPLETE	FC-15	FC-20	FC-24	
HA574	ELECTRICAL PANEL COMPLETE	FC-35	FC-45		
HA576	ELECTRICAL PANEL COMPLETE	FC-70D			
HA577	ELECTRICAL PANEL COMPLETE	FC-120D			
HA578	ELECTRICAL PANEL COMPLETE	FC-180D			
HA579	ELECTRICAL PANEL COMPLETE	FC-250D			

(*) This o-ring is contained (2 for each lamp) in all models FC-8 to FC-15, in batches before September 2015: for the next batches it is an optional.

(**) This o-ring is contained (2 for each lamp) in all models FC-8 to FC-15, in batches starting in September 2015.

(***) This o-ring is contained (2 for each lamp) in batches before September 2015: for the next batches it is an optional.

(****) This o-ring is contained (2 for each lamp) in all models FC-20 to FC-250D, in batches starting in September 2015.

Old U.V. Sterilizers Spare Parts



REF.	DESCRIPTION	
HA055	Plastic Lamp UV 6 W D.16,0 x L.210 mm	
HA049	Lamp UV 6 W Inox 2+2 pin D.16,0 x L.225 mm	
HA050	Lamp 10 W D.18,0 x L.210 mm	
HA051	Lamp 12 W D.18,0 x L.248 mm	
HA052	Lamp 16 W D.18,0 x L.330 mm	
HA053	Lamp 30 W D.18,0 x L.450 mm	
HA508 (*)	Lamp 40 W D.18,0 x L.850 mm	
HA056	Lamp 80 W D.18,0 x L.850 mm	
HA065	Quartz for plastic lamp 6 W UV D.22,0 x L.249 mm	
HA067	Quartz for lamp 6 W UV Inox D.22,0 x L.251 mm	
HA060	Quartz for lamp 10 W D.22,0 x L.204 mm	
HA061	Quartz for lamp 12 W D.22,0 x L.238 mm	
HA062	Quartz for lamp 16 W D.22,0 x L.370 mm	
HA063	Quartz for lamp 30 W D.22,0 x L.500 mm	
HA064	Quartz for lamp 40 W and 80 W D.22,0 x L.900 mm	
HA074	Quartz o-ring silicone D.22,0 mm	
HA058	Electronic Ballast UV 6 W Inox	
HA069	Electronic Ballast UV 6 W plastic	
HA070	Transformer UV 12-16	
HA073	Power electrical board UV 30-40-240-340	
HA073A	Power electrical board UV 440-540	

(*) Please, ask to our Technical Department in order to verify the suitability with the old Models.



Filter housings,
cartridges
and polyphosphate
feeders



PP String Wound Filtering Cartridges



- string wound filtering cartridges with core;
- string and core in polypropylene;
- double/triple retention capacity than a compact structure cartridge;
- dimensions external diameter 60 mm, internal diameter 28 mm;
- length 9 7/8" or 20";
- suggested filtering flow rate for 10" length: 18÷24 lpm;
- max filtering flow rate for 40" length : 60 lpm;
- max ΔP recommended 1 bar;
- max operating temperature = 60°C.



REF.	MODEL	LENGTH (inch)	MICRON	
FC100	DLSW-10-01 (9 7/8")	9 7/8"	1	
FC101	DLSW-10-05 (9 7/8")	9 7/8"	5	
FC102	DLSW-10-10 (9 7/8")	9 7/8"	10	
FC103	DLSW-10-20 (9 7/8")	9 7/8"	20	
FC104	DLSW-10-50 (9 7/8")	9 7/8"	50	
FC105	DLSW-10-100 (9 7/8")	9 7/8"	100	
FC110	DLSW-20-01	20"	1	
FC111	DLSW-20-05	20"	5	
FC112	DLSW-20-10	20"	10	
FC113	DLSW-20-20	20"	20	
FC114	DLSW-20-50	20"	50	
FC115	DLSW-20-100	20"	100	

PP String Wound Filtering Cartridges



Flow rate – pressure drop diagram (Per single 10-inch equivalent)

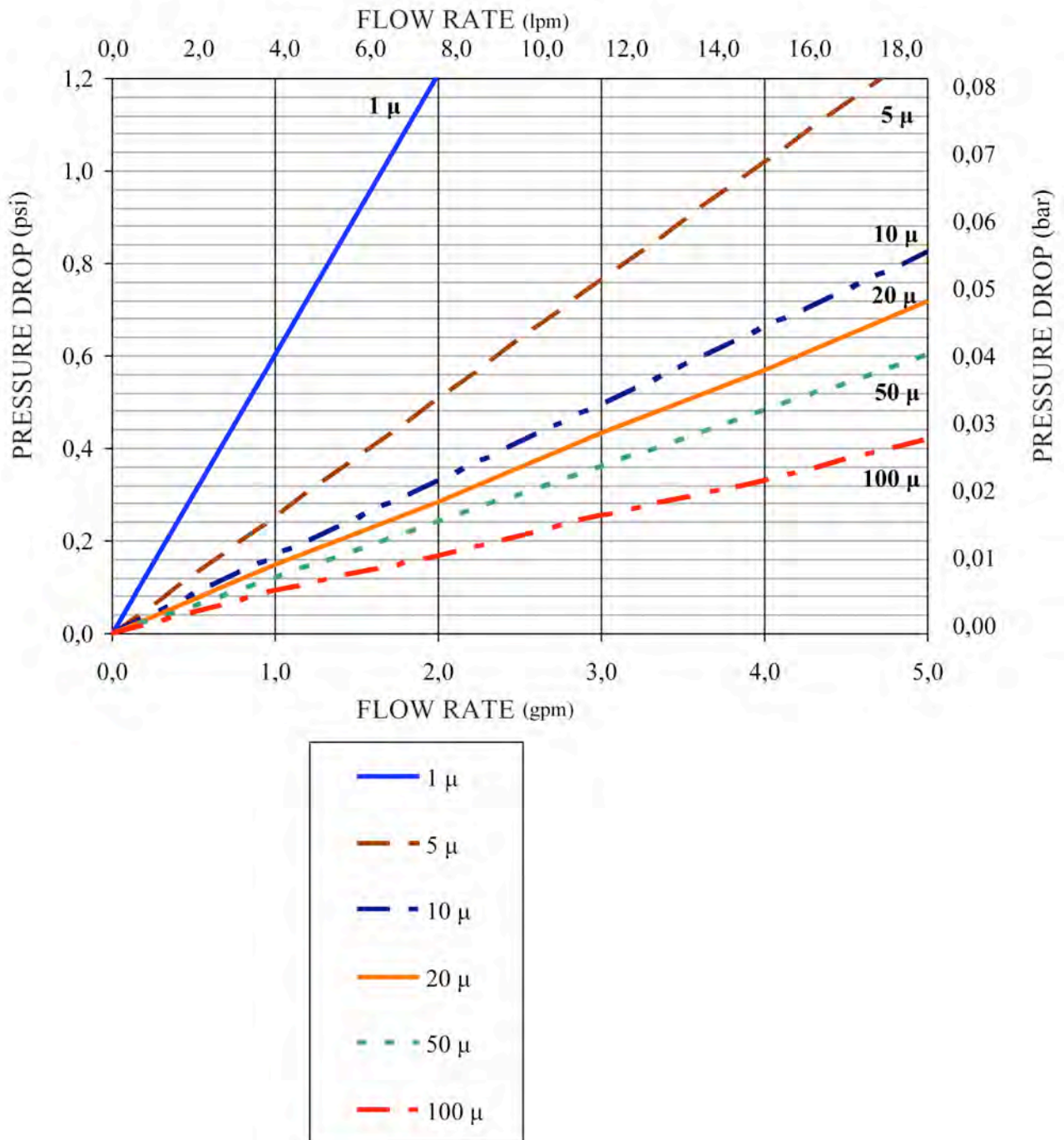

Melt Blown Filtering Cartridges



- thermowelded polypropylene fibers cartridges with no lubricants or antistatic additives;
- any migration into the filtered water;
- wide chemical compatibility;
- high retention capacity & filtration efficiency multilayer structure;
- filtration efficiency 96 % minimum;
- high retention capacity extends cartridge life;
- external diameter 63 mm, internal 28 mm;
- length: 9 7/8" – 20" – 30" – 40".
- suggested filtration flow rate for 10" length: 15 ÷ 20 lpm;
- max filtration flow rate for 40" length: 60 lpm;
- max ΔP recommended 1,4 bar;
- max operating temperature = 80°C.

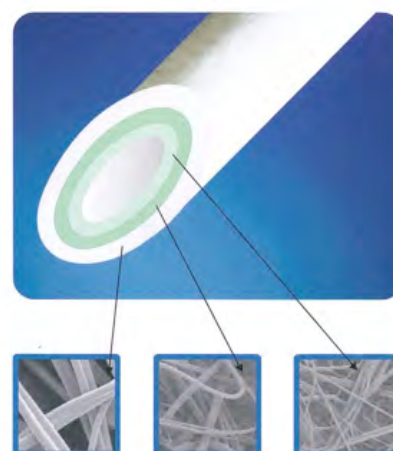

REF.	MODEL	LENGTH (inch)	MICRON	
FC050	DLPP-01-10	9 7/8"	1	
FC051	DLPP-05-10	9 7/8"	5	
FC052	DLPP-10-10	9 7/8"	10	
FC053	DLPP-20-10	9 7/8"	20	
FC054	DLPP-30-10	9 7/8"	30	
FC055	DLPP-50-10	9 7/8"	50	
FC060	DLPP-01-20	20"	1	
FC061	DLPP-05-20	20"	5	
FC062	DLPP-10-20	20"	10	
FC063	DLPP-20-20	20"	20	
FC064	DLPP-30-20	20"	30	
FC065	DLPP-50-20	20"	50	
FC070	DLPP-01-30	30"	1	
FC071	DLPP-05-30	30"	5	
FC072	DLPP-10-30	30"	10	
FC073	DLPP-20-30	30"	20	
FC074	DLPP-30-30	30"	30	
FC075	DLPP-50-30	30"	50	
FC080	DLPP-01-40	40"	1	
FC081	DLPP-05-40	40"	5	
FC082	DLPP-10-40	40"	10	
FC083	DLPP-20-40	40"	20	
FC084	DLPP-30-40	40"	30	
FC085	DLPP-50-40	40"	50	

Melt Blown Filtering Cartridges



Flow rate – pressure drop diagram (Per single 10-inch equivalent)

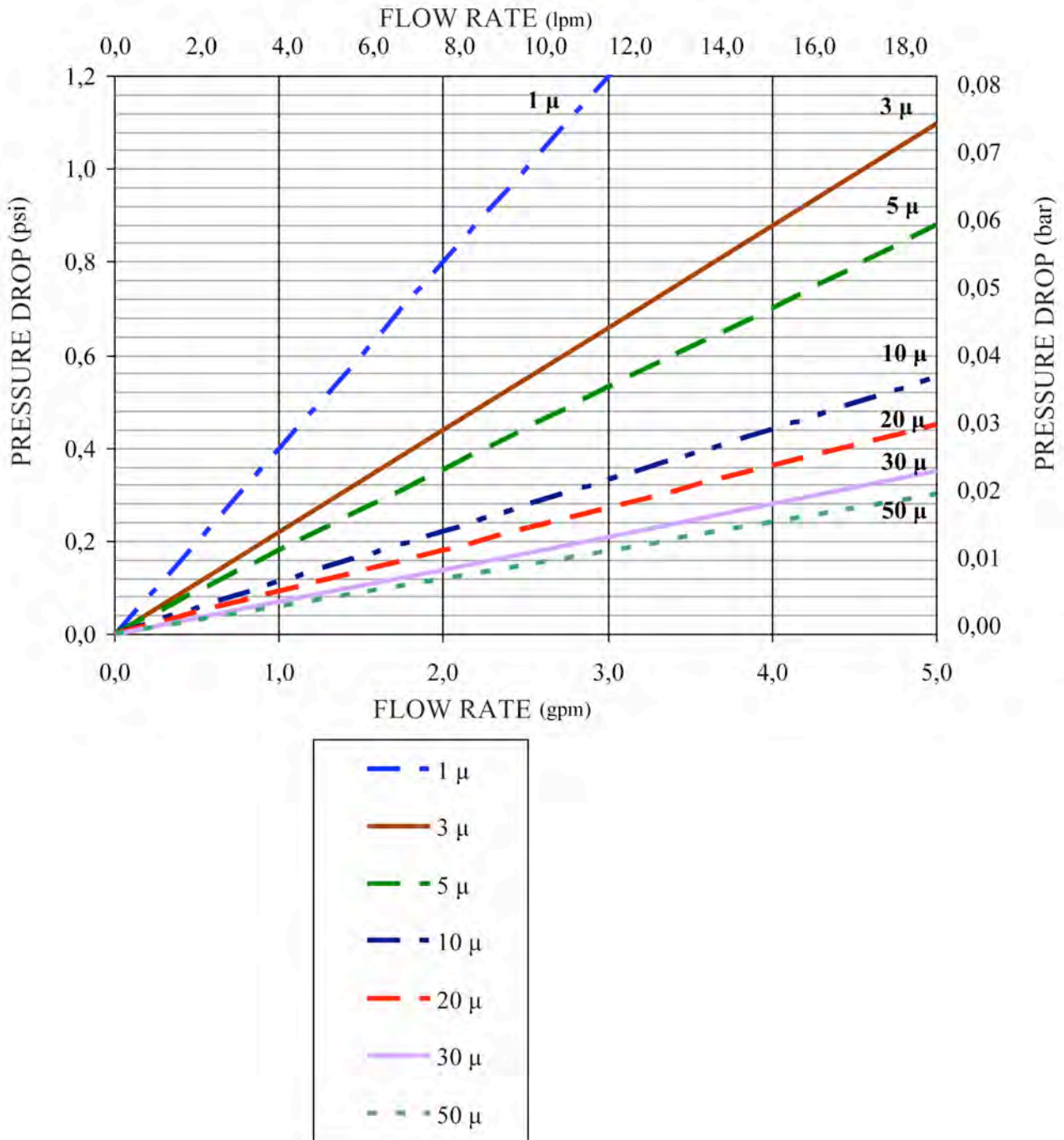

PP Big Sediment Filter Cartridges



- melt-blown polypropylene fibers;
- dimensions 114 mm external diameter;
- dimensions 28 mm internal diameter.



REF.	MODEL	LENGTH (inch)	MICRON	
FA038	DLPPBB-1-10	9 7/8"	1	
FA034	DLPPBB-5-10	9 7/8"	5	
FA035	DLPPBB-20-10	9 7/8"	20	
FA036	DLPPBB-50-10	9 7/8"	50	
FA039	DLPPBB-1-20	20"	1	
FA028	DLPPBB-5-20	20"	5	
FA029	DLPPBB-20-20	20"	20	
FA037	DLPPBB-50-20	20"	50	

PP Big Sediment Filter Cartridges



Flow – pressure drops diagram (Per single 10-inch equivalent)

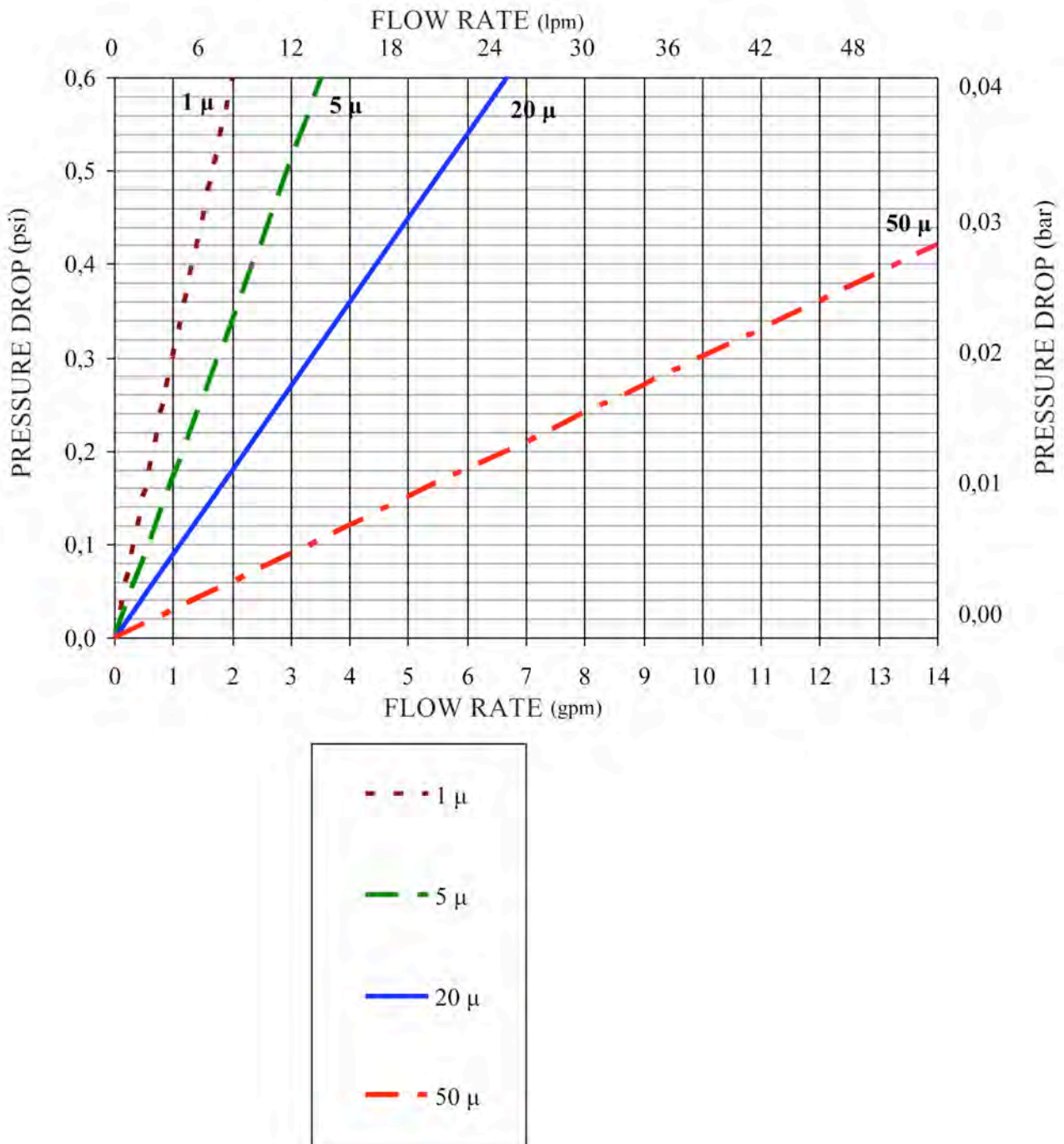

Purtrex Filtering Cartridges



- in melt-blown polypropylene fibers;
- any microfibers migration in filtered water;
- FDA materials compliant;
- graduated density from external to internal side improves filter efficiency;
- high retention capacity extends cartridge life;
- external diameter 63 mm, internal 27 mm;
- length 9 7/8" – 20" – 30" – 40".
- suggested filtration flow rate for 10" length: 15 ÷ 20 lpm;
- max filtration flow rate for 40" length: 60 lpm;
- max operating temperature = 80°C.



REF.	MODEL	LENGTH (inch)	MICRON	
FC010	PX 01 – 9 7/8"	9 7/8"	1	
FC011	PX 03 – 9 7/8"	9 7/8"	3	
FC012	PX 05 – 9 7/8"	9 7/8"	5	
FC013	PX 10 – 9 7/8"	9 7/8"	10	
FC014	PX 20 – 9 7/8"	9 7/8"	20	
FC015	PX 30 – 9 7/8"	9 7/8"	30	
FC016	PX 50 – 9 7/8"	9 7/8"	50	
FC017	PX 75 – 9 7/8"	9 7/8"	75	
FC020	PX 01 – 20"	20"	1	
FC021	PX 03 – 20"	20"	3	
FC022	PX 05 – 20"	20"	5	
FC023	PX 10 – 20"	20"	10	
FC024	PX 20 – 20"	20"	20	
FC025	PX 30 – 20"	20"	30	
FC026	PX 50 – 20"	20"	50	
FC030	PX 01 – 30"	30"	1	
FC031	PX 03 – 30"	30"	3	
FC032	PX 05 – 30"	30"	5	
FC033	PX 10 – 30"	30"	10	
FC034	PX 20 – 30"	30"	20	
FC035	PX 30 – 30"	30"	30	
FC036	PX 50 – 30"	30"	50	
FC040	PX 01 – 40"	40"	1	
FC041	PX 03 – 40"	40"	3	
FC042	PX 05 – 40"	40"	5	
FC043	PX 10 – 40"	40"	10	
FC044	PX 20 – 40"	40"	20	
FC045	PX 30 – 40"	40"	30	
FC046	PX 50 – 40"	40"	50	



Flow – pressure drops diagram (Per single 10-inch equivalent)

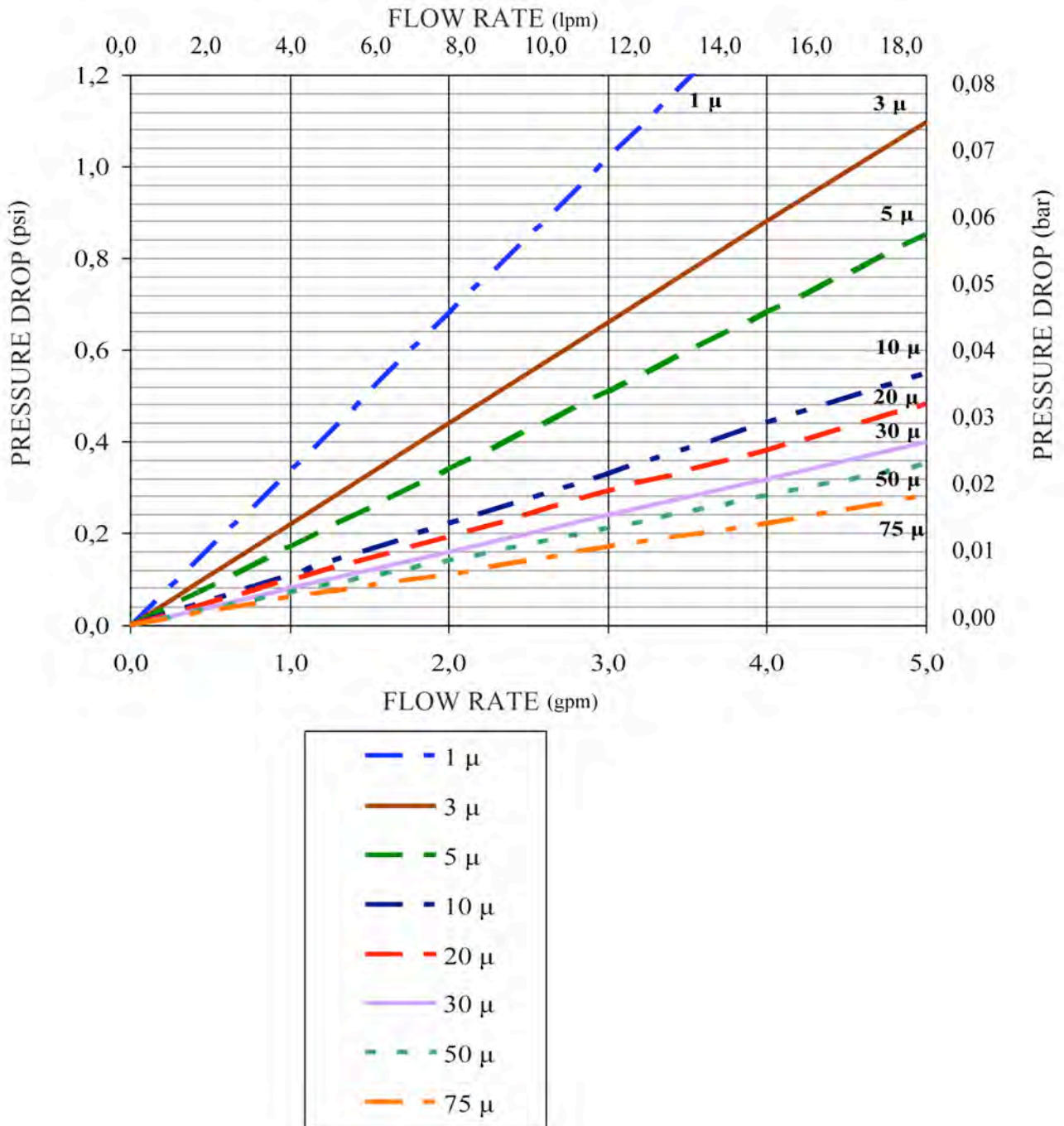

Activated Carbon Filtering Cartridges



Carbon Block

- Extruded activated carbon of Bituminous origin;
- Recommended for pre-filtration applications and for Chlorine removal;
- Dimensions:
 - external diameter = 64 mm (2 ½”);
 - internal diameter = 25 mm (1”)
 - end-cap diameter = 71 mm.

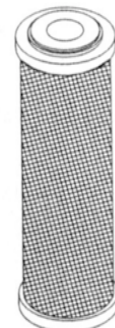

REF.	MODEL	LENGTH (inch)	MICRON	SUGGESTED FLOW RATE (l/h)	EXTRUDED ACTIVATED CARBON	CAP	
FA012	CBC 5”	5”	1	120	Bituminous	White	
FA013	EB-CB 9 7/8”	9 7/8”	10	240	Bituminous	White	
FA014	CBC 20”	20”	10	480	Bituminous	White	

Big Carbon Block

- Bituminous carbon block.
- Suitable for pre-filtration applications and for Chlorine removal.
- Dimensions:
 - external diameter = 108 mm (4 ¼”);
 - internal diameter = 25 mm (1”);
 - end-cap diameter = 113 mm.

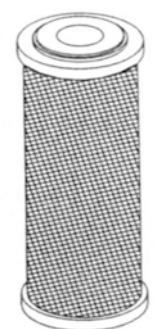

REF.	MODEL	LENGTH (inch)	MICRON	SUGGESTED FLOW RATE (l/h)	
FA016	CBC 10 BIG	10”	5	800	
FA015	CBC 20 BIG	20”	5	1600	



Wound PP & activated carbon

- wound polypropylene cartridge with granular activated carbon inside;
- external diameter 64 mm, internal 27 mm;
- length 9 7/8".

REF.	
FA058	



Granular activated carbon

- PE container cartridge empty or with granular activated carbon;
- external diameter 72 mm, length 9 7/8".

REF.	MODEL	DESCRIPTION	
FA007	GAC 10 N	WITH ACTIVATED CARBON	
FA008	10 N	EMPTY	



AISI 304 Cartridges for OTC Housings



AISI 304 Cartridges for OTC 12 Housings

- washable;
- to install with washable cartridge filters OTC 12 on catalogue (see 08-02-08-EN data sheet).

REF.	FILTRATION DEGREE (micron)	MATERIAL	
FB221	60	NYLON	

AISI 304 Cartridges for OTC 34 - 1 - 114 Housings

- washable;
- to install with washable cartridge filters OTC 34 – 1 - 114 on catalogue (see 08-02-08-EN data sheet) and with hot water filters, except for nylon filtering cartridge REF. FB224 (see 08-02-09-EN data sheet).

REF.	FILTRATION DEGREE (micron)	MATERIAL	
FB224	60	NYLON	
FB225	25	AISI 304	
FB228	60	AISI 304	
FB231	100	AISI 304	
FB234	200	AISI 304	
FB237	300	AISI 304	

AISI 304 Cartridges for OTC 112 - 2 Housings

- washable;
- to install with washable cartridge filters OTC 112 – 2 on catalogue (see 08-02-08-EN data sheet).

REF.	FILTRATION DEGREE (micron)	MATERIAL	
FB229	60	AISI 304	
FB232	100	AISI 304	
FB235	200	AISI 304	
FB238	300	AISI 304	



Nylon Filtering Cartridges

- washable;
- filtration degree 60 micron;
- dimensions external diameter 62 mm, internal 27 mm.

REF.	MODEL	LENGTH (inch)	
FA067	NL 60 - 9	9 ¾"	
FA068	NL 60 - 20	20"	



Special Nylon Filtering Cartridges for OTS Housings

- washable;
- to fit into OTS brass head housings 1 ¼" – 1 ½" – 2" models (see 08-02-11-EN data sheet);
- filtration degree 60 micron;
- with 222 O-rings;
- max ΔP recommended 1,4 bar.

REF.	LENGTH (inch)	Flow @ Δp=0,2 bar (l/h)	
FB067	10"	1800	
FB068	20"	3600	

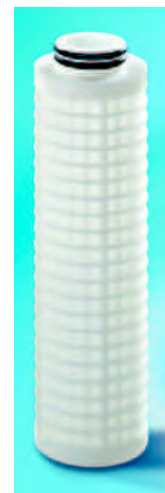

AISI 304 Filtering Cartridges

- washable;
- filtration degree 50 micron;
- length 9 ¾" ;
- you can fit them into hot water filter housings (see 08-02-09-EN data sheet).

REF.	MODEL	
FA850	SMOOTH	
FA900	PLEATED	

Ref. FA850



Ref. FA900





Nylon Reinforced Filtering Cartridge

- washable cartridge with PP reinforcement, nylon mesh and closing ring ;
- filtration degree 60 micron;
- dimensions external diameter 62 mm, internal 27 mm, length 9 ¾”;
- nylon mesh spare (REF. FB222).

REF.	
FA060	

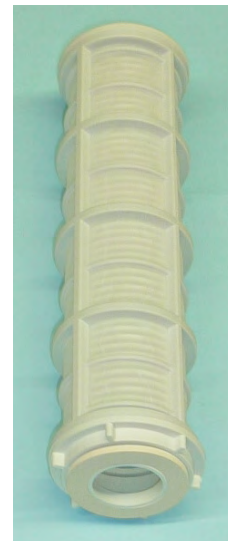

Wound Polypropylene with AISI 316 Core for Hot Water Filters

- filtration degree 20 micron;
- length 9 ¾”;
- max operating temperature 80°C;
- for relative spare parts see 08-02-09-EN data sheet.

REF.	MODEL	MICRON	
FA071	PAX 05 – 9 ¾”	5	
FA072	PAX 10 – 9 ¾”	10	
FA073	PAX 20 – 9 ¾”	20	
FA074	PAX 50 – 9 ¾”	50	





Empty Cartridges

- plastic empty cartridge;
- useful to fill with polyphosphate crystals – activated carbon - resins.

REF.	LENGTH (inch)	VOLUME (litres)	COLOUR	
FA064	9 ¾"	0,6	TRASPARENT	
FA064A (*)	20"	1,2	TRASPARENT	

(*) WARNING! The FA064A cartridge is not suitable for the FB049 housing of our catalogue.



PP Melt Blown 5" Filtering Cartridge

- melt blown polypropylene fibers cartridge;
- dimensions external diameter 64 mm, internal 25 mm.

REF.	MODEL	LENGTH (inch)	MICRON	
FA021	PP SED 05	5"	5	



Plastic Mini Filter Housings



- three pieces filter housing for MINI filtering cartridges 5" length;
- head and nut material ABS blue colour, sump in SAN clear;
- connections 1/2" with brass inserts;
- max operating pressure 7 bar;
- operating temperature 1 ÷ 45°C.



REF.	
FB024	

Cartridges to coupling:

Wound PP filament mini filter cartridges

- filtering degree 20 micron;
- dimensions external diameter 52 mm, internal 27 mm;
- length 5".

REF.	
FA065	



PP mini filtering cartridge

- washable MINI cartridge in wounded PP;
- filtering degree 70 micron;
- dimensions external diameter 50 mm, internal 27 mm;
- length 5".

REF.	
FA066	



Accessories

REF.	DESCRIPTION	
FB026	PLASTIC WRENCH	
FB028	DIFFUSOR KIT FOR GRANULAR MATERIAL	

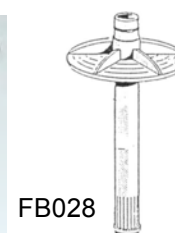

Residential Cintropur Filters



- range of filters for drinking water entirely made in synthetic material;
- the particular centrifugal effect causes the precipitation of larger particles, while the final filtration is assured by the filter sleeve;
- the filters include the sleeve at 25 micron;
- also available sleeves at 50 and 100 micron as spare parts;
- wrench and two complete connections included;
- max operating pressure 10 bar;
- max operating temperature 50°C.



REF.	MODEL	CONNECTIONS (inch)	Flow m ³ /h Δp 0,2 bar	HEIGHT (mm)	WIDTH (mm)	
FB401	NW 25 – ¾	¾"	5,5	355	270	
FB402	NW 25 – 1	1"	5,5	355	270	
FB403	NW 32 – 1 ¼	1 ¼"	6,5	540	270	

Accessories and spare parts

REF.	DESCRIPTION	
FB471	Drain cock ¼"	
FB472	Pressure gauge 1-10 bar - ⅛"	
FB473	Wall bracket in PP	
FB427	Set of 5 sleeves 25 micron for NW25	
FB428	Set of 5 sleeves 50 micron for NW25	
FB429	Set of 5 sleeves 100 micron for NW25	
FB433	Set of 5 sleeves 25 micron for NW32	
FB434	Set of 5 sleeves 50 micron for NW32	
FB435	Set of 5 sleeves 100 micron for NW32	

Industrial Cintropur Filters



- range of filters for drinking water entirely made in synthetic material;
- the particular centrifugal effect causes the precipitation of larger particles, while the final filtration is assured by the filter sleeve;
- the filters include the sleeve at 25 micron;
- also available sleeves at 5, 10, 50, 100, 150 and 300 micron as spare parts;
- wrench, pressure gauge and drain cock included;
- max operating pressure 10 bar;
- max pressure 16 bar;
- max operating temperature 50°C.



REF.	MODEL	Flow m ³ /h Δp 0,2 bar	WEIGHT (kg)	CONN.	Ø OF PIPE	A (mm)	B (mm)	
FB408A	NW 500 – 2	18	6,4	2" BSPT	2"	363	770	
FB409A	NW 650 – 2 ½	25	7,0	DN65	2 ½"	304	770	
FB410A	NW 800 – 3	32	7,4	DN80	3"	313	770	

Industrial Cintropur Filters



Accessories:



ITEM	REF.	DESCRIPTION	
33	FB487	NW500/650/800 air valve kit (with o-ring)	
50	FB480A	NW500/650 head	
51	FB482A	NW800 head	
52	FB483A	Turbine + screw	
53	FB484A	Filtering support armor	
54	FB485A	Cap cartridge	
55	FB486A	Head o-ring	
56	FB488A	Clear bowl	
58	FB489A	Black bowl	
59	FB490A	Diffusor kit	
60	FB491A	Drain valve adapter with o-ring	
61	FB491B	Drain cock 3/4"	
62	FB479	Wrench	
63	FB494A	Connection kit in plastic material + NW500 2" M adapter	
64	FB495A	NW650 DN65 flanged connection kit in plastic material	
65	FB496A	NW800 DN80 flanged connection kit in plastic material	
66	FB497A	Wall bracket in S.S.	
69	FB492	1/4" pressure gauge 0 ÷ 20 bar	
70	FB499	O-ring for NW500/650 connections	
71	FB499A	O-ring for NW800 connections	
NOT VIEWED	FB498	NW650 DN65 gasket in EPDM material	
NOT VIEWED	FB498A	NW800 DN80 gasket in EPDM material	
NOT VIEWED	FB437	Set of 5 sleeves 5 micron	
NOT VIEWED	FB438	Set of 5 sleeves 10 micron	
NOT VIEWED	FB439	Set of 5 sleeves 25 micron	
NOT VIEWED	FB440	Set of 5 sleeves 50 micron	
NOT VIEWED	FB441	Set of 5 sleeves 100 micron	
NOT VIEWED	FB442	Set of 5 sleeves 150 micron	
NOT VIEWED	FB443	Set of 5 sleeves 300 micron	

Plastic Filter Housings



- two pieces housing with fixable head;
- max operating pressure 8 bar;
- max operating temperature 35°C;
- IN/OUT connections 3/4";
- complete with air valve;
- fit standard cartridges 64 mm diameter length 9 3/4" or 20".

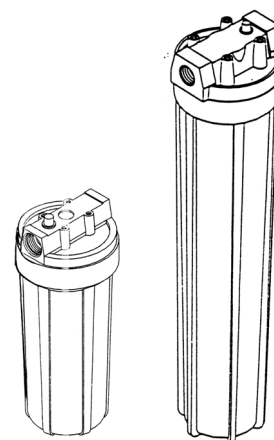

REF.	MODEL	FOR CARTRIDGE (inch)	HEAD MATERIAL AND COLOUR	SUMP MATERIAL AND COLOUR	HEAD DIMENSION (mm)	TOTAL LENGTH (mm)	
FB010	AS 1034	9 3/4"	PP blue	AS clear	124	295	
FB011	PP 1034	9 3/4"	PP blue	PP blue	124	295	
FB014	AS 2034	20"	PP black	AS clear	135	575	
FB015	PP 2034	20"	PP black	PP blue	135	575	

Plastic filter housings spare parts

AS 1034 & PP 1034 accessories

REF.	DESCRIPTION	
FB004	PLASTIC WRENCH	
FB007	MOUNTING BRACKET WHITE COATED MATERIAL	

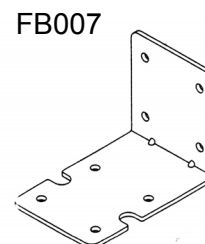
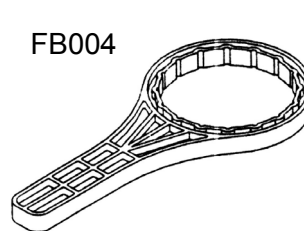

AS 2034 & PP 2034 accessories:

REF.	DESCRIPTION	
FB005	PLASTIC WRENCH	
FB007	MOUNTING BRACKET WHITE COATED MATERIAL	

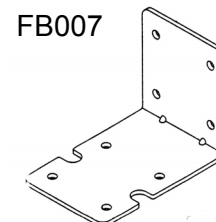
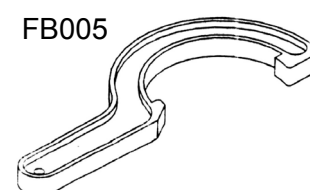

Plastic BIG Filter Housings



- two pieces filter housing with fixable head for 4 ½" diameter high flow cartridges;
- material polypropylene;
- max operating pressure 6,3 bar.

NOTE: a 5 bar set pressure gauge installation is recommended.



REF.	MODEL	CARTRIDGE LENGTH (inch)	IN/OUT CONNECTIONS (inch)	HEAD DIMENSION (mm)	TOTAL LENGTH (mm)	
FB017	BIG 10112	10"	1 ½" F	185	360	
FB017A	BIG 101	10"	1" F	185	360	
FB018	BIG 20112	20"	1 ½" F	185	605	
FB018A	BIG 201	20"	1" F	185	605	

Cartridges to coupling:

- BIG PP microfibre filtering cartridges, see 08-01-03-EN data sheet;
- BIG CARBON BLOCK filtering cartridges, see 08-01-05-EN data sheet.

Accessories:

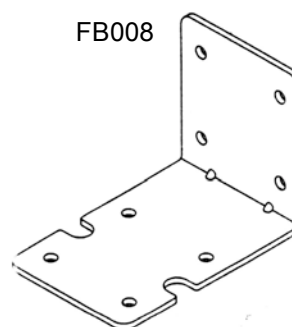
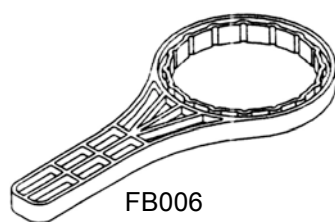

REF.	DESCRIPTION	
FB006	PLASTIC WRENCH	
FB008	MOUNTING BRACKET WHITE COATED METAL	

Plastic Filter Housings



- three pieces filter housings for standard filtering cartridges external diameter max 64 mm, length 9 ¾" or 20";
- head and nut material PP blue colour, sump in SAN clear;
- max operating pressure 7 bar;
- operating temperature 1 ÷ 45° C;
- fixable head version;
- connections ¾" and 1" with brass inserts;
- complete with air valve.



(*) WARNING! The FA064A cartridge of our catalogue is not suitable for this housing.

REF.	MODEL	CARTRIDGE LENGTH (inch)	CONNECTIONS (inch)	HEAD DIMENSION (mm)	TOTAL LENGTH (mm)	
FB022	FS3P 34-9	9 ¾"	¾"	132	315	
FB023	FS3P 1-9	9 ¾"	1"	132	315	
FB049 (*)	FS3P 1-20	20"	1"	132	570	

Accessories



OLD



NEW

FB025A



FB027B - FB027C



FB029A - FB030A



FB038

REF.	DESCRIPTION	
FB025A	PLASTIC WRENCH	
FB027B	¾" NIPPLE WITH O-RINGS	
FB027C	1" NIPPLE WITH O-RINGS	
FB029A	PLASTIC MOUNTING BRACKET WHITE FOR ONE FILTER	
FB030A	PLASTIC MOUNTING BRACKET WHITE FOR TWO FILTERS	
FB038	DIFFUSOR KIT FOR GRANULAR MATERIAL FOR 9 ¾"	

Self Cleaning Filters



- range of sediment self clearing filters, chrome plated brass head and trogamid sump, with pleated AISI 304 cartridge at 100 micron (on request available also at 25, 60, 200 and 300 micron);
- complete with manometer on inlet;
- opening the drain valve, a depression is created inside the sump, that lowers the cartridge and reverts the clearing water flow. Closing the valve, the cartridge rises and places the filter in service again. Repeat the action 4-5 times for about 10 seconds each time;
- easy cartridge disassembly in case of inspection or replacement;
- for 3/4" ÷ 2" models, on demand available models with automatic cleaning controller (AOTC AUT Models);
- D.M. n.174 dated 06/04/2004 compliant about materials suitable for contact with water for human consumption;
- IN/OUT connections 1/2" F;
- max operating pressure 16 bar;
- temperature 0 ÷ 40° C;
- max ΔP recommended 1 bar.

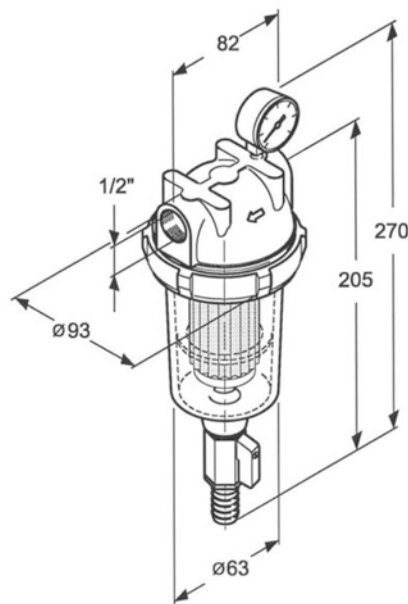

REF.	MODEL	IN-OUT connection	Flow @ Δp=0,2 bar (l/h)	
FB210B	AOTC 12	1/2" F	1500	

Self Cleaning Filters

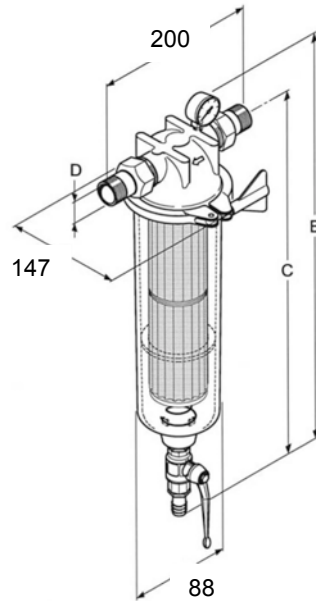

REF.	MODEL	C	D IN-OUT connection GAS	E	Flow @ $\Delta p=0,2$ bar (l/h)
FB211B	AOTC 34	365	3/4"	460	3000
FB211BT (*)	AOTC 34 AUT	365	3/4"	460	3000
FB212B	AOTC 1	365	1"	460	3500
FB212BT (*)	AOTC 1 AUT	365	1"	460	3500
FB213B	AOTC 114	375	1 1/4"	470	4500
FB213BT (*)	AOTC 114 AUT	375	1 1/4"	470	4500

- max operating pressure 10 bar;
- temperature 0 ÷ 40°C;
- max ΔP recommended 1 bar.

REF.	MODEL	D IN-OUT connection GAS	Flow @ $\Delta p=0,2$ bar (l/h)
FB214B	AOTC 112	1 1/2" F	10000
FB214BT (*)	AOTC 112 AUT	1 1/2" F	10000
FB215B	AOTC 2	2" F	15000
FB215BT (*)	AOTC 2 AUT	2" F	15000

(*) not available in stock.

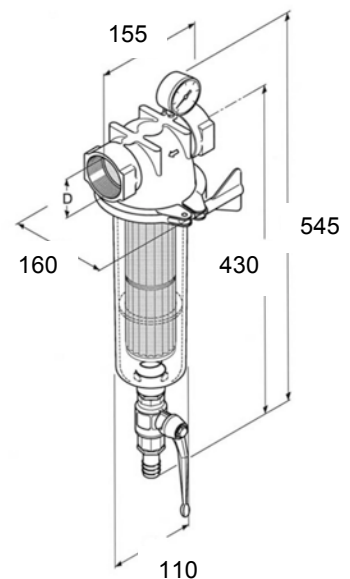

Filters with Washable Cartridge



- range of sediment filters, chrome plated brass head and trogamid sump, complete with washable cartridge;
- available AISI 304 cartridges and versions with AISI 316 sump for temperature up to 80°C (only ¾" – 1" – 1 ¼" models): please see 08-01-07-EN data sheet.

- max operating pressure 16 bar;
- temperature 0 ÷ 40° C;
- nylon cartridge 60 micron (REF. FB221).

REF.	MODEL	IN-OUT connection	Flow at $\Delta p=0,2$ bar (l/h)	
FB200	OTC 12	½" F	1200	

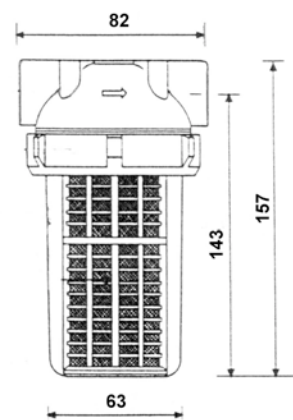

- max operating pressure 16 bar;
- temperature 0 ÷ 40° C;
- nylon cartridge 60 micron (REF. FB224).

REF.	MODEL	IN-OUT connection	Flow at $\Delta p=0,2$ bar (l/h)	
FB201	OTC 34	¾"	3000	
FB202	OTC 1	1"	3500	
FB203	OTC 114	1¼"	5000	

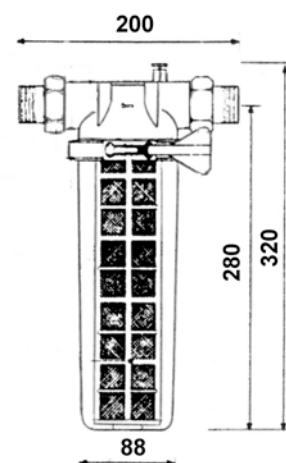

- max operating pressure 10 bar;
- temperature 0 ÷ 40° C;
- AISI 304 cartridge 100 micron (REF. FB232).

REF.	MODEL	IN-OUT connection	Flow at $\Delta p=0,2$ bar (l/h)	
FB204B	OTC 112	1½" F	10000	
FB205B	OTC 2	2" F	15000	

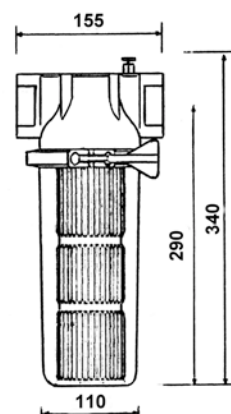

Hot Water Filters



- filter housing brass chromium-pleated head with sump in AISI 304, for standard filtering cartridges external diameter max 64 mm, and length 9 3/4", 10" or 20";
- complete with internal tie-rod in AISI 304 to fit cartridges;
- max operating temperature 80°C;
- max operating pressure 16 bar;
- complete with air valve.

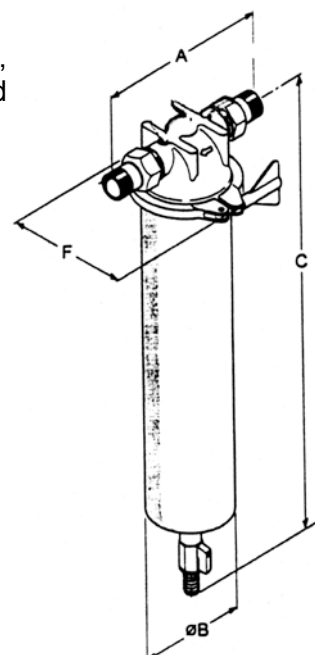

Note: for MODEL 20", you can put one 10" filtering cartridge on another.

REF.	MODEL	CONNECTIONS (inch)	LENGTH (inch)	A (mm)	B (mm)	C (mm)	F (mm)	
FB217	OTC-HW 34	3/4"	10"	200	88	375	147	
FB218	OTC-HW 1	1"	10"	200	88	375	147	
FB219	OTC-HW 114	1 1/4"	10"	200	88	385	147	
FB217A	OTC-HW 34-20	3/4"	20"	200	88	630	147	
FB218A	OTC-HW 1-20	1"	20"	200	88	630	147	
FB219A	OTC-HW 114-20	1 1/4"	20"	200	88	640	147	

Cartridges to coupling:

- AISI 304 pleated filtering cartridges, REF. FB225, FB228, FB231, FB234 and FB237 (see 08-01-07-EN data sheet);
- AISI 304 filtering cartridges, REF. FA850 and FA900 (see 08-01-08-EN data sheet).

Filter Housings Brass Head



- three pieces filter housings;
- head and nut material brass nickel-pleated, sump in SAN clear;
- max operating pressure 8 bar;
- operating temperature 1 ÷ 40° C;
- complete with air valve;
- ATTENTION: the ¾" and 1" models fit standard filtering cartridges external diameter max 64 mm and length 9 ¾";
- The 1 ¼" – 1 ½" – 2" models fit only the special cartridges nylon mesh length 10" or 20".



REF.	MODEL	CONNECTIONS (inch)	FOR CARTRIDGE	L (mm)	H (mm)	CARTRIDGE TYPE	
FB060	OTS 34- 9	¾"	9 ¾"	135	330	standard	
FB061	OTS 1- 9	1"	9 ¾"	135	330	standard	
FB062	OTS 1-20	1"	20"	135	600	standard	
FB063	OTS 114-10	1 ¼"	10"	150	340	special	
FB064	OTS 114-20	1 ¼"	20"	150	620	special	
FB072	OTS 112-10	1 ½"	10"	150	340	special	
FB065	OTS 112-20	1 ½"	20"	150	620	special	
FB073	OTS 2-10	2"	10"	162	360	special	
FB066	OTS 2-20	2"	20"	162	640	special	

Special cartridges

- special cartridges nylon mesh for OTS filter housings CONNECTIONS 1 ¼" – 1 ½" – 2", see 08-01-08-EN data sheet.

Accessories

Wrench

- galvanised steel material.

REF.	
FB069	



AISI 316 Filter Housings



- multicartridges filter housings flanged top opening AISI 316L for 3 cartridges, support legs, In/Out connections 2" BSP M or DN50 flange;
- two 1/2" BSP connections for air valve pressure gauge and for drain filter;
- high resistance and strength electrowelded construction, complete with AISI 316 fixing cartridges accessories, glass blasted internal and outside treatment;
- European 97/23/EC Directive compliant for pressure equipment (PED);
- max operating temperature = 10 bar;
- hydraulic test pressure = 15 bar;
- max operating temperature 80 °C;
- gasket material EPDM;
- suitable for DOE cartridges;
- cartridges dimensions: ID min/max 26÷30 mm, OD max 70 mm and length 20"- 30"- 40".

WARNING! The FA014 cartridge of our catalogue is not suitable for these housings.



REF.	MODEL	CARTRIDGES NUMBER	IN/OUT CONNECTIONS	A (mm)	WEIGHT (kg)	
FB040	CFH 3 x 20"	3 x 20"	2" BSP M	1200	20	
FB040A (*)	CFH 3 x 20"	3 x 20"	DN50 Flange	1200	22	
FB041	CFH 3 x 30"	3 x 30"	2" BSP M	1500	21	
FB041A (*)	CFH 3 x 30"	3 x 30"	DN50 Flange	1500	23	
FB041/1	CFH 3 x 40"	3 x 40"	2" BSP M	1600	22	
FB041/1A (*)	CFH 3 x 40"	3 x 40"	DN50 Flange	1600	24	

(*) flanged version on demand not available in stock – Delivery 2-3 weeks.

AISI 316 Filter Housings

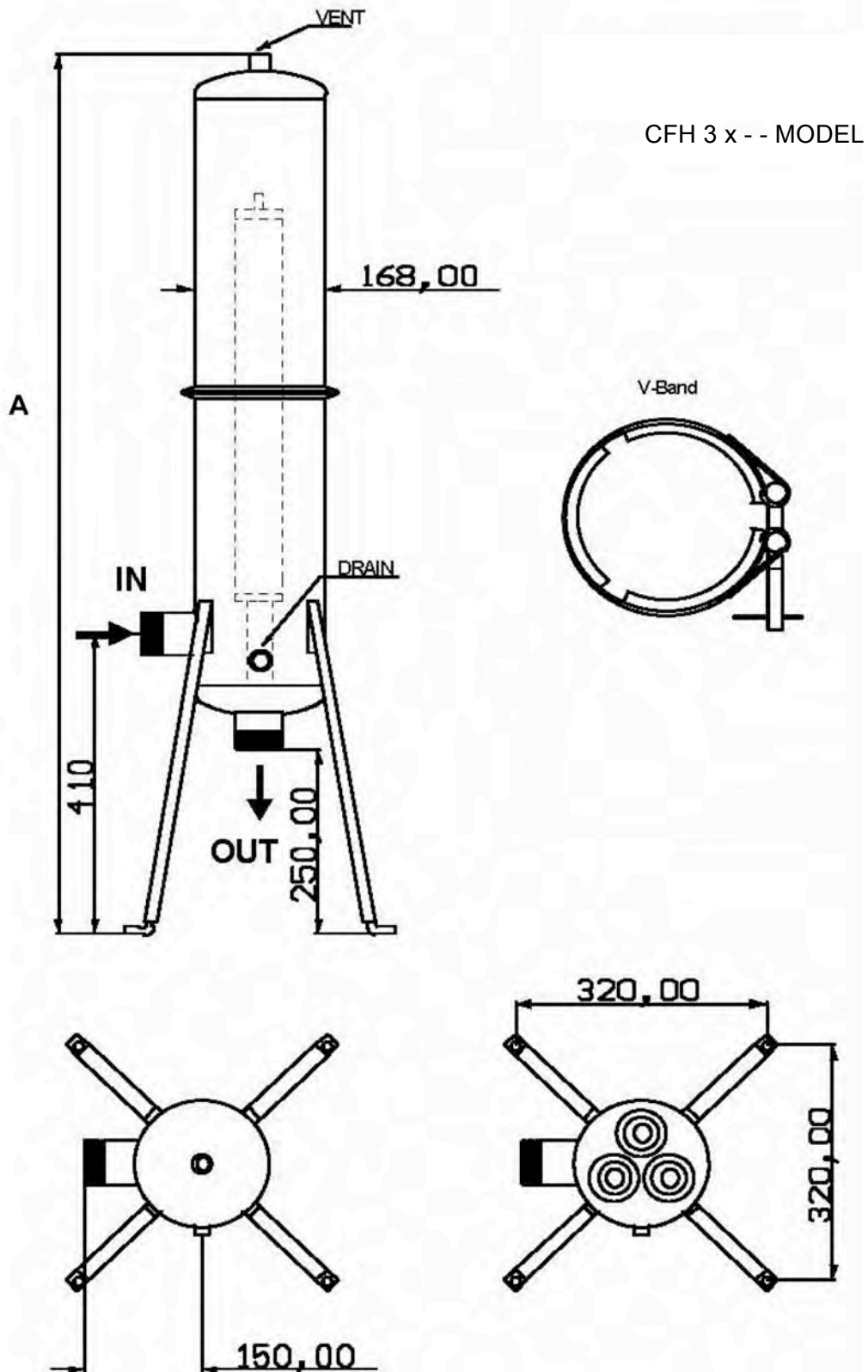

AISI 316 Filter Housings



- multicartridges filter housings flanged top opening AISI 316L for 7 cartridges, support legs, In/Out connections 2 ½" BSP M or DN65 flange;
- two ½" BSP connections for air valve pressure gauge and for drain filter;
- high resistance and strength electrowelded construction, complete with AISI 316 fixing cartridges accessories, glass blasted internal and outside treatment;
- European 97/23/EC Directive compliant for pressure equipment (PED);
- max operating temperature = 10 bar;
- hydraulic test pressure = 15 bar;
- max operating temperature 80 °C;
- gasket material EPDM;
- suitable for DOE cartridges;
- cartridges dimensions: ID min/max 26÷30 mm, OD max 70 mm and length 20"- 30"- 40".



WARNING! The FA014 cartridge of our catalogue is not suitable for these housings.

REF.	MODEL	CARTRIDGES NUMBER	IN/OUT CONNECTIONS	A (mm)	WEIGHT (kg)	
FB042	CFH 7 x 20"	7 x 20"	2 ½" BSP M	1190	27	
FB042A (*)	CFH 7 x 20"	7 x 20"	DN65 Flange	1190	30	
FB043	CFH 7 x 30"	7 x 30"	2 ½" BSP M	1495	29	
FB043A (*)	CFH 7 x 30"	7 x 30"	DN65 Flange	1495	32	
FB044	CFH 7 x 40"	7 x 40"	2 ½" BSP M	1610	34	
FB044A (*)	CFH 7 x 40"	7 x 40"	DN65 Flange	1610	37	

(*) flanged version on demand not available in stock – Delivery 2-3 weeks.

AISI 316 Filter Housings

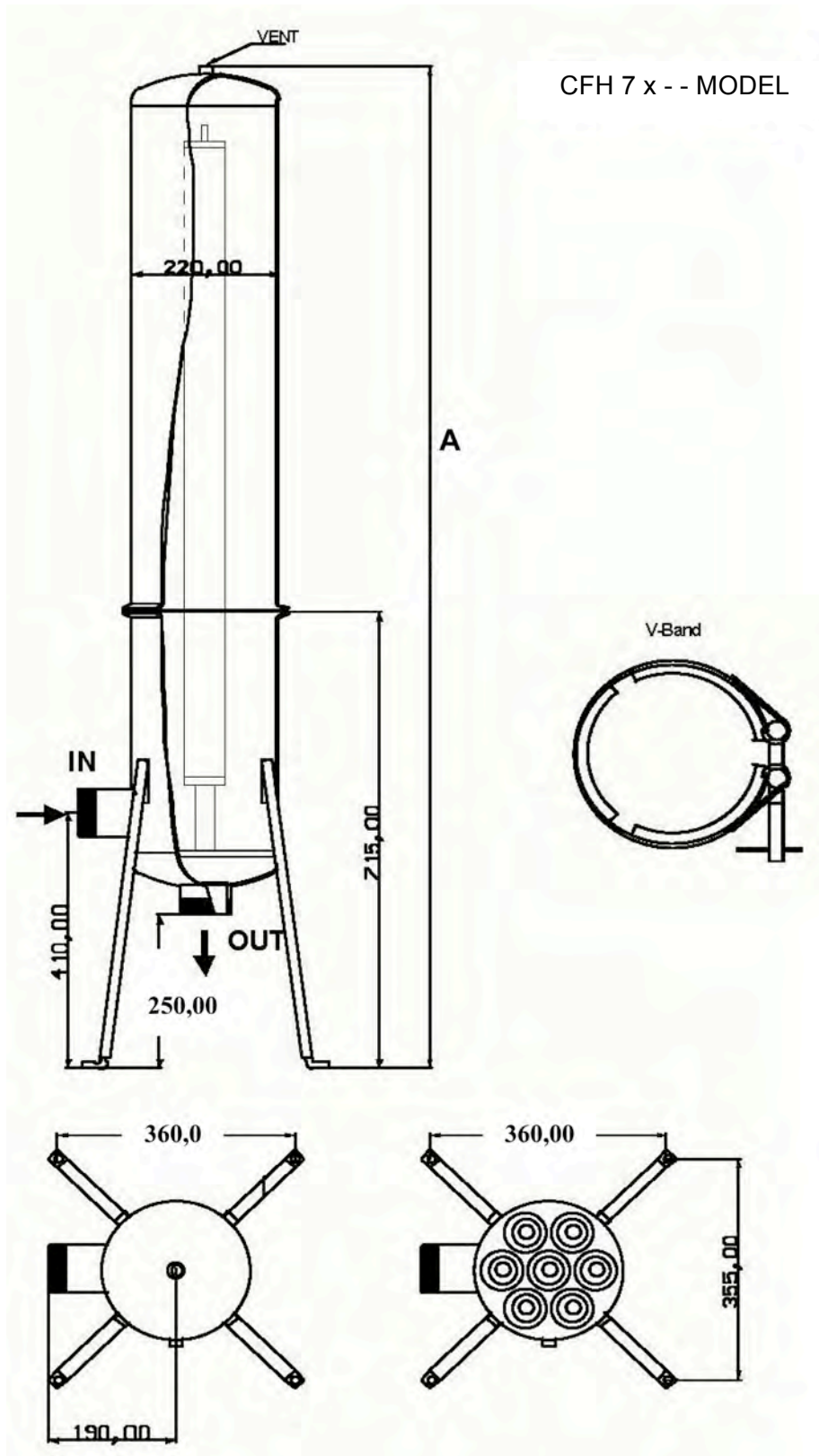

AISI 316 Filter Housings



- multicartridges filter housings flanged top opening AISI 316L for 15 cartridges, support legs, In/Out connections DN100;
- two 1/2" BSP connections for air valve pressure gauge and for drain filter;
- high resistance and strength electrowelded construction, complete with AISI 316 fixing cartridges accessories, glass blasted internal and outside treatment;
- European 97/23/EC Directive compliant for pressure equipment (PED);
- max operating temperature = 10 bar;
- hydraulic test pressure = 15 bar;
- max operating temperature 80 °C;
- gasket material EPDM;
- suitable for DOE cartridges;
- cartridges dimensions: ID min/max 26÷30 mm, OD max 68 mm and length 30"- 40".

WARNING! The FA014 cartridge of our catalogue is not suitable for these housings.



REF.	MODEL	CARTRIDGES NUMBER	IN/OUT CONNECTIONS	A (mm)	WEIGHT (kg)	
FB045	CFH 15 x 30"	15 x 30"	DN100 Flange	1500	75	
FB046	CFH 15 x 40"	15 x 40"	DN100 Flange	1750	80	

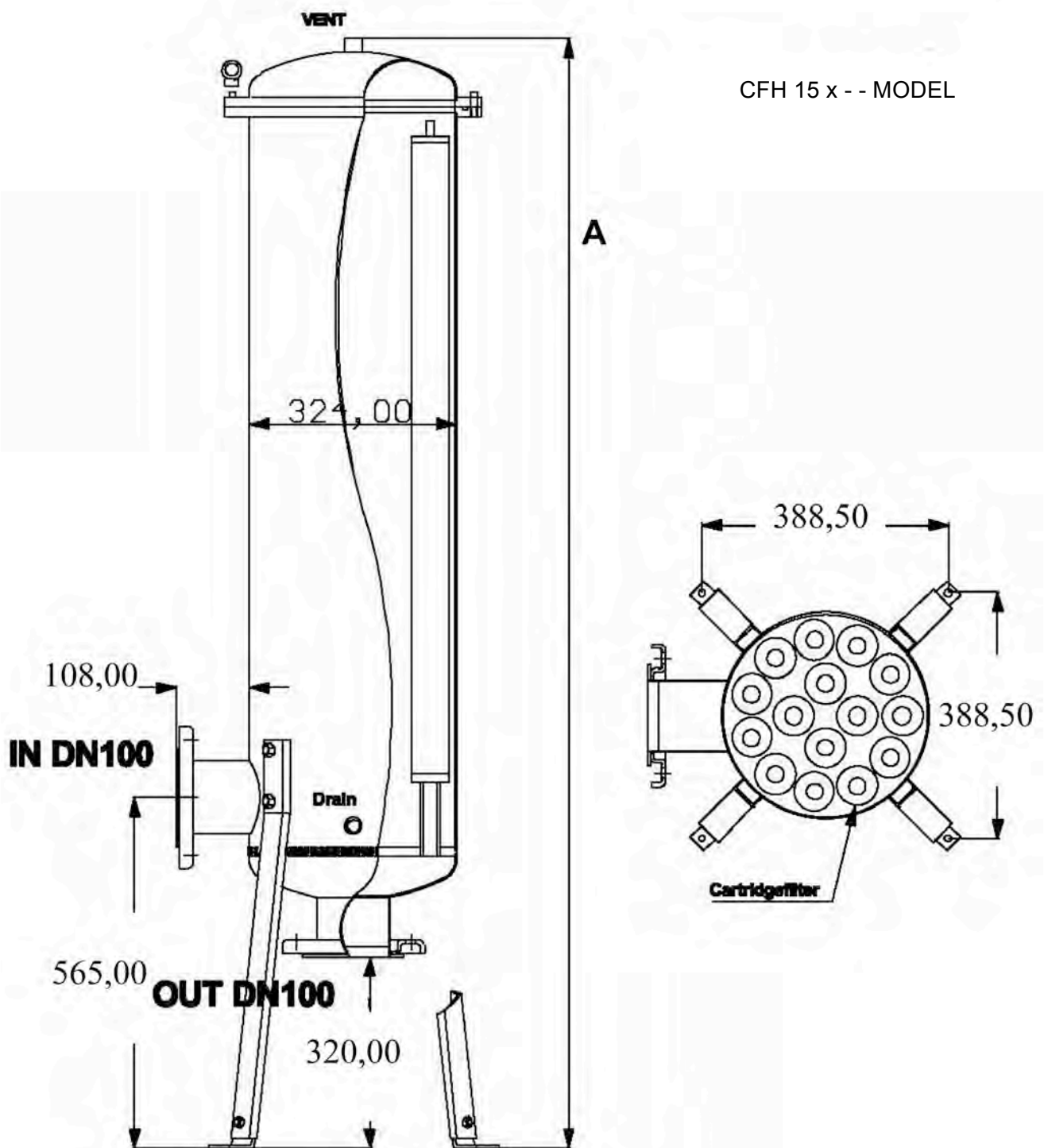

AISI 316 Filter Housings



- multicartridges filter housings flanged top opening AISI 316L for 22 cartridges, In/Out connections DN150;
- three ½" BSP connections for air valve pressure gauge and for drain filter;
- high resistance and strength electrowelded construction, complete with AISI 316 fixing cartridges accessories, glass blasted internal and outside treatment;
- European 97/23/EC Directive compliant for pressure equipment (PED);
- max operating temperature = 10 bar;
- hydraulic test pressure = 15 bar;
- max operating temperature 80 °C;
- gasket material EPDM;
- suitable for DOE cartridges;
- cartridges dimensions: ID min/max 26÷30 mm, OD max 70 mm and length 40".

WARNING! The FA014 cartridge of our catalogue is not suitable for these housings.



REF.	MODEL	CARTRIDGES NUMBER	IN/OUT CONNECTIONS	WEIGHT (kg)	
FB046/1	CFH 22 x 40"	22 x 40"	DN150 Flange	138	



CFH 22 x 40 MODEL

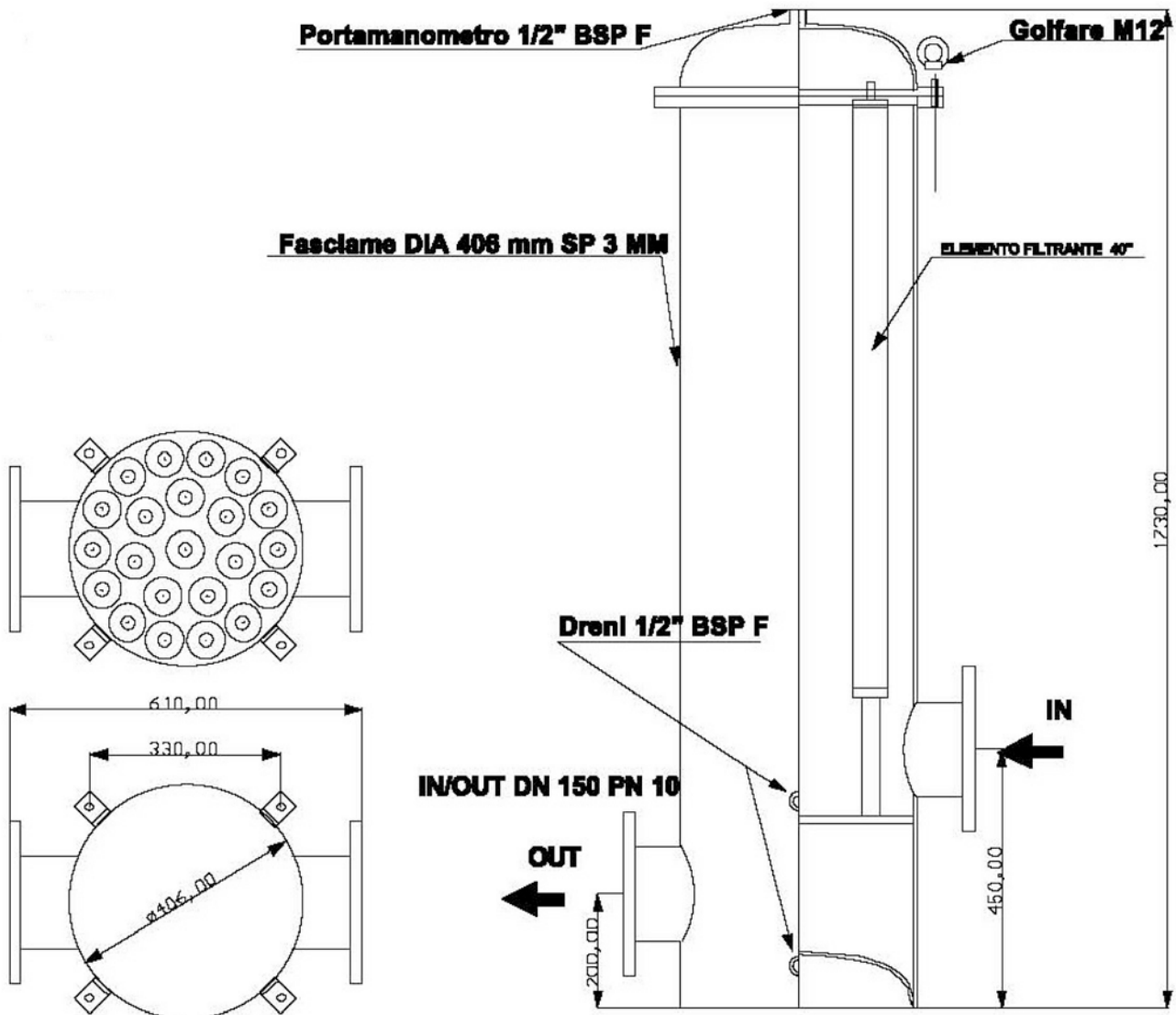

Chemical High Resistance PVC-U Multicartridges Filter Housings HPCF Series



- PVC-U multicartridges filter housings for 5 cartridges flanged top opening;
- with three pieces in / out female socket weld connections;
- with two 1/4" threaded connections for air valve pressure gauges and for drain filter;
- all filter housing internal material and all internal spare parts are in PVC-U for high chemical corrosion resistance;
- opening gasket in silicone material;
- connection gasket in EPDM material;
- with aeration valve and pressure gauge;
- European 97/23/EC Directive compliant for pressure equipment (PED);
- design pressure = 6,0 bar @ 25°C;
- hydraulic test pressure = 7,8 bar;
- max Δp = 1,4 bar;
- operating temperature = 5 ÷ 40 °C;
- In/Out connections DN50 / D. 63 mm;
- suitable for DOE cartridges;
- cartridges dimensions: ID 28÷30 mm, OD 65÷71 mm and length 20"- 30"- 40".



WARNING! The FA014 cartridge of our catalogue is not suitable for these housings.

REF.	MODEL	CARTRIDGES NUMBER	WEIGHT (kg)	CAPACITY (litres)	NOMINAL FLOW RATE (lpm)	
FB560	HPCF/B-5DC2	n.5 2,5" x 20"	11,0	20,6	300	
FB561	HPCF/B-5DC3	n.5 2,5" x 30"	12,7	29,4	300	
FB562	HPCF/B-5DC4	n.5 2,5" x 40"	14,4	38,2	300	

Chemical High Resistance PVC-U Multicartridges Filter Housings HPCF Series

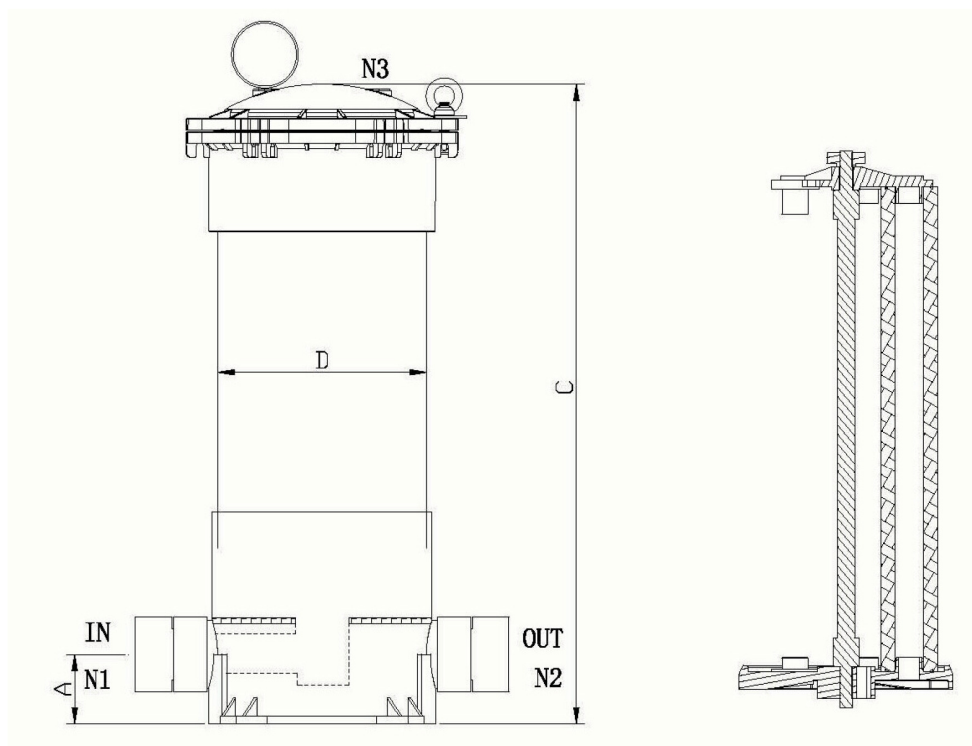
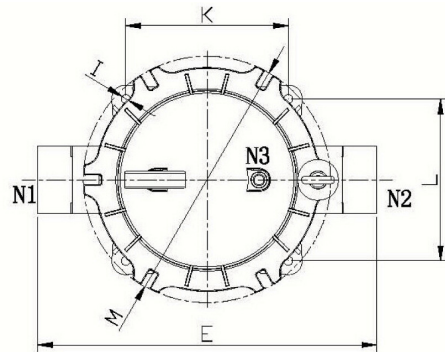

REF.	MODEL	A *	C *	D *	E *	I *	K *	L *	M *	N1 N2 *	N3
FB560	HPCF/B-5DC2	75	730	225	482	10	187,5	186	290	63	G 1/4"
FB561	HPCF/B-5DC3	75	980	225	482	10	187,5	186	290	63	G 1/4"
FB562	HPCF/B-5DC4	75	1230	225	482	10	187,5	186	290	63	G 1/4"

* Dimensions are in mm.

Chemical High Resistance PVC-U Multicartridges Filter Housings HPCF Series



- PVC-U multicartridges filter housings for 9 cartridges flanged top opening;
- with three pieces in / out female socket weld connections;
- with two 1/4" threaded connections for air valve pressure gauges and for drain filter;
- all filter housing internal material and all internal spare parts are in PVC-U for high chemical corrosion resistance;
- opening gasket in silicone material;
- connection gasket in EPDM material;
- with aeration valve and pressure gauge;
- European 97/23/EC Directive compliant for pressure equipment (PED);
- design pressure = 6,0 bar @ 25°C;
- hydraulic test pressure = 7,8 bar;
- max Δp = 1,4 bar;
- operating temperature = 5 ÷ 40 °C;
- In/Out connections DN80 / D. 90 mm;
- 1" BSPT M (+ F 20 mm to glue) drain connection;
- suitable for DOE cartridges;
- cartridges dimensions: ID 28÷30 mm, OD 65÷71 mm and length 20"- 30"- 40".



WARNING! The FA014 cartridge of our catalogue is not suitable for these housings.

REF.	MODEL	CARTRIDGES NUMBER	WEIGHT (kg)	CAPACITY (litres)	NOMINAL FLOW RATE (lpm)	
FB564	HPCF/B-9DC2	n.9 2,5" x 20"	20,0	39,7	250	
FB565	HPCF/B-9DC3	n.9 2,5" x 30"	23,0	57,0	350	
FB566	HPCF/B-9DC4	n.9 2,5" x 40"	26,0	74,3	550	

Chemical High Resistance PVC-U Multicartridges Filter Housings HPCF Series

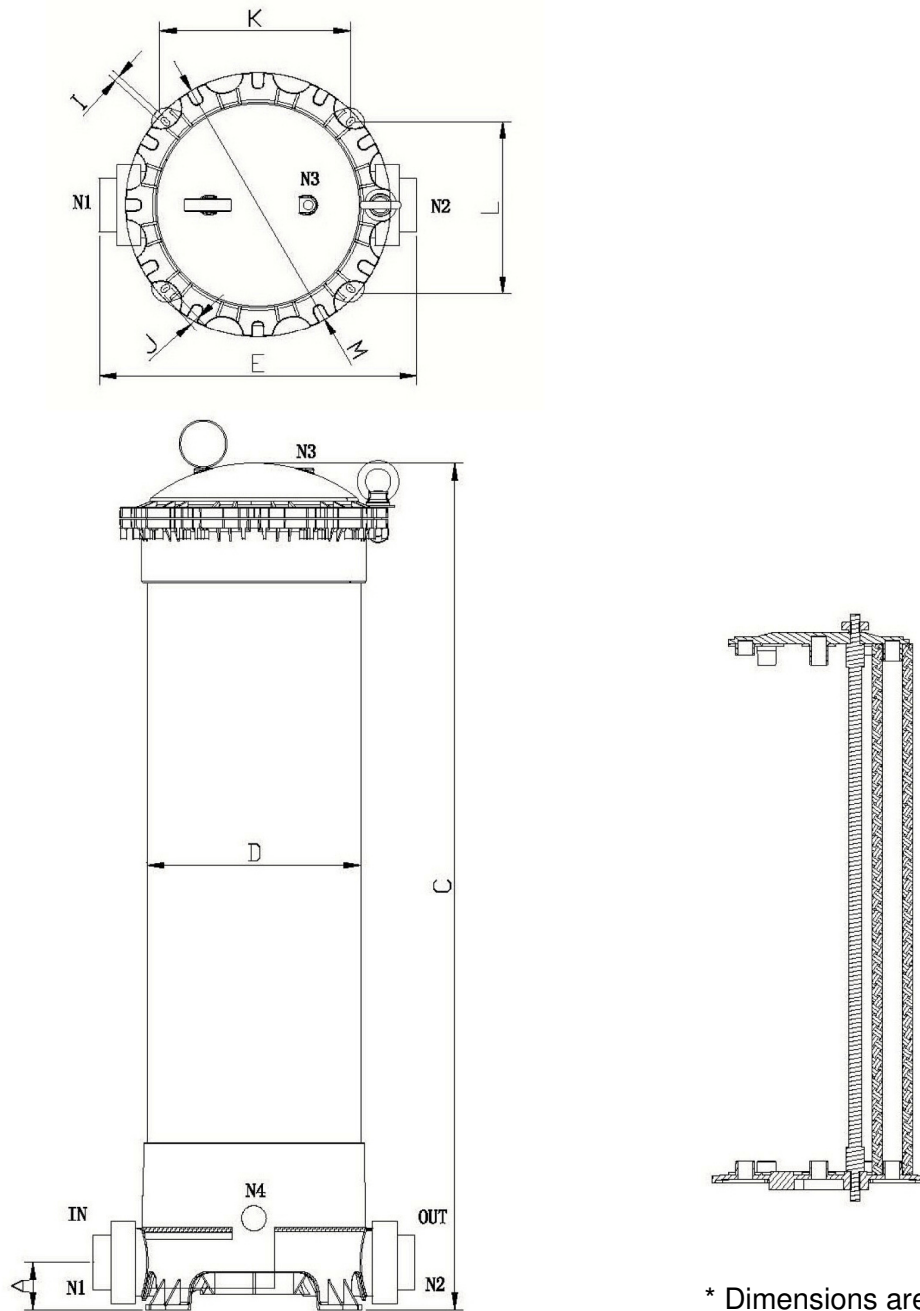

* Dimensions are in mm.

REF.	MODEL	A *	C *	D *	E *	I *	J *	K *	L *	M *	N1 N2 *	N3	N4
FB564	HPCF/B-9DC2	69	765	315	520	9	15	276	249	372	90	G 1/4"	1"
FB565	HPCF/B-9DC3	69	1015	315	520	9	15	276	249	372	90	G 1/4"	1"
FB566	HPCF/B-9DC4	69	1265	315	520	9	15	276	249	372	90	G 1/4"	1"

High Flow PVC-U Single Cartridge Filter Housings PF Series



- PVC-U single cartridge filter housings, with flanged top opening, support legs, in/out female socket weld connections and two ¼" threaded connections for air valve pressure gauges and for drain filter;
- all filter housing internal material and all internal spare parts are in PVC-U for high chemical corrosion resistance;
- opening gasket in silicone material;
- connection gasket in EPDM material;
- with aeration valve and pressure gauge;
- European 97/23/EC Directive compliant for pressure equipment (PED);
- design pressure = 7,0 bar @ 25 °C;
- hydraulic test pressure = 9,1 bar;
- max Δp = 1,4 bar;
- operating temperature = 5 ÷ 40 °C;
- In/Out flanged connections DN50;
- suitable for high flow "special pleated cartridges";
- cartridges dimensions: 6" x 20" and 6" x 40".



REF.	MODEL	CARTRIDGES NUMBER	WEIGHT (kg)	CAPACITY (litres)	NOMINAL FLOW RATE (lpm)	
FB360	PF20	n.1 6" x 20"	18,0	24,8	300	
FB361	PF40	n.1 6" x 40"	22,3	41,0	300	

Cartridge to coupling

- high flow "special pleated cartridges" single open-ended;
- filter media and support in PP, o-ring seal in EPDM;
- end caps in fiberglass reinforced PP;
- inside to outside flow pattern;
- external diameter = 6" (152 mm);
- recommended maximum ΔP 1,0 bar at 20 °C.



REF.	MODEL	LENGTH (inch)	MICRON	NOMINAL FLOW RATE (lpm)	
FB376	DLHF620PP4.5E	20"	4,5	660	
FB379	DLHF620PP20E	20"	20	660	
FB381	DLHF620PP70E	20"	70	660	
FB382	DLHF620PP100E	20"	100	660	
FB386	DLHF640PP4.5E	40"	4,5	1300	
FB389	DLHF640PP20E	40"	20	1300	
FB391	DLHF640PP70E	40"	70	1300	
FB392	DLHF640PP100E	40"	100	1300	

High Flow PVC-U Single Cartridge Filter Housings PF Series

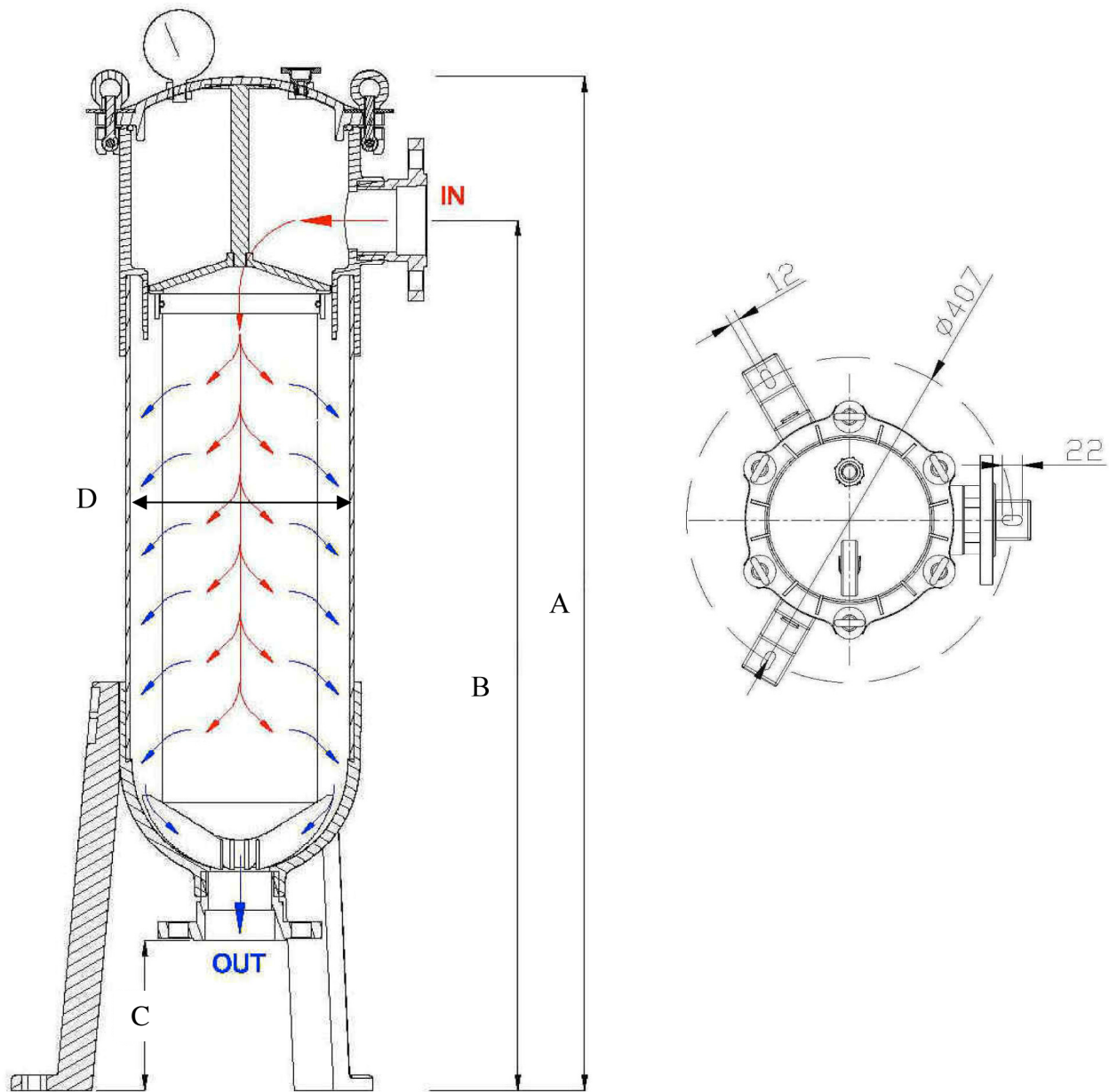

REF.	MODEL	A *	B *	C *	D *
FB360	PF20	1070	905	165	225
FB361	PF40	1560	1395	165	225

* Dimensions are in mm.

PVC-U Bag Filter System



- PVC-U bag filter housings, with flanged top opening, support legs, in/out female socket weld connections and two 1/4" threaded connections for air valve pressure gauges and for drain filter;
- all filter housing internal material and all internal spare parts are in PVC-U for high chemical corrosion resistance;
- Opening gasket in silicone material;
- Connection gasket in EPDM material;
- With aeration valve and pressure gauge;
- European 97/23/EC Directive compliant for pressure equipment (PED);
- Nominal flow rate = 300 lpm;
- Design pressure = 7,0 bar @ 25°C;
- Hydraulic test pressure = 9,1 bar;
- Max Δp = 1,0 bar;
- Operating temperature = 5 ÷ 40 °C;
- In/Out flanged connections DN50;
- Suitable for bag filter;
- Bag filters dimensions: 7" x 16" and 7" x 32".



REF.	MODEL	BAG SIZE	WEIGHT (kg)	CAPACITY (litres)	
FB355	HXP-BF-1-1-B	7" x 16"	15	17	
FB356	HXP-BF-1-2-B	7" x 32"	20	30	

Bag filters to coupling

- Inside to outside flow pattern;
- In PP material;
- External diameter = 7" (178 mm);
- Recommended maximum Δp = 1,0 bar at 20°C.



REF.	MODEL	LENGTH (inch)	MICRON	NOMINAL FLOW RATE (lpm)	
FB357A	BAG FILTER 1	16"	1	330	
FB357B	BAG FILTER 1	16"	5	330	
FB357C	BAG FILTER 1	16"	10	330	
FB357D	BAG FILTER 1	16"	25	330	
FB357E	BAG FILTER 1	16"	50	330	
FB357F	BAG FILTER 1	16"	100	330	
FB358A	BAG FILTER 2	32"	1	660	
FB358B	BAG FILTER 2	32"	5	660	
FB358C	BAG FILTER 2	32"	10	660	
FB358D	BAG FILTER 2	32"	25	660	
FB358E	BAG FILTER 2	32"	50	660	
FB358F	BAG FILTER 2	32"	100	660	

PVC-U Bag Filter System

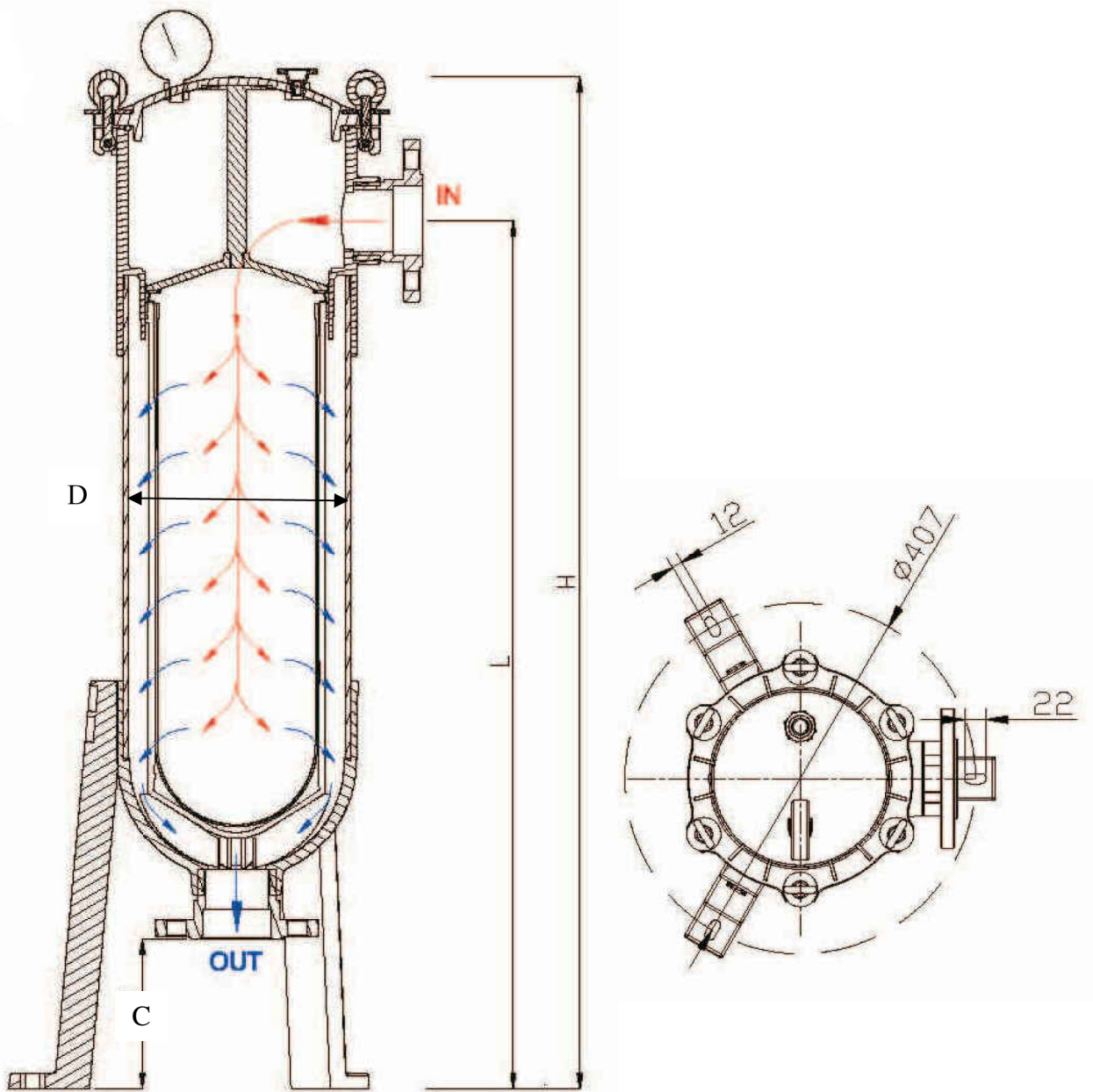

REF.	MODEL	C *	D *	H *	L *
FB355	HXP-BF-1-1-B	165	225	845	685
FB356	HXP-BF-1-2-B	165	225	1225	1065

* Dimensions are in mm.

Poliphosphate Proportioning Feeders



- proportional dosage to water flow through Venturi system;
- neutralizes the precipitation of calcium and magnesium carbonate up to 70°C making a protective coat over metallic share in contact with water;
- average dosage 3 ppm of P₂O₅;
- chrome plated brass head, trogamid sump;
- each feeder includes a polyphosphate package.
- IN-OUT connections 1/2" F;
- max operating pressure 10 bar;
- max operating temperature 40°C;
- flow rate 1.500 l/h;
- N.2 polyphosphate refills 80 g.

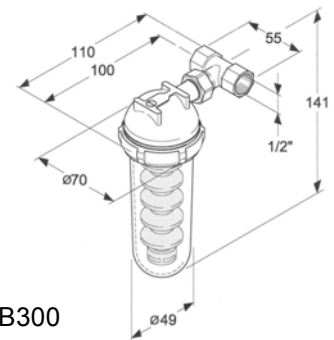

REF. FB300

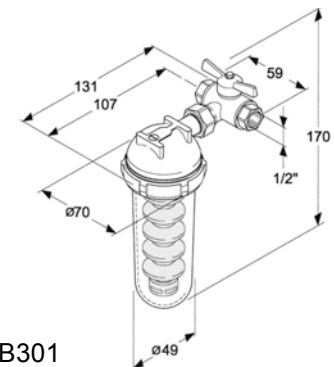

REF. FB301

REF.	MODEL	BY-PASS OPTION	
FB300	DP 12 OR	WITHOUT BY-PASS	
FB301	DP 12 OR BP	WITH BY-PASS	

- max operating pressure 10 bar;
- max operating temperature 40°C;
- N.2 polyphosphate refills 400 g.

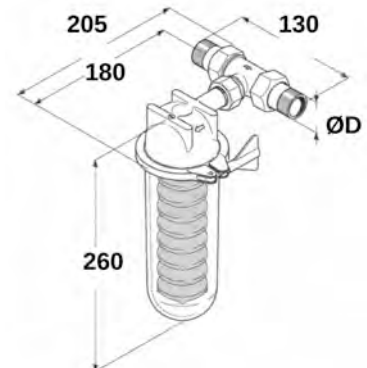

REF.	MODEL	IN-OUT CONNECTIONS	FLOW (l/h)	
FB302	DP 34 OR	3/4" M	2500	
FB303	DP 1 OR	1" M	3500	
FB304	DP 114 OR	1 1/4" M	4400	

Available polyphosphate packages as spare.

NOTE: PF/H type for hard water (> 15°F)

PF/S type for soft or softened (3 ÷ 15° F)

REF.	DESCRIPTION	PACKAGE (g)	
FB340	Polyphosphate PF/H for hard water	160	
FB341	Polyphosphate PF/H for hard water	400	
FB342	Polyphosphate PF/H for hard water	1000	
FB343	Polyphosphate PF/S for soft or softened	160	
FB344	Polyphosphate PF/S for soft or softened	400	
FB345	Polyphosphate PF/S for soft or softened	1000	

Polyphosphate Crystals Feeder



- polyphosphate crystals feeder antiscaling;
- particular suitable for washing machines – dish washers – boilers;
- initial filling of polyphosphate included;
- max operating pressure 7 bar;
- max operating temperature 45°C.

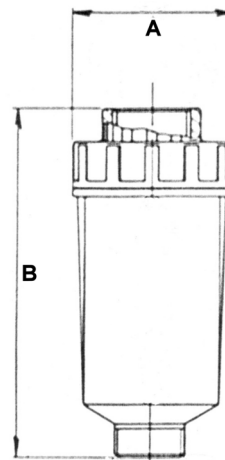

REF.	CONNECTIONS (inch)	A (mm)	B (mm)	POLYPHOSPHATE FILLING (g)	
FB308	3/4"	55	125	130	

Polyphosphate Crystals

- based on a mixture of selected high polymerization metaphosphates, in transparent vitreous state white colour;
- typical composition: $P_2O_5 > 60\%$ and $Na_2O = 30\%$ av.;
- to be used as antiscaling and corrosion inhibitor with water for potable and industrial applications;
- slow dissolution crystals, proportional to crystal size, temperature, pH and water hardness.

REF.	DIMENSIONS (mm)	PACKAGE (kg)	
FB350	5 ÷ 15	25	
FB351	10 ÷ 20	25	

Polyphosphate Feeders with Cartridges



- Particular suitable for washing machines – dish washers – boilers;
- Chrome plated brass head (item 3 and 4);
- IN/OUT connections 1/2”;
- Grilamid sump (item 6);
- Supplied with the first charge of polyphosphate (170 g);
- Operating flow rate 1200 l/h;
- Max operating temperature= 20°C;
- Max operating pressure = 16 bar;
- Test pressure = 50 bar;
- Empty weight 1.2 kg;
- Conform with the Italian DM25/2012 and DM174/2004;
- The presence of silicate ensures greater protection of metal parts against corrosion;
- The spherical shape of the polyphosphate in our FB701 allows a greater regularity of the product consumption and consequently a more regular dosage.

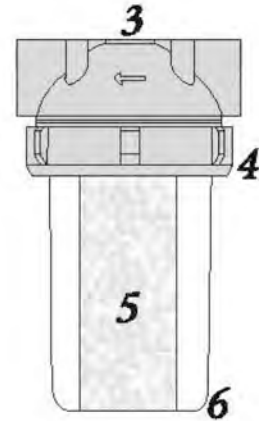

REF.	MODEL	
FB700 (*)	DP 12 WITH CARTRIDGE	
FB701 (*)	DP 12 SPHERICAL WITH CARTRIDGE	

(*) not available in stock.

Spare Parts

ITEM	REF.	DESCRIPTION	
5	FB730 (*)	CARTRIDGE FOR FB700	
5	FB731 (*)	CARTRIDGE FOR FB701	

Polyphosphate Feeders with Cartridges



- Particular suitable for washing machines – dish washers – boilers;
- Chrome plated brass head (item 1 and 4), Grilamid sump (item 5);
- 1/2" inlet and 1/2" outlet can be either vertical or horizontal connection: a kit provides a reduction from 3/4" to 1/2";
- Supplied with the first charge of polyphosphate (item 3);
- Operating flow rate 1200 l/h;
- Max operating temperature = 40°C;
- Max operating pressure = 10 bar, Test pressure = 30 bar;
- Empty weight 700 g;
- Conform with the Italian DM25/2012 and DM174/2004;
- Available on demand a wrench (our ref. FB317) to facilitate the disassembly of the housing.

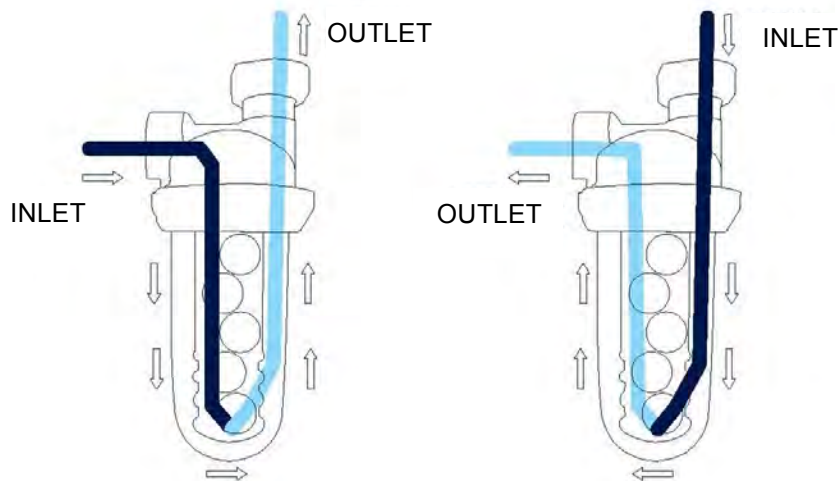

REF.	MODEL	
FB702 (*)	DP 12 34 WITH CARTRIDGE	

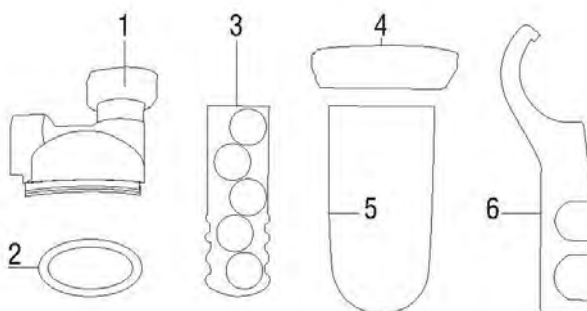

(*) not available in stock.

Spare Parts and Accessories

ITEM	REF.	DESCRIPTION	
3	FB732 (*)	N.2 CARTRIDGES FOR FB702	
6	FB317 (*)	WRENCH DP 12	



Ion exchange resins and filtering media



Pure Resin PC002



- Gel Strong Acid Cation Exchange Resin;
- light coloured;
- gel type sulfonated polystyrene cation resin supplied in the sodium form as moist, tough uniform spherical beads.
- well suited for industrial, commercial or residential softening applications where free chlorine is not present because of its high capacity and good physical stability.
- D.M. n.174 dated 06/04/2004 compliant about materials suitable for contact with water for human consumption;
- NSF/ANSI 44&61 certified.



Typical Physical & Chemical Characteristics	
Polymer Matrix Structure	Polystyrene crosslinked with 7% DVB
Functional Group	R-(SO ₃) ⁻ M ⁺
Ionic Form, as shipped	Sodium (Na ⁺)
Physical Form and Appearance	Clear Spherical Beads
Sphericity	95% min.
Screen Size Range --- U.S. Standard Screen	16 ÷ 50 mesh, wet
Particle Size Range	+1,2 mm < 5%, - 0,3 mm < 1%
Uniformity Coefficient	1,6 max.
Water Retention, Na ⁺ form	45 ÷ 50%
Swelling Na ⁺ → H ⁺ Ca ²⁺ → Na ⁺	10% max. 5% max.
Shipping Weight, Na ⁺ form	770 ÷ 870 g/l (50 lbs/cu.ft, approx.)
Total Exchange Capacity, Na ⁺ form	1,9 eq/l min.
pH Range	0 ÷ 14

REF.	
RA300	



Suggested Operating Conditions	
Maximum Temperature Na ⁺ form H ⁺ form	120°C (248°F) max. 100°C (212°F) max.
Minimum Bed Depth	0,6 m (24 inches)
Backwash Rate	25 ÷ 50% bed expansion
Regeneration Regenerant Concentration Flow Rate Contact Time	8 ÷ 20% NaCl or saturated salt water 2 ÷ 4 BV/h (0,25 ÷ 0,50 gpm/cu.ft) At least 30 Minutes
Displacement Rinse Rate	Same as Regenerant Flow Rate
Displacement Rinse Volume	1 ÷ 2 BV (7,5 ÷ 15 gallons/cu.ft)
Fast Rinse Rate	Same as Service Flow Rate
Fast Rinse Volume	3 ÷ 4 BV (22,5 ÷ 30 gallons/cu.ft)
Service Flow Rate	10 ÷ 50 BV/h (1,25 ÷ 6,25 gpm/cu.ft)
Hydraulic Properties	
<p style="text-align: center;">Pressure Drop</p> <p>Pressure Drop: The graph above shows the expected pressure loss per foot of bed depth as a function of flow rate at various temperatures.</p>	<p style="text-align: center;">Backwash Expansion</p> <p>Backwash: After each cycle the resin bed should be backwashed at a rate that expands the bed 25 to 50 percent. That will remove any foreign matter and reclassify the bed. The graph above shows the expansion characteristics of Pure PC002 in the sodium form.</p>

Pure Resin PC003



- Gel Strong Acid Cation Exchange Resin;
- high capacity premium grade bead form, conventional gel polystyrene sulphonate cation exchange resin supplied in the sodium or hydrogen form;
- intended for use in all water softening, dealcalisation, deionization and chemical processing applications, such as the following:
- in H form (PC003H), can be used in multiple and mixed bed demineralizers with strong base;
- anion exchangers such as Pure PA101, PA102 and PA103 in OH-form.
- well suited for industrial, commercial or residential softening applications because of its high capacity and good physical stability;
- D.M. n.174 dated 06/04/2004 compliant about materials suitable for contact with water for human consumption;
- NSF/ANSI 44&61 certified.



Typical Physical & Chemical Characteristics	
Polymer Matrix Structure	Polystyrene crosslinked with 8% DVB
Functional Group	R-(SO ₃)M ⁺
Ionic Form, as shipped	Na ⁺ / H ⁺
Physical Form and Appearance	Clear Spherical Beads
Sphericity	95% min.
Screen Size Range US Standard Screen	16 ÷ 50 mesh, wet
Particle Size Range	+1,2 mm < 5%, - 0,3 mm < 1%
Uniformity Coefficient	1,6 max.
Water Retention, Na ⁺ form H ⁺ form	43 ÷ 48% 50 ÷ 56%
Swelling Na ⁺ → H ⁺ Ca ²⁺ → Na ⁺	10% max. 5% max.
Shipping Weight, Na ⁺ form H ⁺ form	780 ÷ 880 g/l (51 lbs/cu.ft, approx.) 770 ÷ 870 g/l (50 lbs/cu.ft, approx.)
Total Exchange Capacity, Na ⁺ form H ⁺ form	2,0 eq/l min. 1,9 eq/l min.
pH Range	0 ÷ 14

REF.	
RA310	



Suggested Operating Conditions	
Maximum Temperature Na ⁺ form H ⁺ form	150°C (300°F) max. 100°C (212°F) max.
Minimum Bed Depth	0,6 m (24 inches)
Backwash Rate	25 ÷ 50% Bed Expansion
Regeneration Sodium Cycle Hydrogen Cycle Flow Rate	8 ÷ 20% NaCl 5 ÷ 10% HCl, 2-8% H ₂ SO ₄ 2 ÷ 7 BV/h (0,25 ÷ 0,90 gpm/cu.ft)
Displacement Rinse Rate	Same as Regenerant Flow Rate
Displacement Rinse Volume	1,4 ÷ 2,0 BV (10 ÷ 15 gallons/cu.ft)
Fast Rinse Rate	Same as Service Flow Rate
Fast Rinse Volume	4 ÷ 8 BV (30 ÷ 60 gallons/cu.ft)
Service Flow Rate	10 ÷ 50 BV/h (1,25 ÷ 6,25 gpm/cu.ft)

Hydraulic Properties

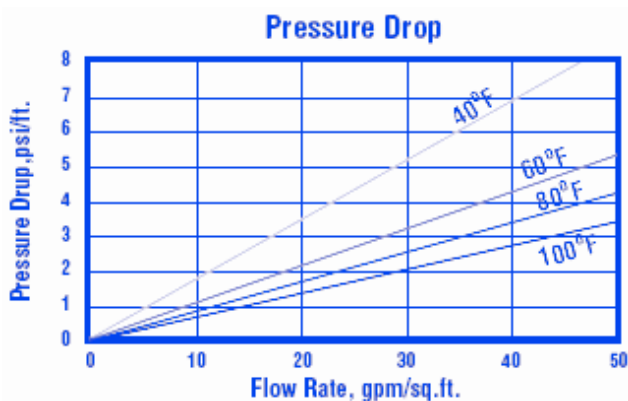

Pressure Drop: The graph above shows the expected pressure loss per foot of bed depth as a function of flow rate at various Temperatures.

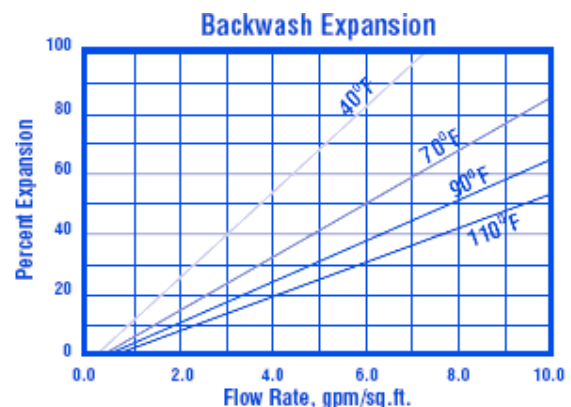

Backwash: After each cycle the resin bed should be backwashed at a rate that expands the bed 25 to 50 percent. That will remove any foreign matter and reclassify the bed. The graph above shows the expansion characteristics of Pure PC003 in the sodium form.

Pure Resin PC003 UN-NA



- Gel Strong Acid Cation Exchange Resin with high uniformity coefficient;
- high capacity premium grade bead form, conventional gel polystyrene sulphonate cation exchange resin supplied in the sodium or hydrogen form;
- intended for use in all water softening, dealcalisation, deionization and chemical processing applications, such as the following:
- in H form (PC003HUN), can be used in multiple and mixed bed demineralizers with strong base;
- anion exchangers such as Pure PA101, PA102 and PA103 in OH-form.
- well suited for industrial, commercial or residential softening applications because of its high capacity and good physical stability;
- D.M. n.174 dated 06/04/2004 compliant about materials suitable for contact with water for human consumption;
- NSF/ANSI 44&61 certified.



Typical Physical & Chemical Characteristics	
Polymer Matrix Structure	Polystyrene crosslinked with 8% DVB
Functional Group	R-(SO ₃)M ⁺
Ionic Form, as shipped	Na ⁺
Physical Form and Appearance	Clear Spherical Beads
Sphericity	95% min.
Screen Size Range US Standard Screen	25 ÷ 35 mesh, wet
Particle Size Range	0,5 ÷ 0,71 mm ≥ 95%
Uniformity Coefficient	1,15 max.
Water Retention, Na ⁺ form H ⁺ form	43 ÷ 48% 47 ÷ 54%
Swelling Na ⁺ → H ⁺ Ca ²⁺ → Na ⁺	10% max. 5% max.
Shipping Weight, Na ⁺ form H ⁺ form	780 ÷ 880 g/l (51 lbs/cu.ft, approx.) 770 ÷ 870 g/l (50 lbs/cu.ft, approx.)
Total Exchange Capacity, Na ⁺ form H ⁺ form	2,0 eq/l min. 1,9 eq/l min.
pH Range	0 ÷ 14

REF.	
RA312	



Suggested Operating Conditions	
Maximum Temperature Na ⁺ form H ⁺ form	150°C (300°F) max. 100°C (212°F) max.
Minimum Bed Depth	0,6 m (24 inches)
Backwash Rate	25 ÷ 50% Bed Expansion
Regeneration Sodium Cycle Hydrogen Cycle Flow Rate	8 ÷ 20% NaCl 5 ÷ 10% HCl, 2-8% H ₂ SO ₄ 2 ÷ 7 BV/h (0,25 ÷ 0,90 gpm/cu.ft)
Displacement Rinse Rate	Same as Regenerant Flow Rate
Displacement Rinse Volume	1,4 ÷ 2,0 BV (10 ÷ 15 gallons/cu.ft)
Fast Rinse Rate	Same as Service Flow Rate
Fast Rinse Volume	4 ÷ 8 BV (30 ÷ 60 gallons/cu.ft)
Service Flow Rate	10 ÷ 50 BV/h (1,25 ÷ 6,25 gpm/cu.ft)
Hydraulic Properties	
<p>(*) = m of water / m of bed</p>	<p>Backwash: After each cycle the resin bed should be backwashed at a rate that expands the bed 25 to 50 percent. That will remove any foreign matter and reclassify the bed. The graph above shows the expansion characteristics of Pure PC003UN in the sodium form.</p>

Pure Resin PC003 IND-2



- Gel Strong Acid Cation Exchange Resin, with high purity premium grade bead form, high capacity;
- Conventional gel polystyrene sulphonate cation exchange resin supplied in the hydrogen form;
- It can be well used in multiple and mixed bed demineralizers to inform customer when the resin is exhausted or not.



Typical Physical & Chemical Characteristics	
Polymer Matrix Structure	Polystyrene crosslinked with DVB
Functional Group	R-(SO ₃) ⁻ M ⁺ (color : Violet → Yellow)
Ionic Form, as shipped	Na ⁺ / H ⁺
Physical Form and Appearance	Clear Spherical Beads
Sphericity	95% min.
Screen Size Range US Standard Screen	16 ÷ 50 mesh, wet
Particle Size Range	+1,2 mm < 5%, - 0,3 mm < 1%
Uniformity Coefficient	1,6 max.
Water Retention, Na ⁺ form H ⁺ form	43 ÷ 48% 47 ÷ 54%
Swelling Na ⁺ → H ⁺ Ca ²⁺ → Na ⁺	10% max. 5% max.
Shipping Weight, Na ⁺ form H ⁺ form	780 ÷ 880 g/l (51 lbs/cu.ft, approx.) 770 ÷ 870 g/l (50 lbs/cu.ft, approx.)
Total Exchange Capacity, Na ⁺ form H ⁺ form	2,0 eq/l min. 1,9 eq/l min.
pH Range	0 ÷ 14

REF.	
RA316	



Suggested Operating Conditions	
Maximum Temperature Na ⁺ form H ⁺ form	120°C (248°F) max. 100°C (212°F) max.
Minimum Bed Depth	0,6 m (24 inches)
Backwash Rate	25 ÷ 50% Bed Expansion
Regeneration Sodium Cycle Hydrogen Cycle Flow Rate	10 ÷ 15% NaCl 10% HCl, 1-8% H ₂ SO ₄ 2 ÷ 7 BV/h (0,25 ÷ 0,90 gpm/cu.ft)
Displacement Rinse Rate	Same as Regenerant Flow Rate
Displacement Rinse Volume	1,4 ÷ 2,0 BV (10 ÷ 15 gallons/cu.ft)
Fast Rinse Rate	8 ÷ 40 BV/h (1 ÷ 5 gpm/cu.ft)
Fast Rinse Volume	3 ÷ 10 BV (22,5 ÷ 75 gallons/cu.ft)
Service Flow Rate	4 ÷ 8 BV/h (0,5 ÷ 1 gpm/cu.ft)

Hydraulic Properties

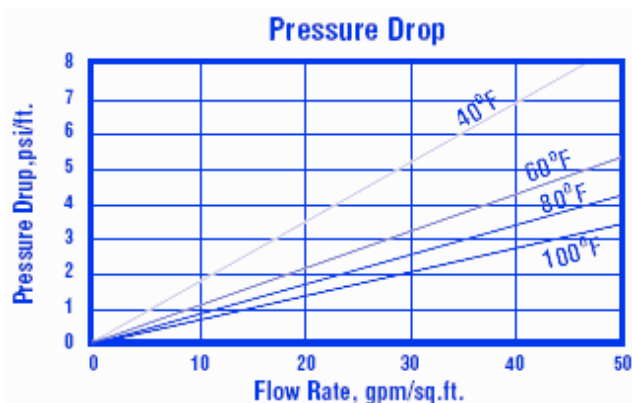

Pressure Drop: The graph above shows the expected pressure loss per foot of bed depth as a function of flow rate at various Temperatures.

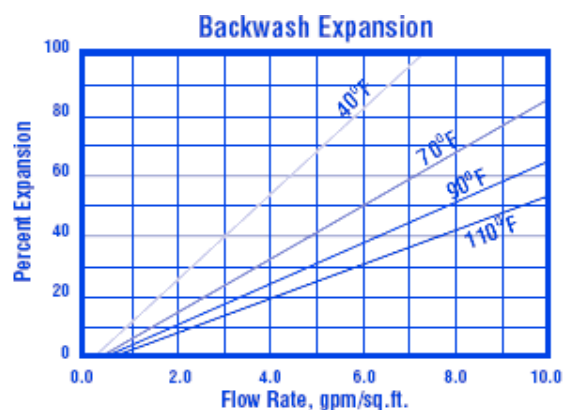

Backwash: After each cycle the resin bed should be backwashed at a rate that expands the bed 25 to 50 percent. That will remove any foreign matter and reclassify the bed. The graph above shows the expansion characteristics of Pure PC003 IND-2.

Pure Resin PC100NA



- Macroporous Strong Acid Cation Exchange Resin;
- macroporous poly (styrene sulphonate) cation exchange resin with excellent resistance to both osmotic and thermal shock;
- supplied as spherical beads;
- used for water softening with high level of DVB;
- also widely used in mixed bed demineralizers where high hydraulic demands exist and high resistance to mechanical thermal and oxidative stresses are required, such as condensate polishing, chemical processing, hydrometallurgy, sugar treatment.



Typical Physical & Chemical Characteristics	
Polymer Matrix Structure	Polystyrene crosslinked with 8% DVB
Functional Group	R-(SO ₃) ⁻ M ⁺
Ionic Form, as shipped	Na ⁺
Physical Form and Appearance	Clear Spherical Beads
Sphericity	95% min.
Screen Size Range US Standard Screen	16 ÷ 50 mesh, wet
Particle Size Range	+1,2 mm < 5%, - 0,3 mm < 1%
Uniformity Coefficient	1,6 max.
Water Retention	45 ÷ 55%
Swelling Na ⁺ → H ⁺	10% max.
Shipping Weight	760 ÷ 830 g/l (50 lbs/cu.ft, approx.)
Total Exchange Capacity	1,8 eq/l min.
pH Range	0 ÷ 14

REF.	
RA318	



Suggested Operating Conditions

Maximum Temperature	150°C (300°F) max.
Minimum Bed Depth	0,6 m (24 inches)
Backwash Rate	25 ÷ 50% Bed Expansion
Regeneration Flow Rate Contact Time	8 ÷ 20% NaCl 2 ÷ 7 BV/h (0,25 ÷ 0,90 gpm/cu.ft) At least 20 Minutes
Displacement Rinse Rate	Same as Regenerant Flow Rate
Displacement Rinse Volume	1,4 ÷ 2,0 BV (10 ÷ 15 gallons/cu.ft)
Fast Rinse Rate	Same as Service Flow Rate
Fast Rinse Volume	4 ÷ 8 BV (30 ÷ 60 gallons/cu.ft)
Service Flow Rate	10 ÷ 50 BV/h (1,25 ÷ 6,25 gpm/cu.ft)

Hydraulic Properties

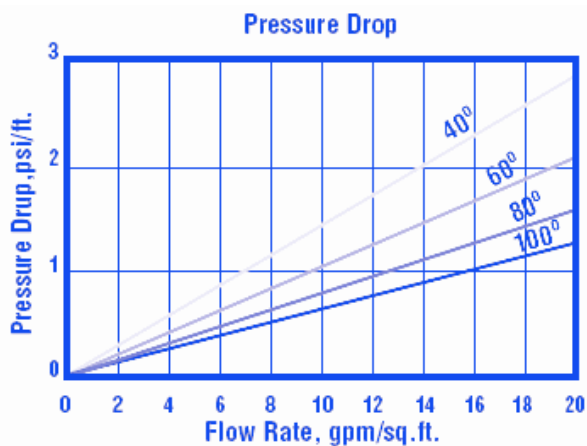

Pressure Drop: The graph above shows the expected pressure loss per foot of bed depth as a function of flow rate at various temperatures.

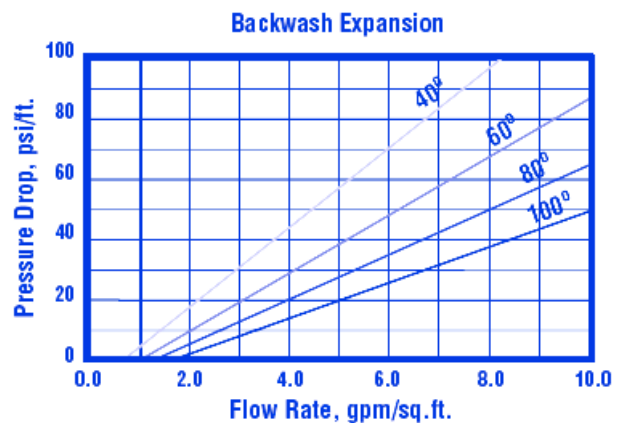

Backwash: After each cycle the resin bed should be backwashed at a rate that expands the bed 25 to 50 percent. That will remove any foreign matter and reclassify the bed. The graph above shows the expansion characteristics of Pure PC100.

Pure Resin PC100H



- Macroporous Strong Acid Cation Exchange Resin;
- macroporous poly (styrene sulphonate) cation exchange resin with excellent resistance to both osmotic and thermal shock;
- supplied as spherical beads;
- used for water softening with high level of DVB;
- also widely used in mixed bed demineralizers where high hydraulic demands exist and high resistance to mechanical thermal and oxidative stresses are required, such as condensate polishing, chemical processing, hydrometallurgy, sugar treatment.



Typical Physical & Chemical Characteristics	
Polymer Matrix Structure	Polystyrene crosslinked with 8% DVB
Functional Group	R-(SO ₃) ⁻ M ⁺
Ionic Form, as shipped	H ⁺
Physical Form and Appearance	Clear Spherical Beads
Sphericity	95% min.
Screen Size Range US Standard Screen	16 ÷ 50 mesh, wet
Particle Size Range	+1,2 mm < 5%, - 0,3 mm < 1%
Uniformity Coefficient	1,6 max.
Water Retention	50 ÷ 60%
Swelling Na ⁺ → H ⁺	10% max.
Shipping Weight, Na ⁺ form	760 ÷ 830 g/l (50 lbs/cu.ft, approx.)
Total Exchange Capacity	1,7 eq/l min.
pH Range	0 ÷ 14
REF.	
RA320	



Suggested Operating Conditions

Maximum Temperature	120°C (248°F) max.
Minimum Bed Depth	0,6 m (24 inches)
Backwash Rate	25 ÷ 50% Bed Expansion
Regeneration Flow Rate Contact Time	5 ÷ 10% HCl, 2 ÷ 8% H ₂ SO ₄ 2 ÷ 7 BV/h (0,25 ÷ 0,90 gpm/cu.ft) At least 20 Minutes
Displacement Rinse Rate	Same as Regenerant Flow Rate
Displacement Rinse Volume	1,4 ÷ 2,0 BV (10 ÷ 15 gallons/cu.ft)
Fast Rinse Rate	Same as Service Flow Rate
Fast Rinse Volume	4 ÷ 8 BV (30 ÷ 60 gallons/cu.ft)
Service Flow Rate	10 ÷ 50 BV/h (1,25 ÷ 6,25 gpm/cu.ft)

Hydraulic Properties

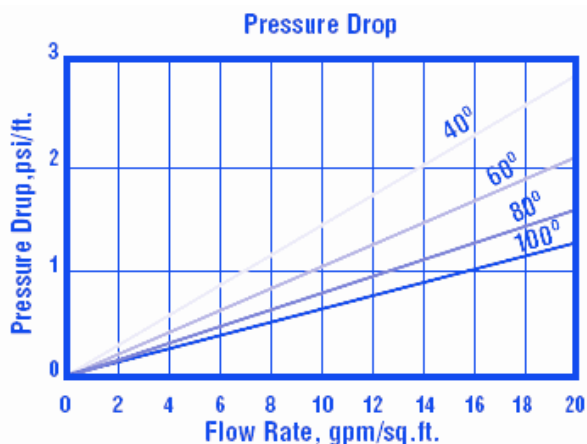

Pressure Drop: The graph above shows the expected pressure loss per foot of bed depth as a function of flow rate at various temperatures.

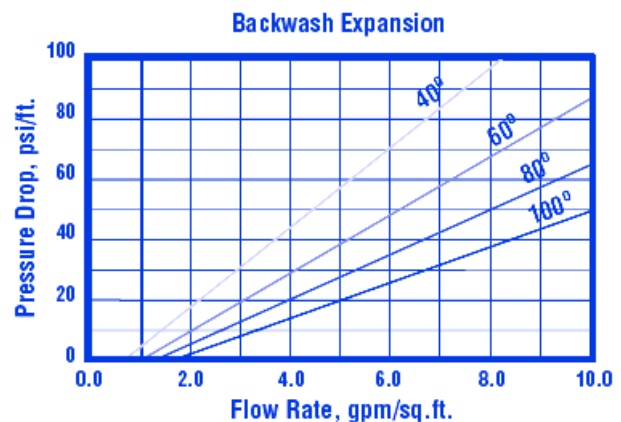

Backwash: After each cycle the resin bed should be backwashed at a rate that expands the bed 25 to 50 percent. That will remove any foreign matter and reclassify the bed. The graph above shows the expansion characteristics of Pure PC100.

Pure Resin PC200FD



- Macroporous Weak Acid Cation Exchange Resin;
- macroporous poly-acrylic weak acid cation resin;
- it can be supplied in the hydrogen (H⁺) form or sodium (Na⁺) as spherical beads;
- in H cycle is used for dealcalisation, deionization and chemical processing applications;
- supplied in sodium cycle for use in applications such as softening and heavy metal cations removal. This requires a two stage regeneration process using a strong acid first and then a neutralization rinse to put the resin into the sodium form and is especially effective in high solids softening applications.



Typical Physical & Chemical Characteristics	
Polymer Matrix Structure	Acrylic-Divinylbenzene
Functional Group	R-(COOH) ⁻
Ionic Form, as shipped	H ⁺
Physical Form and Appearance	Clear Spherical Beads
Sphericity	95% min.
Screen Size Range US Standard Screen	16 ÷ 50 mesh, wet
Particle Size Range	+1,2 mm < 5%, - 0,3 mm < 1%
Uniformity Coefficient	1,6 max.
Water Retention, H ⁺ form	50 ÷ 60%
Swelling Na ⁺ → H ⁺	65% max.
Shipping Weight, H ⁺ form	700 ÷ 780 g/l (45 lbs/cu.ft, approx.)
Total Exchange Capacity, H ⁺ form	3,5 eq/l min.
pH Range	4 ÷ 14

REF.	
RA330	



Suggested Operating Conditions

Maximum Temperature, H ⁺ form	120°C (248°F) max.
Minimum Bed Depth	0,8 m (30 inches)
Backwash Rate	25 ÷ 50% Bed Expansion
Regeneration, Hydrogen Cycle Flow Rate Contact Time	5 ÷ 10% HCl, 0,5 ÷ 1% H ₂ SO ₄ 2 ÷ 7 BV/h 8 ÷ 20 BV/h At least 30 Minutes
Displacement Rinse Rate	Same as Regenerant Flow Rate
Displacement Rinse Volume	1,4 ÷ 2 BV (10 ÷ 15 gallons/cu.ft)
Fast Rinse Rate	Same as Service Flow Rate
Fast Rinse Volume	4 ÷ 8 BV (30 ÷ 60 gallons/cu.ft)
Service Flow Rate	10 ÷ 50 BV/h (1,25 ÷ 6,25 gpm/cu.ft)

Hydraulic Properties

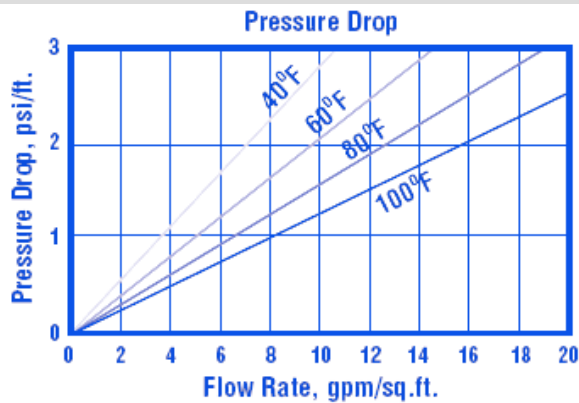

Pressure Drop: The graph above shows the expected pressure loss per foot of bed depth as a function of flow rate at various temperatures.

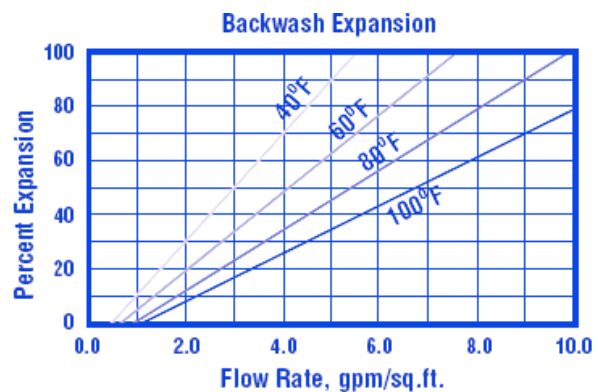

Backwash: After each cycle the resin bed should be backwashed at a rate that expands the bed 25 to 50 percent. That will remove any foreign matter and reclassify the bed. The graph above shows the expansion characteristics of Pure PC200FD.

Pure Resin PA103OH



- REF. RA340;
- Gel Strong Base Anion Exchange Resin;
- it is a Type II, gel strong-base anion exchange resin, with high capacity and excellent regeneration efficiency;
- supplied as spherical beads in the hydroxyl form;
- it removes all ions including silica and CO₂, anyway, it operates best on waters having a high percentage of strong acids (FMA);
- Intended for use in all type of dealcalisation, demineralization, deionization and chemical processing applications.



Typical Physical & Chemical Characteristics	
Polymer Matrix Structure	Polystyrene crosslinked with divinylbenzene
Functional Group	R-N(CH ₃) ₂ (C ₂ O ₄ H) ⁺
Ionic Form, as shipped	Hydroxyl (OH ⁻)
Physical Form and Appearance	Clear Spherical Beads
Sphericity	95% min.
Screen Size Range US Standard Screen	16 ÷ 50 mesh, wet
Particle Size Range	+1,2 mm < 5%, - 0,3 mm < 1%
Uniformity Coefficient	1,6 max.
Water Retention, Cl ⁻ form	45 ÷ 51%
Swelling Cl ⁻ → OH ⁻	15% max.
Weight, Cl ⁻ form	680 ÷ 760 g/l (44 lbs/cu.ft, approx.)
Total Exchange Capacity, Cl ⁻ form	1,3 eq/l min.
pH Range	0 ÷ 14

REF.	
RA340	



Suggested Operating Conditions	
Maximum Temperature, Cl ⁻ form OH ⁻ form	60°C (140°F) max. 40°C (105°F) max.
Minimum Bed Depth	0,6 m (24 inches)
Backwash Rate	50 ÷ 75% Bed Expansion
Regeneration, Regenerant Concentration Flow Rate Contact Time	2 ÷ 6% NaOH 2 ÷ 4 BV/h (0,25 ÷ 0,50 gpm/cu.ft) At least 60 Minutes
Displacement Rinse Rate	Same as Regenerant Flow Rate
Displacement Rinse Volume	1,4 ÷ 2 BV (10 ÷ 15 gallons/cu.ft)
Fast Rinse Rate	Same as Service Flow Rate
Fast Rinse Volume	4 ÷ 8 BV (30 ÷ 60 gallons/cu.ft)
Service Flow Rate	10 ÷ 50 BV/h (1,25 ÷ 6,25 gpm/cu.ft)
Hydraulic Properties	
<p style="text-align: center;">Pressure Drop</p> <p>Pressure Drop: The graph above shows the expected pressure loss per foot of bed depth as a function of flow rate at various temperatures.</p>	<p style="text-align: center;">Backwash Expansion</p> <p>Backwash: After each cycle the resin bed should be backwashed at a rate that expands the bed 50 to 75 percent. That will remove any foreign matter and reclassify the bed. The graph above shows the expansion characteristics of Pure PA103.</p>

Pure Resin PA101 IND-1



- Gel Strong Base Anion Exchange Resin;
- It is a Type I, gel strong-base anion exchange resin with both high operating capacity and the ability to achieve low residual silica levels;
- Supplied as spherical beads in the hydroxyl form;
- It can be well used in multiple and mixed bed demineralizers to inform customer when the resin is exhausted or not.



Typical Physical & Chemical Characteristics	
Polymer Matrix Structure	Polystyrene crosslinked with divinylbenzene
Functional Group	R-N(CH ₃) ₃ ⁺ (color : Blue → Yellow)
Ionic Form, as shipped	Hydroxyl (OH ⁻)
Physical Form and Appearance	Clear Spherical Beads
Sphericity	95% min.
Screen Size Range US Standard Screen	16 ÷ 50 mesh, wet
Particle Size Range	+1,2 mm < 5%, - 0,3 mm < 1%
Uniformity Coefficient	1,6 max.
Water Retention, Cl ⁻ form	55 ÷ 65%
Swelling Cl ⁻ → OH ⁻	20 ÷ 30%
Weight, Cl ⁻ form	660 ÷ 710 g/l (43 lbs/cu.ft, approx.)
Total Exchange Capacity, Cl ⁻ form	1,0 eq/l min.
pH Range	0 ÷ 14

REF.	
RA338	



Suggested Operating Conditions	
Maximum Temperature, Cl ⁻ form OH ⁻ form	100°C (212°F) max. 60°C (140°F) max.
Minimum Bed Depth	0,6 m (24 inches)
Backwash Rate	50 ÷ 75% Bed Expansion
Regeneration, Regenerant Concentration Flow Rate Contact Time	2 ÷ 6% NaOH 2 ÷ 8 BV/h (0,25 ÷ 1,00 gpm/cu.ft) At least 60 Minutes
Displacement Rinse Rate	Same as Regenerant Flow Rate
Displacement Rinse Volume	1,4 ÷ 2 BV (10 ÷ 15 gallons/cu.ft)
Fast Rinse Rate	Same as Service Flow Rate
Fast Rinse Volume	4,9 ÷ 8 BV (35 ÷ 60 gallons/cu.ft)
Service Flow Rate	4 ÷ 8 BV/h (0,5 ÷ 1,0 gpm/cu.ft)

Hydraulic Properties

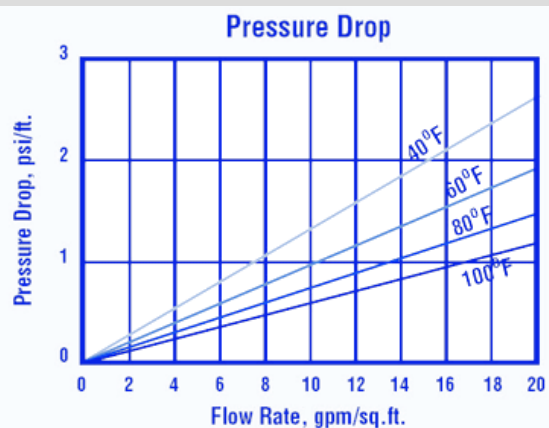

Pressure Drop: The graph above shows the expected pressure loss per foot of bed depth as a function of flow rate at various temperatures.

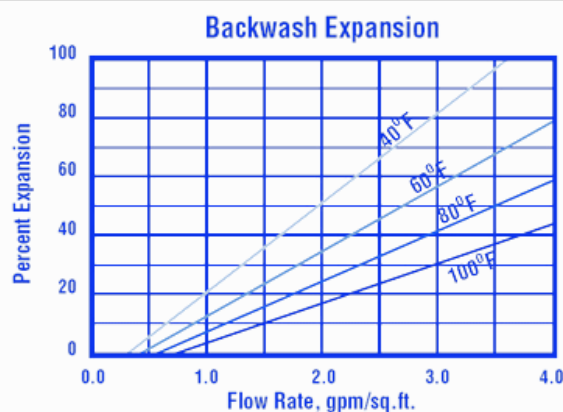

Backwash: After each cycle the resin bed should be backwashed at a rate that expands the bed 50 to 75 percent. That will remove any foreign matter and reclassify the bed. The graph above shows the expansion characteristics of Pure PA101 IND-1.

Pure Resin PA201(CL)



- Macroporous Strong Base Anion Exchange Resin;
- it is a Type II, gel strong-base anion exchange resin;
- supplied wet as spherical beads in the chloride form;
- it has a high operating capacity, especially on high-FMA feedwaters, as well as a high reversible sorptive capacity for complex organic materials, such as the fulvic and humic acids which occur in many surface water supplies;
- it is recommended for use in waters with low silica loads. For high silica waters, a type I anion resin such as Pure PA200 is recommended.



Typical Physical & Chemical Characteristics	
Polymer Matrix Structure	Macroporous polystyrene crosslinked with divinylbenzene
Functional Group	R-N(CH ₃) ₂ (C ₂ H ₄ OH) ⁺
Ionic Form, as shipped	Chloride (Cl ⁻)
Physical Form and Appearance	Opaque light yellowish spherical beads
Sphericity	95% min.
Screen Size Range US Standard Screen	16 ÷ 50 mesh, wet
Particle Size Range	+1,2 mm < 5%, - 0,3 mm < 1%
Uniformity Coefficient	1,6 max.
Water Retention, Cl ⁻ form	47 ÷ 57%
Swelling Cl ⁻ → OH ⁻	10% max.
Weight, Cl ⁻ form	660 ÷ 730 g/l (43 lbs/cu.ft, approx.)
Total Exchange Capacity, Cl ⁻ form	1,2 eq/l min.
pH Range	0 ÷ 14

REF.	
RA342	

Pure Resin PA201(CL)



Suggested Operating Conditions	
Maximum Temperature, Cl ⁻ form OH ⁻ form	60°C (140°F) max. 40°C (105°F) max.
Minimum Bed Depth	0,8 m (2,6 ft)
Backwash Rate	50 ÷ 75% Bed Expansion
Regeneration, Regenerant Concentration	2 ÷ 5% NaOH
Service/fast rinse	5 ÷ 50 m/h (2 ÷ 20 gpm/ft ²)
Co-current regeneration/displacement rinse	1 ÷ 10 m/h (0,4 ÷ 4 gpm/ft ²)
Total rinse requirement	3 ÷ 5 Bed volumes
Temperature	Ambient up to 35°C (95°F) for silica removal



- It is a Type I, Macroporous Strong Base Anion Exchange Resin supplied in chloride or hydroxide and has high capacity, shock resistant with high physical stability;
- It is widely used in multiple and mixed bed demineralizers, wherever complete ion and organic removal are required;
- It is also intended for use in all types of deionization systems, condensate polishing and chemical processing applications.



Typical Physical & Chemical Characteristics	
Polymer Matrix Structure	Macroporous polystyrene crosslinked with divinylbenzene
Functional Group	R-N(CH ₃) ₃ + X
Ionic Form, as shipped	Chloride (Cl ⁻)
Physical Form and Appearance	Opaque light yellowish spherical beads
Sphericity	95% min.
Screen Size Range US Standard Screen	16 ÷ 50 mesh, wet
Particle Size Range	+1,2 mm < 5%, - 0,3 mm < 1%
Uniformity Coefficient	1,6 max.
Water Retention, Cl ⁻ form	50 ÷ 60%
Swelling Cl ⁻ → OH ⁻	20 ÷ 30%
Weight, Cl ⁻ form	660 ÷ 730 g/l (43 lbs/cu.ft, approx.)
Total Exchange Capacity, Cl ⁻ form	1,15 eq/l min.
Total Exchange Capacity, OH ⁻ form	0,92 eq/l min.
pH Range	0 ÷ 14

REF.	
RA341	



Suggested Operating Conditions	
Maximum Temperature, Cl ⁻ form OH ⁻ form	80°C (170°F) max. 60°C (140°F) max.
Minimum Bed Depth	0,6 m (24")
Backwash Rate	50 ÷ 75% Bed Expansion
Regeneration, Regenerant Concentration	4 ÷ 6% NaOH
Service/Fast Rinse	2 ÷ 8 BV/h (0,25 ÷ 1,0 gpm/ft ²)
Contact Time	Minimum 60 minutes
Displacement Rinse Rate	Same as Regenerant Flow Rate
Displacement Rinse Volume	1,4 ÷ 2,0 BV (10 ÷ 15 gallons/cu.ft)
Fast Rinse Rate	Same as Service Flow Rate
Fast Rinse Volume	4,6 ÷ 8 BV (35 ÷ 60 gallons/cu.ft)
Service Flow Rate	16 ÷ 32 BV/h (2,0 ÷ 4,0 gpm/cu.ft)
Hydraulic Properties	
<p>Pressure Drop: The graph above shows the expected pressure loss per foot of bed depth as a function of flow rate at various Temperatures.</p>	<p>Backwash: After each cycle the resin bed should be backwashed at a rate that expands the bed 50 to 75 percent. That will remove any foreign matter and reclassify the bed. The graph above shows the expansion characteristics of Pure PA200.</p>



- Macroporous Weak Base Anion Exchange Resin;
- it is a macroporous polystyrene weak-base anion exchange resin having tertiary amine functionality;
- it has superior kinetics and greater resistance to oxidation and osmotic shock, high chemical and physical stability;
- intended primarily for use in multiple bed demineralizers;
- it can be used in a two-bed system following a strong acid cation exchanger such as Pure PC003 where weak acid ions (silica and carbon dioxide) do not have to be removed;
- it can also be used in a separate bed, ahead of the strong base exchanger to remove organics and strong acid ions.



Typical Physical & Chemical Characteristics	
Polymer Matrix Structure	Macroporous Polystyrene with DVB
Functional Group	R-N-(CH ₃) ₂ ⁺
Ionic Form, as shipped	Free Base
Physical Form and Appearance	Spherical Beads
Sphericity	95% min.
Screen Size Range US Standard Screen	16 ÷ 50 mesh, wet
Particle Size Range	+1,2 mm < 5%, - 0,3 mm < 1%
Uniformity Coefficient	1,6 max.
Water Retention, Free Base	50 ÷ 60%
Swelling Na ⁺ → Cl ⁻	25% max.
Shipping Weight	650 ÷ 720 g/l (42 lbs/cu.ft, approx.)
Total Exchange Capacity, Free Base	1,4 eq/l min.
pH Range	0 ÷ 14

REF.	
RA350	



Suggested Operating Conditions	
Maximum Temperature Free Base	100°C (212°F) max.
Minimum Bed Depth	0,6 m (24 inches)
Backwash Expansion	50 ÷ 75%
Regeneration Regenerant Concentration Flow Rate Contact Time	2 ÷ 6% NaOH 2 ÷ 8 BV/h (0,25 ÷ 1,0 gpm/cu.ft) At least 60 Minutes
Displacement Rinse Rate	Same as Regenerant Flow Rate
Displacement Rinse Volume	1,4 ÷ 2 BV (10 ÷ 15 gallons/cu.ft)
Fast Rinse Rate	Same as Service Flow Rate
Fast Rinse Volume	4,9 ÷ 8 BV (35 ÷ 60 gallons/cu.ft)
Service Flow Rate	16 ÷ 32 BV/h (2,0 ÷ 4,0 gpm/cu.ft)

Hydraulic Properties

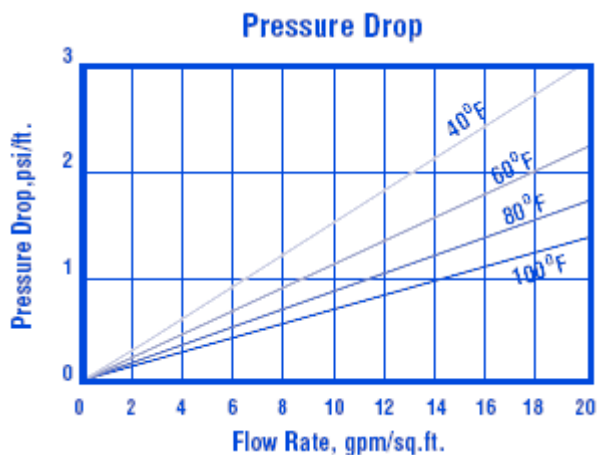

Pressure Drop: The graph above shows the expected pressure loss per foot of bed depth as a function of flow rate at various temperatures.

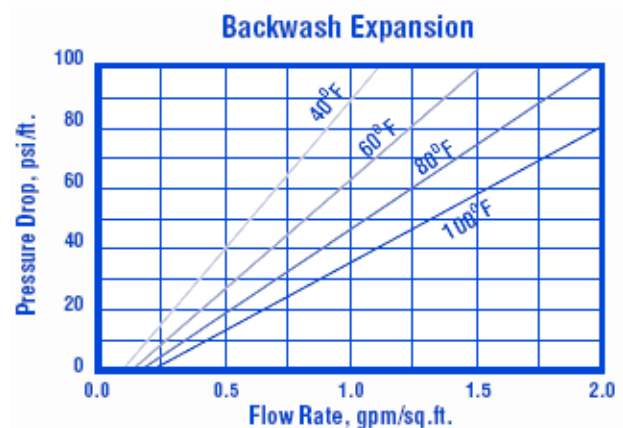

Backwash: After each cycle the resin bed should be backwashed at a rate that expands the bed 50 to 75 percent. That will remove any foreign matter and reclassify the bed. The graph above shows the expansion characteristics of Pure PA300.

Pure Resin PA202



- Nitrate Selective Resin;
- macroporous strong base anion exchange resin supplied in the chloride form as moist, tough, spherical beads, specially designed for the removal of nitrates from water for potable processes;
- the macroporous matrix and special ion exchange group functionality imparts ideal nitrate selectivity to Pure PA202 making this resin particularly suitable for nitrate removal even when moderate to high sulphate concentrations are present.



Typical Physical & Chemical Characteristics	
Polymer Matrix Structure	Macroporous, Styrene with DVB
Functional Group	R-N-R ₃ ⁺ Cl ⁻
Ionic Form, as shipped	Cl ⁻
Physical Form and Appearance	Clear Spherical Beads
Sphericity	95% min.
Screen Size Range US Standard Screen	16 ÷ 50 mesh, wet
Particle Size Range	+1,2 mm < 5%, - 0,3 mm < 1%
Uniformity Coefficient	1,6 max.
Water Retention, Cl ⁻ form	52 ÷ 56%
Shipping Weight	680 ÷ 730 g/l (42 ÷ 45,5 lbs/cu.ft, approx.)
Total Exchange Capacity	1,0 eq/l min.
Max Operating Temperature	100°C (212°F) max.
pH Range	0 ÷ 14

REF.	
RA360	



Suggested Operating Conditions	
Maximum Operating Temperature	100°C (212°F) max.
Working Exchange Capacity @ 25°C	≥ 0,3 meq/l (wet)
Concentration of Regenerate Solution	NaCl: 8 ÷ 10%
Consumption of Regenerate	NaCl (8 ÷ 10%) Vol. : Resin Vol. = 2÷3 : 1
Flow Rate of Regenerate Solution	4 ÷ 6 (m/hr)
Regenerate Contact time	30 ÷ 60 (minute)
Rinse Flow Rate	15 ÷ 25 (m/hr)
Rinse Time (minute)	25 (approx.)
Operating Flow Rate	15 ÷ 25(m/hr)

Pure Resin PMB101-2



- Mixed Bed Resin;
- it is a high capacity mixed bed ion exchange resin consisting of a mixture of a gel, Type I strong base anion resin and a gel strong acid cation resin for direct water purification;
- the conductivity is around 0,1 us/cm;
- suitable for use in regenerable or non-regenerable cartridges, for deionization with high silica removal efficiency and refine water for electrical home applications.



Typical Physical & Chemical Characteristics	
Polymer Matrix Structure	Gel polystyrene crosslinked with DVB
Functional Group: Cation Anion	R-SO ₃ ⁻ H ⁺ R ₄ -N-OH ⁻
Ionic Form, as shipped	H ⁺ / OH ⁻
Physical Form and Appearance	Spherical Beads
Sphericity	95% min.
Screen Size Range US Standard Screen	16 ÷ 50 mesh, wet
Particle Size Range	+1,2 mm < 5%, - 0,3 mm < 1%
Volume Ratio (as shipped) Cation Anion	40% PC003H 60% PA1010H
Total Exchange Capacity, Cation (in Na ⁺ form) Cation (in H ⁺ form) Anion (in Cl ⁻ form) Anion (in OH ⁻ form)	2,0 eq/l min. 1,9 eq/l min. 1,3 eq/l min. 1,0 eq/l min.
Water Retention, H ⁺ form OH ⁻ form	45 ÷ 50% 53 ÷ 60%
Shipping Weight (Approx.)	700 ÷ 740 g/l (44 ÷ 46 lbs/cu.ft, approx.)
Max temperature: Non-regenerative bed Regenerative bed	100°C (212°F) 60°C (140°F)
pH Range	0 ÷ 14
REF.	
RA370	



Suggested Operating Conditions

Minimum Bed Depth	0,6 m (24 inches)
Service Flow Rate	20 ÷ 60 BV/h (2,5 ÷ 7,5 gpm/cu.ft)
Limitations	Extended exposure to strong oxidizers, such as chlorine, hydrogen peroxide and concentrated nitric acid, degrade the structural backbone of the resin and should be avoided

Hydraulic Properties

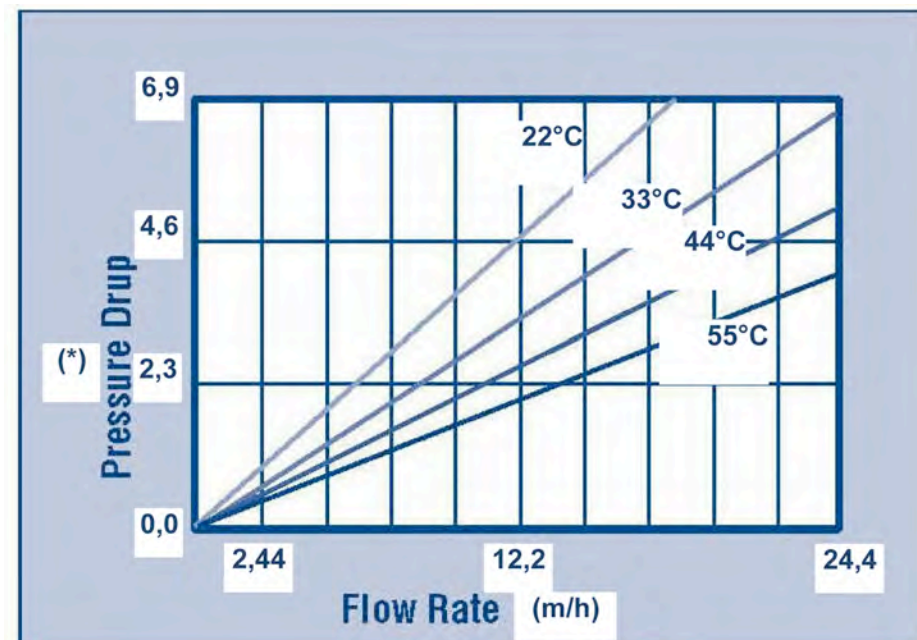

(*) = m of water / m of bed

Pure Resin PMB102-2



- Mixed Bed Resin;
- it is a high capacity mixed bed ion exchange resin consisting of a mixture of a gel, Type I strong base anion resin and a gel strong acid cation resin for direct water purification;
- the conductivity is around 0,1 us/cm;
- suitable for use in regenerable or non-regenerable cartridges, for deionization with high silica removal efficiency and applications for treatment of the R.O. permeate.



Typical Physical & Chemical Characteristics	
Polymer Matrix Structure	Gel polystyrene crosslinked with DVB
Functional Group: Cation Anion	R-SO ₃ ⁻ H ⁺ R ₄ -N-OH ⁻
Ionic Form, as shipped	H ⁺ / OH ⁻
Physical Form and Appearance	Spherical Beads
Sphericity	95% min.
Screen Size Range US Standard Screen	16 ÷ 50 mesh, wet
Particle Size Range	+1,2 mm < 5%, - 0,3 mm < 1%
Volume Ratio (as shipped) Cation Anion	40% PC003H 60% PA102OH
Total Exchange Capacity, Cation (in Na ⁺ form) Cation (in H ⁺ form) Anion (in Cl ⁻ form) Anion (in OH ⁻ form)	2,0 eq/l min. 1,9 eq/l min. 1,3 eq/l min. 1,0 eq/l min.
Water Retention, H ⁺ form OH ⁻ form	45 ÷ 50% 48 ÷ 58%
Shipping Weight (Approx.)	700 ÷ 740 g/l (44 ÷ 46 lbs/cu.ft, approx.)
Max temperature: Non-regenerative bed Regenerative bed	100°C (212°F) 60°C (140°F)
pH Range	0 ÷ 14

REF.	
RA372	



Suggested Operating Conditions	
Minimum Bed Depth	0,6 m (24 inches)
Service Flow Rate	20 ÷ 60 BV/h (2,5 ÷ 7,5 gpm/cu.ft)
Limitations	Extended exposure to strong oxidizers, such as chlorine, hydrogen peroxide and concentrated nitric acid, degrade the structural backbone of the resin and should be avoided

Hydraulic Properties

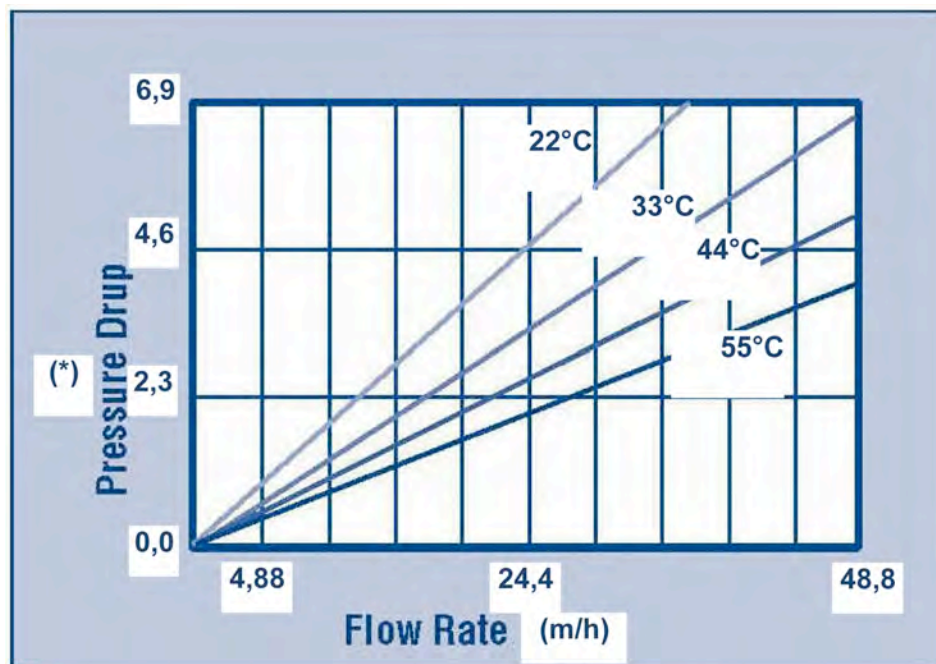

(*) = m of water / m of bed

Pure Resin PMB101-3



- Mixed Bed Resin;
- it is a high capacity mixed bed ion exchange resin consisting of a mixture of a gel, Type I strong base anion resin and a gel strong acid cation resin for direct water purification;
- the conductivity is around 0,06 us/cm;
- suitable for use in regenerable or non-regenerable cartridges, for deionization with high silica removal efficiency and ultrapure water production applications.



Typical Physical & Chemical Characteristics	
Polymer Matrix Structure	Gel polystyrene crosslinked with DVB
Functional Group: Cation Anion	R-SO ₃ ⁻ H ⁺ R ₄ -N-OH ⁻
Ionic Form, as shipped	H ⁺ / OH ⁻
Physical Form and Appearance	Spherical Beads
Sphericity	95% min.
Screen Size Range US Standard Screen	16 ÷ 50 mesh, wet
Particle Size Range	+1,2 mm < 5%, - 0,3 mm < 1%
Volume Ratio (as shipped) Cation Anion	40% PC003H 60% PA101OH
Total Exchange Capacity, Cation (in Na ⁺ form) Cation (in H ⁺ form) Anion (in Cl ⁻ form) Anion (in OH ⁻ form)	2,0 eq/l min. 1,9 eq/l min. 1,3 eq/l min. 1,0 eq/l min.
Water Retention, H ⁺ form OH ⁻ form	45 ÷ 50% 53 ÷ 60%
Shipping Weight (Approx.)	700 ÷ 740 g/l (44 ÷ 46 lbs/cu.ft, approx.)
Max temperature: Non-regenerative bed Regenerative bed	100°C (212°F) 60°C (140°F)
pH Range	0 ÷ 14

REF.	
RA374	



Suggested Operating Conditions	
Minimum Bed Depth	0,6 m (24 inches)
Service Flow Rate	20 ÷ 60 BV/h (2,5 ÷ 7,5 gpm/cu.ft)
Limitations	Extended exposure to strong oxidizers, such as chlorine, hydrogen peroxide and concentrated nitric acid degrade the structural backbone of the resin and should be avoided.

Hydraulic Properties

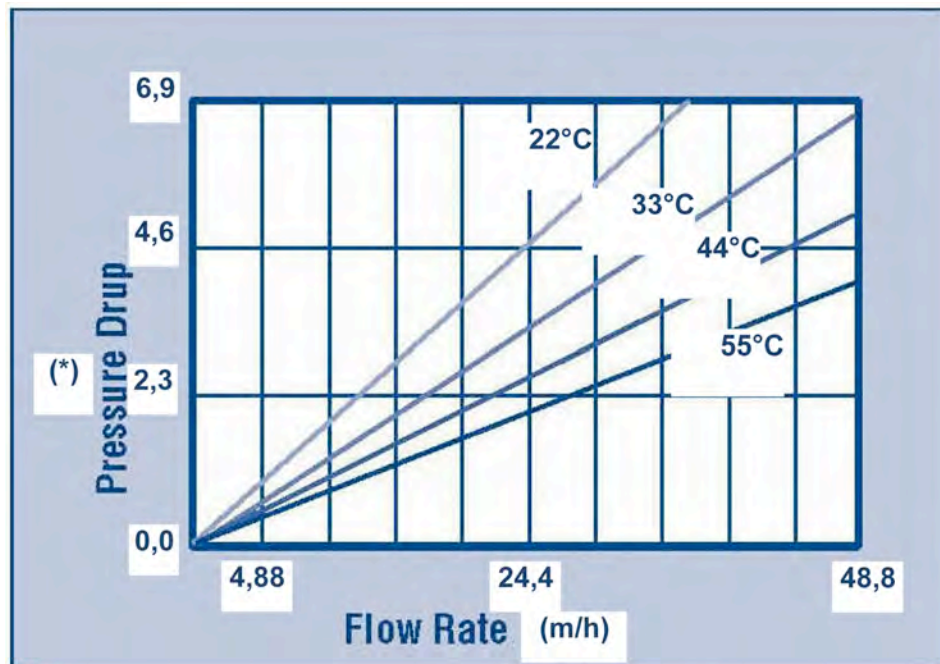

(*) = m of water / m of bed

Pure Resin PMB101 IND-2



- Mixed Bed Resin;
- It is a high capacity indicated mixed bed ion exchange resin consisting of a mixture of a gel, Type I strong base anion resin and a gel strong acid cation resin for direct purification of water;
- The conductivity is 0,1 us/cm max.;
- Suitable for use in regenerable or non-regenerable cartridges, for deionization with high silica removal efficiency and refine water for electrical home applications;
- It changes color from violet to yellow on exhaustion which contains an indicator showing when the resin is exhausted and can no longer treat the water.



Typical Physical & Chemical Characteristics	
Polymer Matrix Structure	Gel polystyrene crosslinked with DVB
Functional Group: Cation Anion	R-SO ₃ ⁻ H ⁺ (color: Violet → Yellow) R ₄ N ⁺ OH ⁻
Ionic Form, as shipped	H ⁺ / OH ⁻
Physical Form and Appearance	Spherical Beads
Sphericity	95% min.
Screen Size Range US Standard Screen	16 ÷ 50 mesh, wet
Particle Size Range	+1,2 mm < 5%, - 0,3 mm < 1%
Volume Ratio (as shipped) Cation Anion	40% PC003H 60% PA101OH
Total Exchange Capacity, Cation (in Na ⁺ form) Anion (in Cl ⁻ form)	2,0 eq/l min. 1,3 eq/l min.
Water Retention, H ⁺ form OH ⁻ form	45 ÷ 50% 53 ÷ 60%
Shipping Weight (Approx.)	700 ÷ 740 g/l (44 ÷ 46 lbs/cu.ft, approx.)
Max temperature: Non-regenerative bed Regenerative bed	100 °C (212 °F) 60 °C (140 °F)
pH Range	0 ÷ 14
REF.	
RA378	



Suggested Operating Conditions

Minimum Bed Depth	0,6 m (24 inches)
Service Flow Rate	20 ÷ 60 BV/h (2,5 ÷ 7,5 gpm/cu.ft)
Limitations	Extended exposure to strong oxidizers, such as chlorine, hydrogen peroxide and concentrated nitric acid, degrade the structural backbone of the resin and should be avoided

Hydraulic Properties

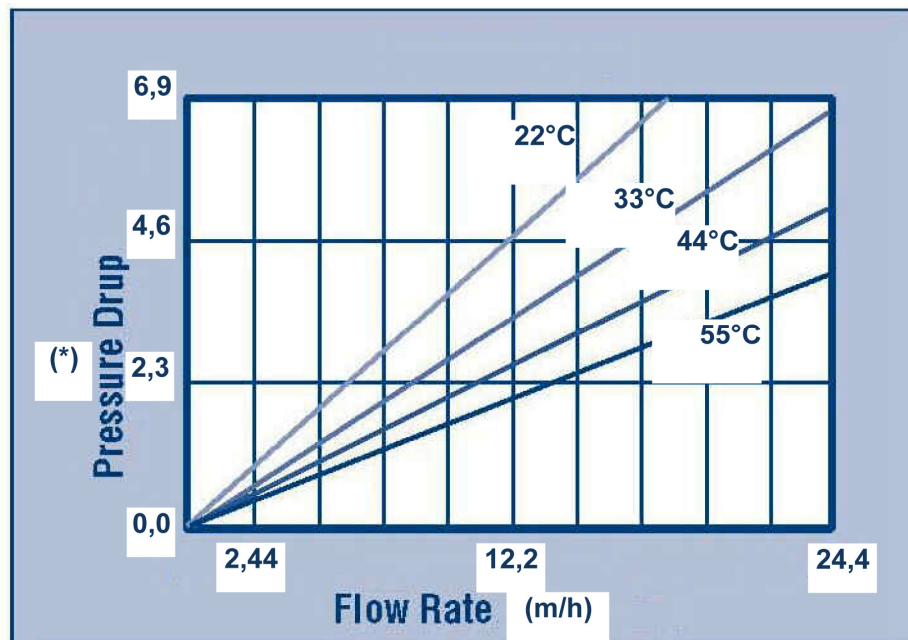

(*) = m of water / m of bed

Pure Resin PMB101 IND-3



- Mixed Bed Resin;
- It is a high capacity indicated mixed bed ion exchange resin consisting of a mixture of a gel, Type I strong base anion resin and a gel strong acid cation resin for direct purification of water;
- The conductivity is 0,1 us/cm max.;
- Suitable for use in regenerable or non-regenerable cartridges, for deionization with high silica removal efficiency and refine water for electrical home applications;
- It changes color from blue to yellow on exhaustion which contains an indicator showing when the resin is exhausted and can no longer treat the water.



Typical Physical & Chemical Characteristics	
Polymer Matrix Structure	Gel polystyrene crosslinked with DVB
Functional Group: Cation Anion	R-SO ₃ ⁻ H ⁺ R ₄ N ⁺ OH ⁻ (color: Blue → Yellow)
Ionic Form, as shipped	H ⁺ / OH ⁻
Physical Form and Appearance	Spherical Beads
Sphericity	95% min.
Screen Size Range US Standard Screen	16 ÷ 50 mesh, wet
Particle Size Range	+1,2 mm < 5%, - 0,3 mm < 1%
Volume Ratio (as shipped) Cation Anion	40% PC003H 60% PA101OH
Total Exchange Capacity, Cation (in Na ⁺ form) Anion (in Cl ⁻ form)	2,0 eq/l min. 1,3 eq/l min.
Water Retention, H ⁺ form OH ⁻ form	45 ÷ 50% 53 ÷ 60%
Shipping Weight (Approx.)	700 ÷ 740 g/l (44 ÷ 46 lbs/cu.ft, approx.)
Max temperature: Non-regenerative bed Regenerative bed	100 °C (212 °F) 60 °C (140 °F)
pH Range	0 ÷ 14
REF.	
RA380	



Suggested Operating Conditions

Minimum Bed Depth	0,6 m (24 inches)
Service Flow Rate	20 ÷ 60 BV/h (2,5 ÷ 7,5 gpm/cu.ft)
Limitations	Extended exposure to strong oxidizers, such as chlorine, hydrogen peroxide and concentrated nitric acid, degrade the structural backbone of the resin and should be avoided

Hydraulic Properties

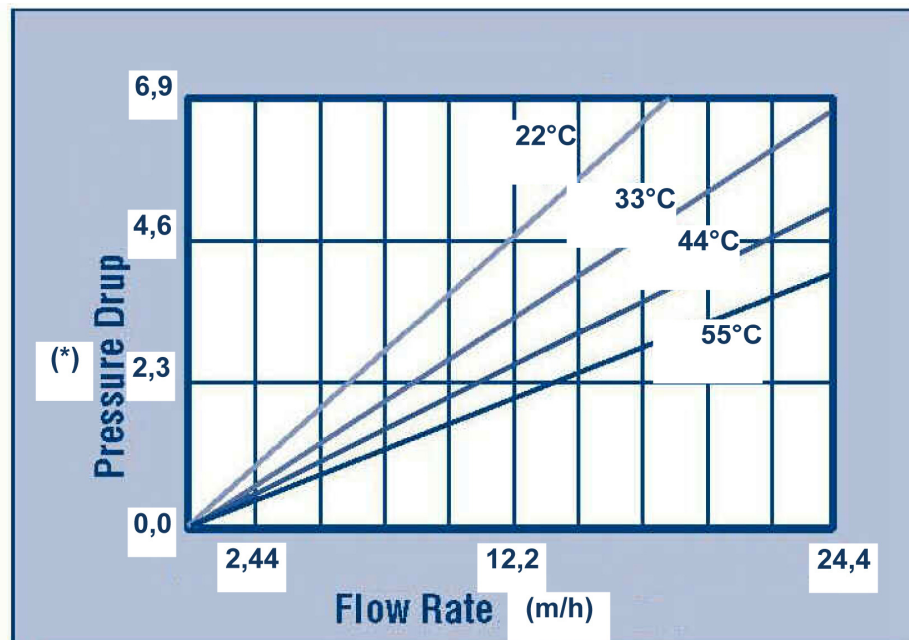

(*) = m of water / m of bed

Pure Resin PS400



- Selective removal of polyvalent ions;
- Macroporous Weak Acid Cation Exchange Resin;
- it is based on the iminodiacetic acid functional group, which has chelating properties for heavy metal ions even against high concentrations of calcium;
- It finds use in processes for extraction and recovery of metals from ores, galvanic plating solutions, picking baths and effluents.



Typical Physical & Chemical Characteristics	
Polymer Matrix Structure	Macroporous, Styrene / DVB
Functional Group	Iminodiacetic
Ionic Form, as shipped	Na ⁺
Physical Form and Appearance	Milky White Spherical Beads
Sphericity	95% min.
Screen Size Range US Standard Screen	16 ÷ 40 mesh, wet
Particle Size Range	0,40 ÷ 1,25 mm ≥ 95
Uniformity Coefficient	1,6 max.
Water Retention, Na ⁺ form	52 ÷ 58%
Reversible Swelling H ⁺ → Na ⁺	40% max.
Shipping Weight	720 ÷ 780 g/l (45 lbs/cu.ft, approx.)
Total Exchange Capacity, Na ⁺ form	≥ 1.95 meq/g (Chelated Cu ²⁺)
pH Range	3 ÷ 12

REF.	
RA376	



Suggested Operating Conditions	
Maximum Temperature, H ⁺ form	100°C (212°F) max.
Operating Flow Rate	15 ÷ 45 (m/hr)
Method of Regeneration	pass 1 eq/l HCl 2~4 BV in 1~1,5 hours, rinse with DI water or soft water until pH = 3~4; pass 1 eq/l NaOH 2~4 BV in 1,5~2 hours, rinse with DI water or soft water until pH = 9



- filter media used for removing soluble iron, manganese, hydrogen sulphide, arsenic and radium from well water supplies;
- the Manganese Greensand Plus has a manganese dioxide coated surface that acts as a catalyst in the oxidation-reduction of iron and manganese;
- the silica sand core allows to better withstand operating conditions in waters that are low in silica, TDS and hardness;
- a pre-filtration with sand and anthracite is recommended;
- the Manganese Greensand Plus can be used in CR (continuous regeneration) or IR (intermittent regeneration) and requires no changes in backwash rate or times or chemical feeds;
- the removal of iron and manganese can be made by using oxidant as chlorine, even in the presence of manganese;
- not shipped in regenerated form; prior to use it is necessary to regenerate with a solution of potassium permanganate contacting the bed for a minimum of 4 hours. A regeneration level of 4 g of potassium permanganate per liter is recommended. Before placing in service the filter must be rinsed of all remaining traces of potassium permanganate;
- dosage Cl_2 (mg/l) = 1 mg/l Fe + 3 mg/l Mn + 6 mg/l H_2S + 8 mg/l NH_3 for service flow rate continuous;
- available in 14,2 liters bags.



Physical properties		Operating conditions	
Colour	black	pH range	6,2 ÷ 8,8
Specific gravity (g/l)	2400	Service flow rate continuous / intermittent ($\text{m}^3/\text{h m}^2$)	12 ÷ 29
Bulk density (g/l)	1410	Backwash flow rate @13°C ($\text{m}^3/\text{h m}^2$)	30
Effective size (mm)	0,30 ÷ 0,35	Backwash bed expansion (%)	35 ÷ 40
Uniform coefficient	1,6	Pressure drop (psi)	10 ÷ 18

Recommended Operating Guidelines	
Intermittently Regeneration (IR)	
Minimum bed depth (mm)	750 single media; 380 each for dual media beds
Backwash Duration	10 minutes (until water is clear)
Regenerant Dosage 6,5% Bleach	65 liters / m^3 diluted in approx. 25 liters of water injected over 30 ÷ 40 minutes
Regenerant Dosage 12% Bleach	25 liters / m^3 diluted in approx. 25 liters of water injected over 30 ÷ 40 minutes

Recommended Operating Guidelines	
Continuous Regeneration (CR)	
Minimum bed depth (mm)	500 Greensand Plus and 380 Anthracite
Backwash Duration	10 minutes (until water is clear)

REF.	
RA074	



- MTM consist of a light weight granular core with a coating of manganese dioxide, and is used for reducing iron, manganese and hydrogen sulphide from water. Its active surface coating oxidizes and precipitate soluble iron and manganese, and hydrogen sulphide is oxidized to a sulphur. The precipitates are filtered out in the granular bed and removed by backwashing;
- compared to other iron removal medias, MTM has many advantages: pH level as low as 6,2 can be treated, dissolved oxygen is not essential, the media light weight reduces backwash water requirements;
- chlorine can be beneficial in extending filter run times;
- MTM requires intermittent or continuous regeneration to maintain its oxidizing capacity, with a weak solution of potassium permanganate;
- regeneration $KMnO_4$ solution from 1,5 to 2 g per liter MTM;
- a new bed should be regenerated at the start up;
- CAUTION: operating the filter after its oxidizing capacity is exhausted will reduce its service life and may cause staining;
- influent limitations: none oil and polyphosphates;
- available in 28,3 liters bags.



PHYSICAL PROPERTIES		OPERATING CONDITIONS	
Colour	dark brown	Bed depth (mm)	600 ÷ 900
Specific gravity (g/l)	2000	Service flow rate (m ³ /h m ²)	8 ÷ 13
Bulk density (g/l)	715	Backwash flow rate (m ³ /h m ²)	20 ÷ 24
Effective size (mm)	0,45	Backwash bed expansion (%)	20 ÷ 40
		Capacity per liter (g)	1,4 Fe or 0,7 Mn
		pH range	6,2 ÷ 8,5
REF.			
RA071			

SERVICE FLOW – PRESSURE DROP

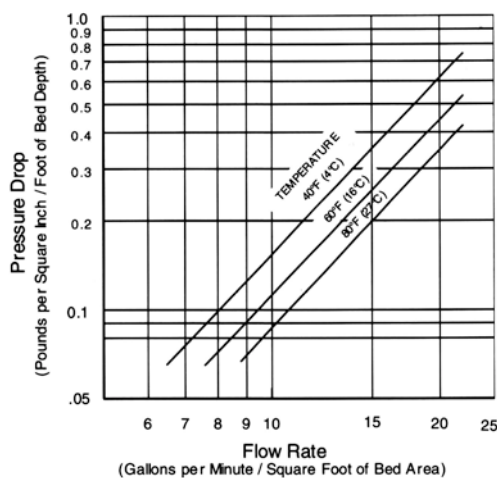

BACKWASH BED EXPANSION

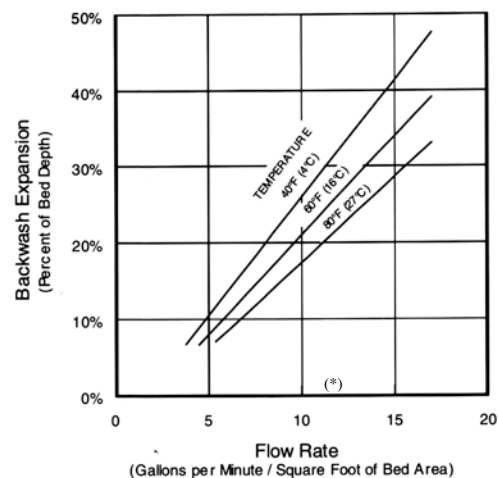

(*) Note: a “Gallon per Minute / Square Foot of Bed Area” is equal to 2,44448 m/h.

BIRM



- Granular filter media used for the reduction of iron and manganese dissolved in the water. In ground water the dissolved iron is usually in the ferrous bicarbonate state and is not filterable; BIRM acts as an insoluble catalyst to enhance the reaction between dissolved oxygen and iron compounds, producing ferric hydroxide which precipitates and may be easily filtered;
- the physical characteristics of BIRM provide an excellent filter media which is easily cleaned by backwashing to remove the precipitant;
- BIRM is not consumed in the iron removal operation;
- available in 28,3 liters bags;
- following are the conditions necessary for a good efficiency of the BIRM:
 - no oil or hydrogen sulphide in the water;
 - pH 6,8 ÷ 9,0 (if water contains also manganese pH has to be 8,0 ÷ 8,5);
 - dissolved oxygen content must be equal to at least 15% of the iron content;
 - alkalinity should be greater than two times the combined sulphate and chloride concentration;



CAUTION: chlorination greatly reduces BIRM activity.

PHYSICAL PROPERTIES		OPERATING CONDITIONS	
Colour	black	Bed depth (mm)	750 ÷ 900
Specific gravity (g/l)	2000	Service flow rate (m ³ /h m ²)	9 ÷ 13
Bulk density (g/l)	560 ÷ 640	Backwash flow rate (m ³ /h m ²)	24 ÷ 30
Effective size (mm)	0,6	Backwash bed expansion (%)	20 ÷ 40

REF.	
RA072	

SERVICE FLOW – PRESSURE DROP

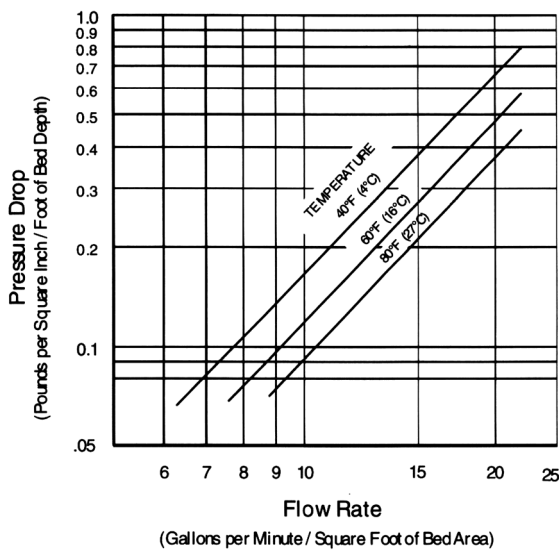

BACKWASH BED EXPANSION

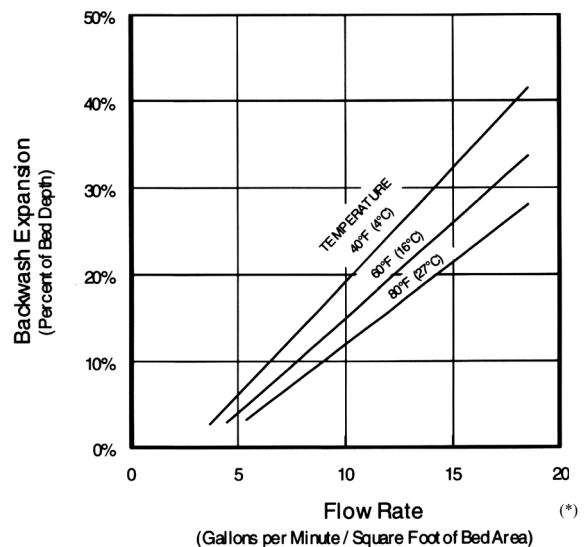

(*) Note: a "Gallon per Minute / Square Foot of Bed Area" is equal to 2,44448 m/h.

PYROLUSITE



- PYROLUSITE is manganese dioxide (MnO_2) of very good quality and pureness obtained by washing, drying and screening of mineral selected for the specific catalytic activity;
- used as catalyser for the reduction of iron and manganese dissolved in the water, by sand filters, mixed 20÷50 % with sand 0,4÷0,8 / 0,7÷1,2 mm;
- does not require a compulsory regeneration with $KMnO_4$, but you can do a continuous chlorination or a chlorination during the backwash;
- PYROLUSITE complies the standard UNI ISO EN 13752 “Products for potable water treatment”;
- hardness 3° ÷ 5° Mosh;
- available in 25 kg bags.



Physical Properties	
Colour	brown
Bulk density (g/l)	2000
Effective size (mm)	0,3 ÷ 0,8
Mn (%)	80

Operating Conditions	
Composition	Mixed 20÷50 % with sand 0,4÷0,8 / 0,7÷1,2 mm
Suggested filtration speed (m/h)	≤ 10
Max backwash speed ($m^3/h m^2$)	25
Min contact time (min)	6

REF.	
RA069	

Activated Carbon



- REF. RA204 (it is not suitable for treatment of water intended for human consumption), RA206, RA208, RA212, RA212A, RA214 and RA214A;
- RA206, RA208, RA212, RA212A, RA214 and RA214A are in conformity with the rule UNI ISO EN 12915-1 : 2004 "Chemicals used for treatment of water intended for human consumption";
- range of granular activated carbons designed for reduction of chlorine and organic contaminants dissolved in water;
- manufactured from select grades of bituminous (or vegetal origin) coal, with a thermal activation process at strictly controlled temperature to obtain a large surface area and a porous structure allowing the adsorption of low and high molecular weight organic compounds;
- high density activated carbons with good resistance to the attrition and mechanical stocks;
- activated carbon require periodic backwashing to eliminate accumulated suspended matters and to regrade the filter bed;
- a good backwashing of the AC filter bed of the start-up is required.



REF.	TYPE	ORIGIN	SIZE (mm)	BULK DENSITY (g/l)	BET (m ² /g)	IODINE NUMBER (mg/g)	WEIGHT (kg)	VOLUME (liters)	PACKAGING
RA204	SC45 cylindrical	Mineral	4	530	700	750	25	47	bag
RA206	GAC 8x30	Vegetal	0,6 ÷ 2,4	550	1100	1000	25	46	bag
RA208	GAC 12x40	Vegetal	0,4 ÷ 1,7	550	1100	1000	25	46	bag
RA212 (*)	Norit GAC 8x30	Vegetal	0,6 ÷ 2,4	500	1100	950	25	50	bag
RA212A (*)	Norit GAC 8x30	Vegetal	0,6 ÷ 2,4	500	1100	950	500	1000	Big bag
RA214 (*)	Norit GAC 12x40	Vegetal	0,4 ÷ 1,7	500	1100	950	25	50	bag
RA214A (*)	Norit GAC 12x40	Vegetal	0,4 ÷ 1,7	500	1100	950	500	1000	Big bag

Operating conditions

Bed depth (mm) (dechlorination)	650 ÷ 750
Service flow rate (m ³ /h m ²) (dechlorination)	12 ÷ 15
Backwash flow rate (m ³ /h m ²)	24 ÷ 30
Backwash bed expansion (%)	30 ÷ 40

(*) not available in stock.

Filter Sand and Gravel



- REF. RA049, RA050, RA051, RA052 and RA053;
- filter sand and gravel shape of alluvium origin, uncrushed;
- high contents of silica, selected for specific use in water filtration for potable and industrial application;
- hardness 7° Mosh.



REF.	SIZE (mm)	BAG WEIGHT (kg)	
RA049	0,4 ÷ 0,8	25	
RA050	0,8 ÷ 1,2	25	
RA051	1,0 ÷ 2,0	25	
RA053	2,0 ÷ 3,0	25	
RA052	3,0 ÷ 5,0	25	

Physical properties	
Colour	white
Specific gravity (g/l)	2650
Bulk density (g/l)	1500
SiO ₂ content	> 96 %
Humidity	0,3 % max
Melting point	1700 g/c
pH	8

Operating conditions	
Bed depth (mm) (sand filter)	450 ÷ 750
Service flow rate (m ³ /h m ²)	8 ÷ 12
Backwash flow rate (m ³ /h m ²)	30 ÷ 42
Backwash bed expansion (%)	5 ÷ 10



- granular anthracite selected per gradation, hardness and purity for specific use in potable and industrial water filtration;
- the high filtering efficiency of anthracite is due to its angular shape, that allows high filtering speed, longer filter runs and less head loss;
- excellent media with density lower than sand, the anthracite is usually used in multimedia filters;
- the ANTHRACITE complies the standard UNI ISO EN 12909 "Products used for treatment of water intended for human consumption";
- minimum carbon contents 90%, low silica, hardness 3° Mosh average.



REF.	SIZE (mm)	WEIGHT (kg)	PACKAGE	
RA060	0,6 ÷ 1,0	25	Bag	
RA061	2,0 ÷ 3,0	25	Bag	
RA061A	2,0 ÷ 3,0	1000	Big bag	

Physical properties	
Bulk density (g/l)	950
Absolute density (g/ml)	1400
Humidity packaging	2 % max
Ashes	4 % (±2)
Substances volatiles	3 % (±1)
Sulphur	0,5 % max
pH	8 ÷ 10

Operating conditions:

- monolayer bed depth 600 ÷ 900 mm;
- top bed depth in multilayer beds 250 ÷ 450 mm;
- service flow rate following specific conditions;
- backwash flow rate 28 ÷ 35 m³/h m²;
- bed expansion 20 ÷ 30%.

Calcite



- CALCITE is a natural crushed and screened calcium carbonate media which is used to neutralize low pH waters;
- acidic water slowly dissolves the calcium carbonate to raise the pH which reduces the potential leaching of copper, lead and other metals found in typical plumbing systems;
- one of the advantages of CALCITE is its self-limiting property, that corrects pH only enough to reach a non corrosive equilibrium;
- of course CALCITE will increase the hardness of the water;
- periodic backwashing of the bed is necessary to keep in working order the system;
- the CALCITE bed will have to be periodically replenished as the CALCITE is depleted;
- gravel support bed is recommended;
- available in 15,6 liters bags.



Physical properties		Operating conditions	
Colour	white	Bed depth (mm)	600 ÷ 750
Specific gravity (g/l)	2700	Service flow rate (m ³ /h m ²)	7 ÷ 15
Bulk density (g/l)	1450	Backwash flow rate (m ³ /h m ²)	20 ÷ 30
Effective size (mm)	0,4 ÷ 1,1	Backwash bed expansion (%)	≥ 50
Composition	CaCO ₃ 95% min. MgCO ₃ 3% max.	pH range	5,0 ÷ 7,0

REF.	
RA073	

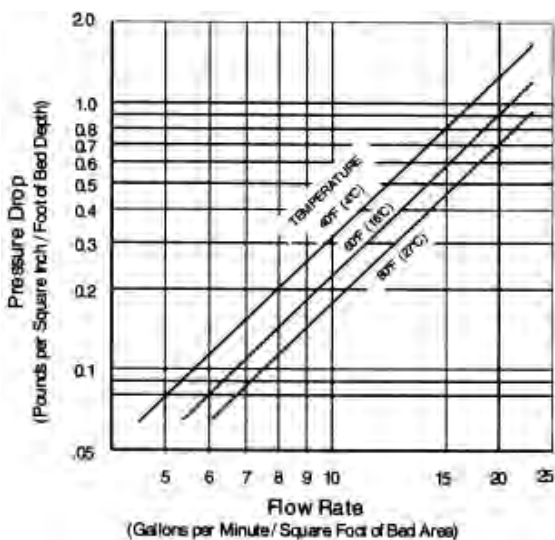

Service flow – pressure drop

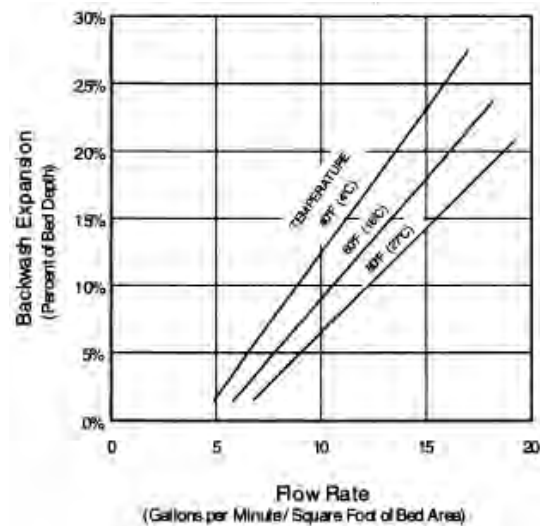

Backwash bed expansion

(*) Note: a "Gallon per Minute / Square Foot of Bed Area" is equal to 2,44448 m/h .

Filter AG



- Filter-Ag is a non-hydrous silicon dioxide media which can be used as highly efficient filter media for the reduction of suspended matter. Its fractured edges and irregular surface provides an high surface area and complex flow path for efficient filtration;
- less pressure loss through a bed of Filter-Ag than through most other filter medias;
- light weight requires lower backwash rates than other filter medias;
- upon installation allow bed to soak overnight before backwashing;
- available in 28,3 liters bags.



Physical properties		Operating conditions	
Colour	light grey	Bed depth (mm)	600 ÷ 900
Specific gravity (g/l)	2250	Service flow rate (m ³ /h m ²)	12 ÷ 13
Bulk density (g/l)	380 ÷ 420	Backwash flow rate (m ³ /h m ²)	20 ÷ 24
Effective size (mm)	0,5 ÷ 2,0	Backwash bed expansion (%) of bed depth	20 ÷ 40
		Freeboard of bed depth (%)	≥ 50

REF.	
RA059	

Service flow – pressure drop

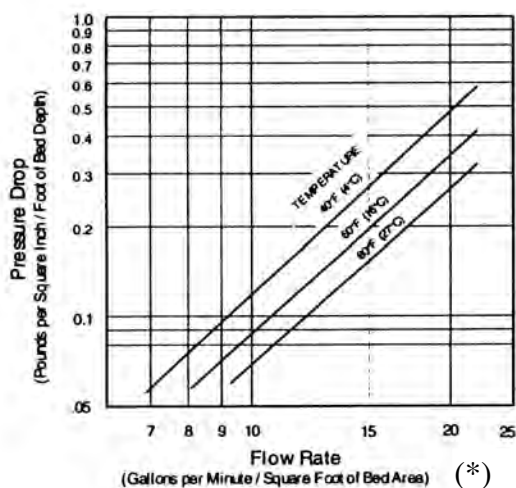

Backwash bed expansion

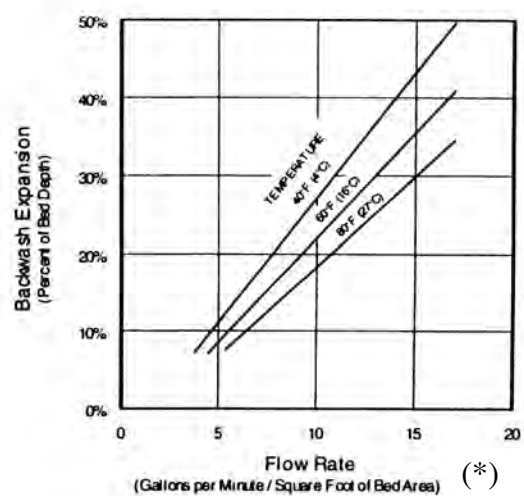

(*) Note: a “Gallon per Minute / Square Foot of Bed Area” is equal to 2,44448 m/h .

Filter AG Plus



- Filter-Ag Plus is a clinoptilolite natural media with a large surface area and microporous structure which can be used as highly efficient filter media for the reduction of suspended matter. Its irregular surface and 3 micron void spaces provides a surface area over 100 times greater than silica sand;
- its low pressure drop, high service flow rates and high bed loadings combined with lower backwash frequency allow economy in equipment downsizing and reduced pumping requirements;
- utilizing deep bed filtration can typically reduce suspended solids down to 5 micron or less range;
- Filter Ag Plus can be applied to systems designed for either pressure or gravity flow;
- available in 28,3 liters bags.



Physical properties		Operating conditions	
Colour	White to off white	Bed depth (mm)	600 ÷ 1200 (900 for optimal filtration)
Specific gravity (g/l)	2200	Service flow rate (m ³ /h m ²)	30 ÷ 50
Bulk density (g/l)	800	Backwash flow rate (m ³ /h m ²)	35 ÷ 45
Effective size (mm)	0,55	Backwash bed expansion (%) of bed depth	30 ÷ 40
		Freeboard of bed depth (%)	≥ 50

REF.	
RA058	

Service flow – pressure drop

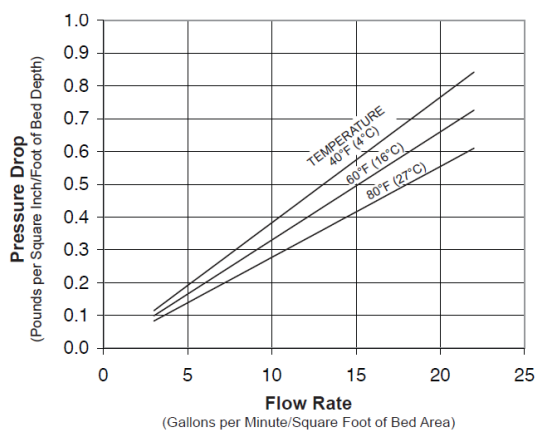

Backwash bed expansion

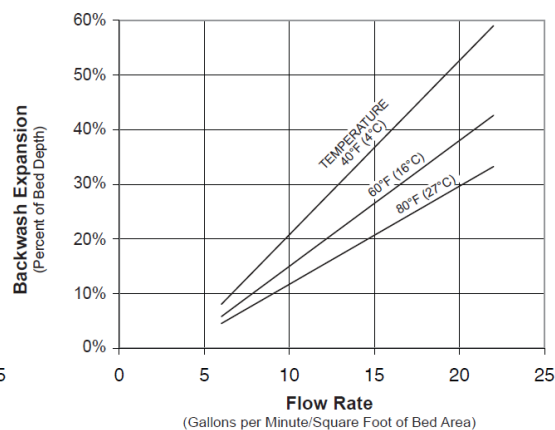

(*) Note: a “Gallon per Minute / Square Foot of Bed Area” is equal to 2,44448 m/h .

GFH (Granular Ferric Hydroxide)



- the granular ferric hydroxide GFH is an adsorbent for selective removal of arsenic (both arsenite and arsenate), phosphate, selenium, antimony, molybdenum and other heavy metals from natural water;
- preoxidation is not required for arsenic removal applications;
- once the media has exhausted its adsorption capacity, it is removed from the vessel and replaced with new media;
- the simplicity of this process is very attractive for small installations and wellhead applications;
- active substance $\text{Fe}(\text{OH})_3 + \beta\text{-FeOOH}$;
- dry solids content 57% ($\pm 10\%$).



REF.	WEIGHT (kg)	PACKAGING	
RA068	30	Drum	
RA068B	800	Big bag	

Physical properties (with water content 45%):	
Density of grains (g/l)	1590
Bulk density (g/l) backwashed	1150 ($\pm 10\%$)
Particle size range (mm)	0,3 ÷ 2
Specific surface (m^2/g)	> 200
Porosity of grains (%)	72 ÷ 77
Bulk porosity (%)	22 ÷ 28

Operating conditions	
Bed depth (m)	0,6 ÷ 1,6
Specific flow rate ($\text{m}^3/\text{h m}^2$)	5 ÷ 20
Contact time (minutes)	3 ÷ 6
Backwash flow rate ($\text{m}^3/\text{h m}^2$)	25 ÷ 30
Expansion free volume (%) of bed depth	30 ÷ 50
Pressure loss max (bar)	0,5
Operation temperature max ($^{\circ}\text{C}$)	60
AsO_4^{3-} Arsenic adsorption density in the drinking water processing (g/kg)	1 ÷ 5 (**)

(**) the adsorption density depends on pH and water chemistry.



- ECOMIX is a granular filtering media, suitable for remove natural organic matter, hardness, iron, manganese and ammonia in a wide pH range and without any oxidant products dosage;
- ECOMIX is a homogeneous mixture of five high quality ion-exchange and adsorption materials of natural and synthetic origin;
- you can use ECOMIX as a ion-exchange resin and regenerate it with sodium chloride (NaCl);
- wide range of raw water as indicated in the “Limit Concentration Table” below;
- ECOMIX can treat water with high concentration of Fe and Mn, and with max TDS = 4000 mg/l;
- to calculate filter capacity, one should only consider water hardness and ion-exchange capacity (don't consider Fe and Mn data);
- NSF/ANSI 44, 61 & 372 certified;
- shipping weight 0,75 kg / liter;
- available in 12,0 liters bags.



REF.	TYPE	ION EXCHANGE CAPACITY (eq/l)	ION EXCHANGE CAPACITY (g CaCO ₃ /l)	DOSE OF REGENERANT (g NaCl 100% per liter)	
RA080	Ecomix - A	0,75	35	100	
RA081	Ecomix - C	0,65	30	100	

- ECOMIX A is preferred when the contaminants to be removed are mainly hardness and iron;
- ECOMIX C is preferred when the contaminants to be removed are mainly organic matter.

WARNING: if you use only a part of the product contained in a bag, you have make sure that all the contents are mixed, in order to homogenize the product before spilling. ECOMIX is a mixture of five materials with different specific weight and different particle size, which if not well mixed tends to stratify.



Limit Concentration Tables

RA080	Hardness (ppm CaC O₃)	Fe (mg/l) (ppm)	Mn (mg/l) (ppm)	COD (ppm O₂)	Ammonia (mg/l) (ppm)	TDS (ppm)
Raw water concentration limits	< 750	< 15	< 3	< 20	< 4	< 4000
Quality of purified water	≤ 20	< 0,3	< 0,1	< 10	< 0,5	No changes

RA081	Hardness (ppm CaC O₃)	Fe (mg/l) (ppm)	Mn (mg/l) (ppm)	COD (ppm O₂)	Ammonia (mg/l) (ppm)	TDS (ppm)
Raw water concentration limits	< 750	< 10	< 3	< 20	< 4	< 4000
Quality of purified water	≤ 20	< 0,3	< 0,1	< 4	< 0,5	No changes

OPERATING CONDITIONS		UNIT OF MEASUREMENT
Maximum operating temperature	40	°C
pH range	5 ÷ 9	
Minimum bed depth	500	mm
Optimum bed depth	800	mm
Service flow rate	20 ÷ 25	m ³ /h m ²
Backwash flow rate (15÷20 min)	10 ÷ 15	m ³ /h m ²
Regeneration flow rate (45÷65 min)	3 ÷ 5	m ³ /h m ²
Active chlorine	< 1	mg/l (ppm)
Free bed volume	≥ 40	%

COMMONLY USED PRESSURE VESSELS:

(*) for Ecomix A

	8x35	8x44	10x35	10x54	12x52	13x54	14x65	16x65	21x60
Volume of Ecomix (liters)	16	20	24	36	48	60	72	96	144
Flow Capacity (m ³ /h)	0,8	0,8	1,2	1,2	1,6	2,0	2,5	3,0	5,5
IX Capacity (kg CaCO ₃) (*)	0,56	0,7	0,8	1,3	1,7	2,1	2,5	3,3	5,0
Salt Requirement (kg)	1,6	2,0	2,4	3,6	4,8	6,0	7,2	9,6	14,4
Backwash Flow Rate (m ³ /h)	0,4	0,4	0,6	0,6	0,9	1,1	1,2	1,6	2,7



- Corosex is designed for use in filters to neutralize acidity by increasing the pH value;
- By neutralizing the free carbon dioxide in water, Corosex can correct acidic water conditions and render it less corrosive. Corosex, being a highly reactive magnesium oxide, is used most effectively where pH correction is substantial or high flow conditions are in use. pH correction and media consumption are affected by a number of water chemical variables. Being soluble to acidity, Corosex will slowly dissolve and will need to be replenished periodically;
- On a per weight basis, magnesium oxide can neutralize five times more acidity than can calcium carbonate. This results in greatly reduced chemical usage for the same pH correction. Please note; under certain low flow conditions, Corosex may overcorrect and create a highly basic (high pH) condition;
- Under certain hardness conditions, pH correction can cause hardness minerals to precipitate out of solution, resulting in cementing or solidification of the Corosex mineral bed. Upflow service is generally recommended with hardness exceeding 9 °F. Always use an in-line filter ahead of an upflow system to prevent plugging of the lower distribution screen;
- As Corosex's magnesium oxide neutralizes the water, it will increase hardness and a softener may become necessary after the neutralizing filter;
- Corosex can be effectively combined with Calcite to combine the high flow neutralization properties of Corosex, along with the slower reacting low flow properties of Calcite, reducing potentially high basic properties due to overcorrection;
- High degree of activity and speed of correction allowing high flow;
- High capacity...less chemical usage;
- NSF/ANSI 60 certified;
- Available in 18,7 liters bags.

REF.	
RA075	



Physical properties	
Colour	Brownish white
Specific gravity (g/l)	3600
Bulk density (g/l)	1200
Effective size (mm)	1,4
Uniformity coefficient	1,7
Composition	MgO 97% min.
Mesh size	6 x 16

Operating conditions	
Bed depth (mm)	600 ÷ 750
Service flow rate (m ³ /h m ²)	12 ÷ 15
Backwash flow rate (m ³ /h m ²)	25 ÷ 30
Backwash bed expansion (%)	≥ 50
pH range	4,5 ÷ 6,0

- Downflow service is generally satisfactory on waters with a hardness of less than 9 °F or where it's combined with Calcite at least 50-50. Upflow service is generally recommended with hardness exceeding 9 °F to prevent cementing of the Corosex bed;
- Use distributors designed for upflow applications;
- A gravel support bed is recommended;
- Backwash frequently to prevent possible cementing;
- Max usage 100 mg/l.

Service Flow Pressure Drop

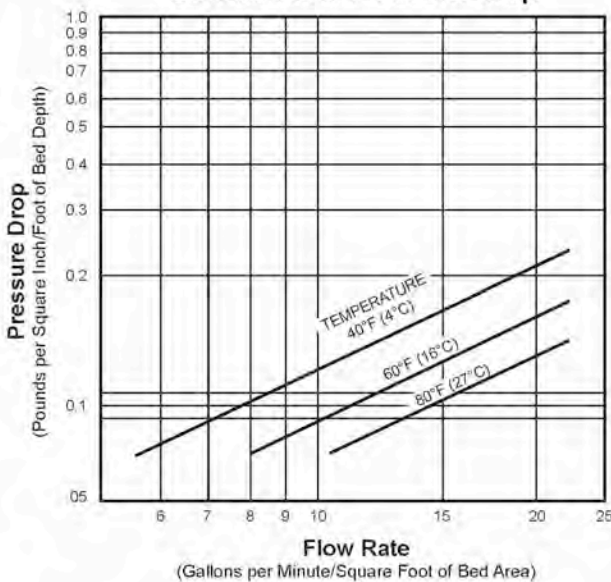

Backwash Bed Expansion

Due to Corosex's high density and large particle size, a new bed is difficult to expand, but it is still imperative to backwash in order to keep the bed clean. Over time, as the media is consumed, the particle size will decrease and backwash bed expansion will begin to occur.

(*) Note: a "Gallon per Minute / Square Foot of Bed Area" is equal to 2,44448 m/h .



Residential R.O. components



1,8" Residential CSM Membranes



RESIDENTIAL

RO elements for residential use (1.8 inch diameter)

CSM[®]

SPECIFICATIONS:

General Features

Model Name	Permeate Flow Rate GPD (L/day)	Salt Rejection %
RE1810-30	30 (114)	98.0%
RE1810-50	50 (189)	98.0%
RE1812-35	35 (132)	98.0%
RE1812-50	50 (189)	98.0%
RE1812-60	60 (227)	98.0%
RE1812-80	80 (303)	98.0%

- The stated product performance is based on data taken after 30 minutes of operation at the following test conditions:
 - 200 mg/L NaCl solution at 60 psig (0.41 MPa) applied pressure
 - 15% recovery
 - 77 °F (25 °C)
 - pH 6.5–7.0
- Dry type elements are vacuum leak tested using the San Diego Protocol.
- Permeate flow rate for each element may vary but will be no more than 15%.
- Dry elements are packaged in a polyethylene bag
 - α Wet elements are packaged in a polyethylene bag containing SB(4g/L) + HCl(0.51g/L) solution.

Membrane type: Thin-Film Composite
Membrane material: Polyamide (PA)
Element configuration: Spiral-Wound, Tape Wrapping

Dimensions

Model Name	A	B	C	D	E
RE1810-30	0.67 (17mm)	0.55 (14mm)	10.08 (256mm)	0.98 (25mm)	1.77 (45mm)
RE1810-50					
RE1812-35	0.67 (17mm)	0.87 (22mm)	11.73 (298mm)	0.98 (25mm)	1.77 (45mm)
RE1812-50					
RE1812-60					
RE1812-80					

*All measurement are in inches



1,8" Residential CSM Membranes



These model names are tested and certified under NSF/ANSI standard 58, material requirement only (excluding RE1810-30)

RESIDENTIAL

RO elements for residential use (1.8 inch diameter)

CSM[®]

APPLICATION DATA:

Operating Limits

· Max. Operating Pressure	125 psi (0.86 MPa)
· Max. Feed Flow Rate	2 gpm (0.45 m ³ /hr)
· Max. Operating Temperature	113 °F (45 °C)
· Operating pH Range	2.0–11.0
· Max. Turbidity	1.0 NTU
· Max. SDI (15 min)	5.0
· Max. Chlorine Concentration	< 0.1 mg/L

The information provided in this document is solely for informative purposes. It is the user's responsibility to ensure the appropriate usage of this product. Woongjin Chemical assumes no obligation, liability or damages incurred for the misuse of the product or for the information provided in this document. This document does not express or implies any warranty as to the merchantability or fitness of the products.

GENERAL HANDLING PROCEDURES

- Elements contained in the boxes must be kept dry at room temperature (7–32°C; 40–95°F) and should not be stored in direct sunlight. If the polyethylene bag is damaged, a new preservative solution (sodium bisulfite) must be added and air-tight sealed to prevent drying and biological growth.
- Permeate from the first hour of operation should be discarded to flush out the preservative solution.
- Elements should be immersed in a preservative solution during storage, shipping and system shutdowns to prevent biological growth and freezing. The standard storage solution contains 1% by weight sodium bisulfite or sodium metabisulfite (food grade). For short term storage (i.e. one week or less) 1% by weight sodium metabisulfite solution is adequate for preventing biological growth.
- Keep elements moist at all times after initial wetting.
- Only use chemicals compatible with the membrane elements and components. Use of such chemicals may void the element limited warranty.
- Permeate pressure must always be equal or less than the feed/concentrate pressure. Damage caused by permeate back pressure voids the element limited warranty.

REF.	OLD REF.	MODEL NAME	
		RE1810-30	
		RE1812-35	
MCRE1812-50	DA050	RE1812-50	
MCRE1812-60	DA051	RE1812-60	
MCRE1812-80	DA052	RE1812-80	

2" - 2,8" Residential CSM Membranes



RESIDENTIAL

RO elements for residential use (2.0 and 2.8 inch diameters)

CSM[®]

SPECIFICATIONS:

General Features

Model Name	Permeate Flow Rate GPD (L/day)	Salt Rejection (%)
RE2012-100	100 (397)	98.0
RE2812-300	300 (1,136)	96.0

- The stated product performance is based on data taken after 30 minutes of operation at the following test conditions:
 - 200 mg/L NaCl solution at 60 psig (0.41 MPa) applied pressure
 - 15% recovery
 - 77 °F (25 °C)
 - pH 6.5–7.0
- Minimum salt rejection is 96.0%.
- Permeate flow rate for each element may vary but will be no more than 15%.
- Wet elements are packaged in a polyethylene bag containing 1.0% SBS (sodium bisulfite) solution.

Membrane type: Thin-Film Composite
Membrane material: Polyamide (PA)
Element configuration: Spiral-Wound, Tape Wrapping

Dimensions

Model Name	A	B	C	D	E
RE2012-100	0.67 (17)	0.5 (12)	11.7 (298)	0.9 (23)	1.9 (48)
RE2812-300	0.67 (17)	0.9 (22)	11.7 (298)	0.9 (22)	2.9 (74)

*All measurements are in inches (millimeters)



2" - 2,8" Residential CSM Membranes



RESIDENTIAL

RO elements for residential use (2.0 and 2.8 inch diameters)

CSM[®]

APPLICATION DATA:

Operating Limits

· Max. Operating Pressure	125 psi (0.86 MPa)
· Max. Feed Flow Rate	2 gpm (0.45 m ³ /hr)
· Max. Operating Temperature	113 °F (45 °C)
· Operating pH Range	2.0–11.0
· Max. Turbidity	1.0 NTU
· Max. SDI (15 min)	5.0
· Max. Chlorine Concentration	< 0.1 mg/L

The information provided in this document is solely for informative purposes. It is the user's responsibility to ensure the appropriate usage of this product. Toray Chemical Korea Inc. assumes no obligation, liability or damages incurred for the misuse of the product or for the information provided in this document. This document does not express or implies any warranty as to the merchantability or fitness of the product.

GENERAL HANDLING PROCEDURES

- Elements contained in the boxes must be kept dry at room temperature (7–32°C; 40–95°F) and should not be stored in direct sunlight. If the polyethylene bag is damaged, a new preservative solution (sodium bisulfite) must be added and air-tight sealed to prevent drying and biological growth.
- When running the system for the first time, the permeate should be discarded continuously at least 1 hour.
- Keep elements moistly at all times after initial wetting.
- Elements should be immersed in a preservative solution during storage, shipping and system shutdowns to prevent biological growth and freezing. The standard storage solution contains 1% by weight sodium bisulfite or sodium metabisulfite (food grade). For short term storage (i.e. one week or less) 1% by weight sodium metabisulfite solution is adequate for preventing from biological growth.
- Only use chemicals compatible with the membrane elements and components. Use of such chemicals may void the element limited warranty.
- Permeate pressure must always be equal or less than the feed/concentrate pressure. Damage caused by permeate back pressure voids the element limited warranty.

REF.	OLD REF.	MODEL NAME	
MCRE2012-100	DA053	RE2012-100	
MCRE2812-300	DB030	RE2812-300	

2" Residential CSM Membranes



SPECIFICATIONS:

General Features

Model Name	Active Membrane Area ft ² (m ²)	Permeate Flow Rate GPD (L/day)	Salt Rejection (%)
RE2012-150	6.4 (0.59)	150 (567.8)	98.0

1. The stated product performance is based on data taken after 30 minutes of operation at the following test conditions:

- **200 mg/L NaCl solution at 60 psig (0.41 MPa) applied pressure**
- **15% recovery**
- **77 °F (25 °C)**
- **pH 6.5–7.0**

2. Minimum salt rejection is 96.0%.

3. Dry type elements are vacuum leak tested using the CSM integrity test.

4. Permeate flow rate for each element may vary but will be no more than 15%.

5. Dry elements are packaged in a polyethylene bag.

Membrane type:	Thin-Film Composite
Membrane material:	Polyamide (PA)
Element configuration:	Spiral-Wound, Tape Wrapping

Dimensions

Model Name	A	B	C	D	E
RE2012-150	0.67 (17)	0.5 (12)	11.7 (298)	0.9 (23)	1.9 (48)

*All measurements are in inches (millimeters).

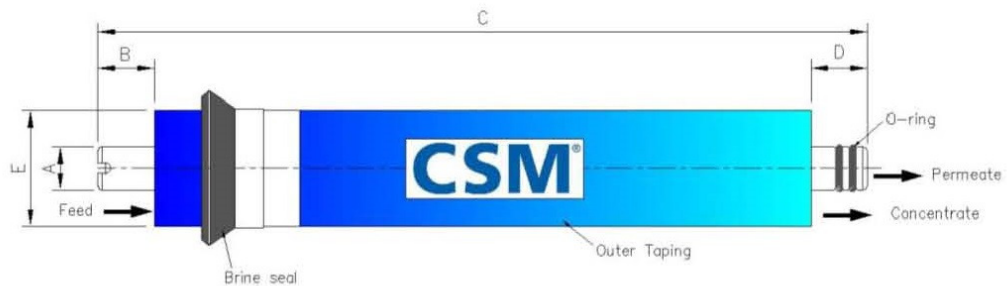



RESIDENTIAL

High flux RO elements for residential use

CSM®

APPLICATION DATA:

Operating Limits

· Max. Operating Pressure	150 psi (1.03 MPa)
· Max. Feed Flow Rate	2 gpm (0.45 m ³ /hr)
· Max. Operating Temperature	113 °F (45 °C)
· Operating pH Range	2.0–11.0
· Max. Turbidity	1.0 NTU
· Max. SDI (15 min)	5.0
· Max. Chlorine Concentration	< 0.1 mg/L

The information provided in this document is solely for informative purposes. It is the user's responsibility to ensure the appropriate usage of this product. Toray Chemical Korea Inc. assumes no obligation, liability or damages incurred for the misuse of the product or for the information provided in this document. This document does not express or imply any warranty as to the merchantability or fitness of the product.

GENERAL HANDLING PROCEDURES

- Elements contained in the boxes must be kept dry at room temperature (7–32°C; 40–95°F) and should not be stored in direct sunlight.
- When running the system for the first time, the permeate should be discarded continuously at least 1 hour.
- Keep elements moistly at all times after initial wetting.
- Elements should be immersed in a preservative solution during storage, shipping and system shutdowns to prevent biological growth and freezing. The standard storage solution contains 1% by weight sodium bisulfite or sodium metabisulfite (food grade). For short term storage (i.e. one week or less) 1% by weight sodium metabisulfite solution is adequate for preventing from biological growth.
- Only use chemicals compatible with the membrane elements and components. Use of such chemicals may void the element limited warranty. For additional information on use of approved chemicals please contact your nearest CSM representative.
- Permeate pressure must always be equal or less than the feed/concentrate pressure. Damage caused by permeate back pressure voids the element limited warranty.

REF.	OLD REF.	MODEL NAME	
MCRE2012-150	-	RE2012-150	

2" Residential CSM Membranes



RESIDENTIAL

Low pressure grade RO elements for residential use

CSM®

SPECIFICATIONS:

General Features

Model Name	Permeate Flow Rate GPD (L/day)	Salt Rejection %
RE2010-LP	30 (114)	93.0%
RE2012-LP	50 (189)	93.0%
RE2012-LPF	60 (227)	93.0%

1. The stated product performance is based on data taken after 30 minutes of operation at the following test conditions:

- 100 mg/L NaCl solution at 20 psig (0.14 MPa) applied pressure
- 15% recovery
- 77 °F (25 °C)
- pH 6.5–7.0

2. Dry type elements are vacuum leak tested using the San Diego Protocol.

3. Permeate flow rate for each element may vary but will be no more than 15%.

4. Dry elements are packaged in a polyethylene bag

▣ Wet elements are packaged in a polyethylene bag containing SB(4g/L) + HCl(0.51g/L) solution.

Membrane type: Thin-Film Composite

Membrane material: Polyamide (PA)

Element configuration: Spiral-Wound, Tape Wrapping

Dimensions

Model Name	A	B	C	D	E
RE2010-LP	0.67	0.55	10.08	0.98	1.91
RE2012-LP	0.67	0.47	11.73	0.91	1.91
RE2012-LPF	0.67	0.47	11.73	0.91	1.91

*All measurement are in inches

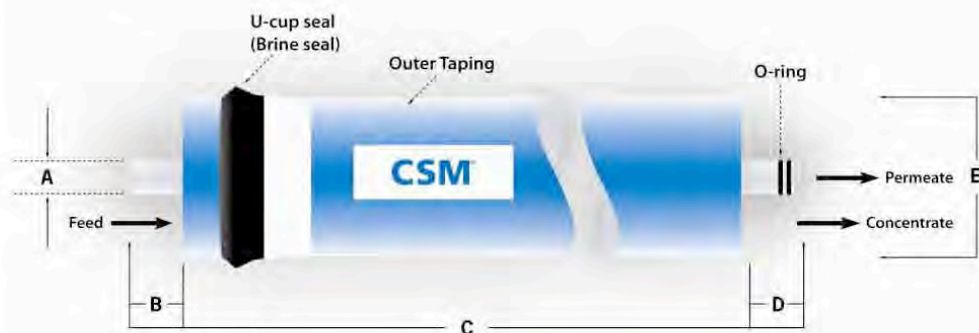

2" Residential CSM Membranes



RESIDENTIAL

Low pressure grade RO elements for residential use

CSM[®]

APPLICATION DATA:

Operating Limits

· Max. Operating Pressure	125 psi (0.86 MPa)
· Max. Feed Flow Rate	2 gpm (0.45 m ³ /hr)
· Max. Operating Temperature	113 °F (45 °C)
· Operating pH Range	2.0–11.0
· Max. Turbidity	1.0 NTU
· Max. SDI (15 min)	5.0
· Max. Chlorine Concentration	< 0.1 mg/L

The information provided in this document is solely for informative purposes. It is the user's responsibility to ensure the appropriate usage of this product. Woongjin Chemical assumes no obligation, liability or damages incurred for the misuse of the product or for the information provided in this document. This document does not express or implies any warranty as to the merchantability or fitness of the product.

GENERAL HANDLING PROCEDURES

- Elements contained in the boxes must be kept dry at room temperature (7–32°C; 40–95°F) and should not be stored in direct sunlight. If the polyethylene bag is damaged, a new preservative solution (sodium bisulfite) must be added and air-tight sealed to prevent drying and biological growth.
- Permeate from the first hour of operation should be discarded to flush out the preservative solution.
- Elements should be immersed in a preservative solution during storage, shipping and system shutdowns to prevent biological growth and freezing. The standard storage solution contains 1% by weight sodium bisulfite or sodium metabisulfite (food grade). For short term storage (i.e. one week or less) 1% by weight sodium metabisulfite solution is adequate for preventing biological growth.
- Keep elements moist at all times after initial wetting.
- Only use chemicals compatible with the membrane elements and components. Use of such chemicals may void the element limited warranty.
- Permeate pressure must always be equal or less than the feed/concentrate pressure. Damage caused by permeate back pressure voids the element limited warranty.

REF.	OLD REF.	MODEL NAME	
		RE2010-LP	
MCRE2012-LP	DA054	RE2012-LP	
MCRE2012-LPF	DA055	RE2012-LPF	



RESIDENTIAL

Tankless RO elements for residential use

CSM®

SPECIFICATIONS:

General Features

Model Name	Permeate Flow Rate GPD (L/day)	Salt Rejection (%)
RE35 I2-TK	600 (2,271)	95.0

1. The stated product performance is based on data taken after 30 minutes of operation at the following test conditions:

- 200 mg/L NaCl solution at 60 psig (0.41 MPa) applied pressure
- 30% recovery
- 77 °F (25 °C)
- pH 6.5–7.0

2. Minimum salt rejection is 93.0%.

3. Dry type elements are vacuum leak tested using the CSM integrity test.

4. Permeate flow rate for each element may vary but will be no more than 15%.

5. Dry elements are packaged in a polyethylene bag.

Membrane type:	Thin-Film Composite
Membrane material:	Polyamide (PA)
Element configuration:	Spiral-Wound, Tape Wrapping

Dimensions

Model Name	A	B	C	D	E
RE35 I2-TK	0.67 (17)	0.31 (8)	11.73 (298)	0.63 (16)	3.35 (85)

*All measurements are in inches (millimeters).





RESIDENTIAL

Tankless RO elements for residential use

CSM[®]

APPLICATION DATA:

Operating Limits

· Max. Operating Pressure	150 psi (1.03 MPa)
· Max. Feed Flow Rate	5 gpm (1.14 m ³ /hr)
· Max. Operating Temperature	113 °F (45 °C)
· Operating pH Range	2.0–11.0
· Max. Turbidity	1.0 NTU
· Max. SDI (15 min)	5.0
· Max. Chlorine Concentration	< 0.1 mg/L

The information provided in this document is solely for informative purposes. It is the user's responsibility to ensure the appropriate usage of this product. Toray Chemical Korea Inc. assumes no obligation, liability or damages incurred for the misuse of the product or for the information provided in this document. This document does not express or implies any warranty as to the merchantability or fitness of the product.

GENERAL HANDLING PROCEDURES

- Elements contained in the boxes must be kept dry at room temperature (7–32°C; 40–95°F) and should not be stored in direct sunlight.
- When running the system for the first time, the permeate should be discarded continuously at least 1 hour.
- Keep elements moistly at all times after initial wetting.
- Elements should be immersed in a preservative solution during storage, shipping and system shutdowns to prevent biological growth and freezing. The standard storage solution contains 1% by weight sodium bisulfite or sodium metabisulfite (food grade). For short term storage (i.e. one week or less) 1% by weight sodium metabisulfite solution is adequate for preventing from biological growth.
- Only use chemicals compatible with the membrane elements and components. Use of such chemicals may void the element limited warranty. For additional information on use of approved chemicals please contact your nearest CSM representative.
- Permeate pressure must always be equal or less than the feed/concentrate pressure. Damage caused by permeate back pressure voids the element limited warranty.

REF.	OLD REF.	MODEL NAME	
MCRE3512-TK	DB031	RE3512-TK	

1,8" - 2" Residential CSM Membranes



RESIDENTIAL

NF elements for residential use

CSM®

SPECIFICATIONS:

General Features

Model Name	Permeate Flow Rate GPD (L/day)	Salt Rejection %
NE1812	80 (379)	40.0–60.0%
NE2010	90 (341)	40.0–60.0%

- The stated product performance is based on data taken after 30 minutes of operation at the following test conditions:
 - 250 mg/L NaCl solution at 60 psig (4.14 MPa) applied pressure
 - 15% recovery
 - 77 °F (25 °C)
 - pH 6.5–7.0
- Dry type elements are vacuum leak tested using the San Diego Protocol.
- Permeate flow rate for each element may vary but will be no more than 15%.
- All elements are packaged in a polyethylene bag containing 1.0% SBS (sodium bisulfite) solution.

Membrane type: Thin-Film Composite
Membrane material: Polyamide (PA)
Element configuration: Spiral-Wound, Tape Wrapping

Dimensions

Model Name	A	B	C	D	E
NE1812	0.67	0.87	11.73	0.87	1.77
NE2010	0.67	0.63	10.08	0.87	1.91

*All measurement are in inches



1,8" - 2" Residential CSM Membranes



RESIDENTIAL

NF elements for residential use

CSM[®]

APPLICATION DATA:

Operating Limits

· Max. Operating Pressure	125 psi (0.86 MPa)
· Max. Feed Flow Rate	2 gpm (0.45 m ³ /hr)
· Max. Operating Temperature	113 °F (45 °C)
· Operating pH Range	2.0–11.0
· Max. Turbidity	1.0 NTU
· Max. SDI (15 min)	5.0
· Max. Chlorine Concentration	< 0.1 mg/L

The information provided in this document is solely for informative purposes. It is the user's responsibility to ensure the appropriate usage of this product. Woongjin Chemical assumes no obligation, liability or damages incurred for the misuse of the product or for the information provided in this document. This document does not express or implies any warranty as to the merchantability or fitness of the product.

GENERAL HANDLING PROCEDURES

- Elements contained in the boxes must be kept dry at room temperature (7–32°C; 40–95°F) and should not be stored in direct sunlight. If the polyethylene bag is damaged, a new preservative solution (sodium bisulfite) must be added and air-tight sealed to prevent drying and biological growth.
- Permeate from the first hour of operation should be discarded to flush out the preservative solution.
- Elements should be immersed in a preservative solution during storage, shipping and system shutdowns to prevent biological growth and freezing. The standard storage solution contains 1% by weight sodium bisulfite or sodium metabisulfite (food grade). For short term storage (i.e. one week or less) 1% by weight sodium metabisulfite solution is adequate for preventing biological growth.
- Keep elements moist at all times after initial wetting.
- Only use chemicals compatible with the membrane elements and components. Use of such chemicals may void the element limited warranty.
- Permeate pressure must always be equal or less than the feed/concentrate pressure. Damage caused by permeate back pressure voids the element limited warranty.

REF.	OLD REF.	MODEL NAME	
MCNE1812	DA060	NE1812	
		NE2010	

1,8" - 2" Residential CSM Membranes



RESIDENTIAL

UF elements for residential use

CSM[®]

SPECIFICATIONS:

General Features

Model Name	Permeate Flow Rate GPD (L/day)	Molecular Weight Cut Off
UE1810	200 (757)	100K
UE1812	250 (946)	100K
UE2010	450 (1,703)	100K

1. The stated product performance is based on data taken after 30 minutes of operation at the following test conditions:

- Pure water (2 MΩ) at 20 psig applied pressure
- 100% recovery
- 77 °F (25 °C)

2. Dry type elements are vacuum leak tested using the San Diego Protocol.

3. Permeate flow rate for each element may vary but will be no more than 15%.

4. Dry elements are packaged in a polyethylene bag

α Wet elements are packaged in a polyethylene bag containing SB(4g/L) + HCl(0.51g/L) solution.

Membrane type: Thin-Film Composite
Membrane material: Polysulfone (PSF)
Element configuration: Spiral-Wound, Tape Wrapping

Dimensions

Model Name	A	B	C	D	E
UE1810	0.67	0.55	10.08	0.98	1.77
UE1812	0.67	0.55	11.02	0.79	1.77
UE2010	0.67	0.55	10.08	0.98	1.91

*All measurement are in inches

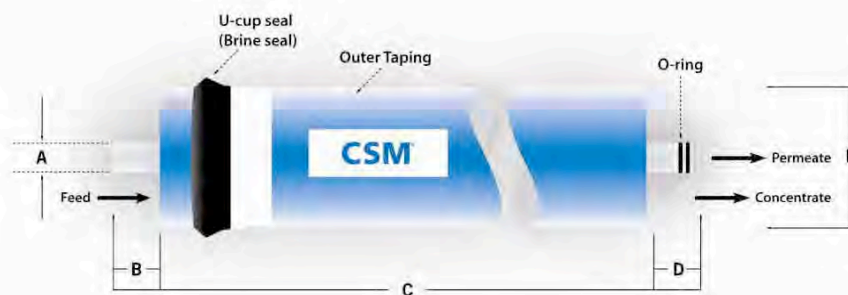

These model names are tested and certified under NSF/ANSI standard 58, material requirement only (excluding UE1812)

1,8" - 2" Residential CSM Membranes



RESIDENTIAL

UF elements for residential use

CSM®

APPLICATION DATA:

Operating Limits

· Max. Operating Pressure	125 psi (0.86 MPa)
· Max. Feed Flow Rate	2 gpm (0.45 m ³ /hr)
· Max. Operating Temperature	113 °F (45 °C)
· Operating pH Range	2.0–11.0
· Max. Turbidity	1.0 NTU
· Max. SDI (15 min)	5.0

The information provided in this document is solely for informative purposes. It is the user's responsibility to ensure the appropriate usage of this product. Woongjin Chemical assumes no obligation, liability or damages incurred for the misuse of the product or for the information provided in this document. This document does not express or imply any warranty as to the merchantability or fitness of the product.

GENERAL HANDLING PROCEDURES

- Elements contained in the boxes must be kept dry at room temperature (7–32°C; 40–95°F) and should not be stored in direct sunlight. If the polyethylene bag is damaged, a new preservative solution (sodium bisulfite) must be added and air-tight sealed to prevent drying and biological growth.
- Permeate from the first hour of operation should be discarded to flush out the preservative solution.
- Elements should be immersed in a preservative solution during storage, shipping and system shutdowns to prevent biological growth and freezing. The standard storage solution contains 1% by weight sodium bisulfite or sodium metabisulfite (food grade). For short term storage (i.e. one week or less) 1% by weight sodium metabisulfite solution is adequate for preventing biological growth.
- Keep elements moist at all times after initial wetting.
- Only use chemicals compatible with the membrane elements and components. Use of such chemicals may void the element limited warranty.
- Permeate pressure must always be equal or less than the feed/concentrate pressure. Damage caused by permeate back pressure voids the element limited warranty.

REF.	OLD REF.	MODEL NAME	
		UE1810	
MCUE1812	DA065	UE1812	
		UE2010	

Vessel for Residential Elements



1,8" - 2" membranes

- material PP white;
- connections 1/8" NPT F;
- max pressure 125 psi (8,6 bar);
- double o-ring;
- permeate tube seat diameter = 0,67";
- nominal dimension 1812 - 2012.

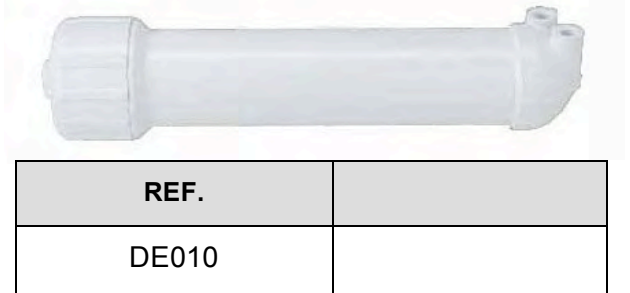

Membranes coupling:

- CSM 1,8" - 2" residential membranes, see 10-01-01-EN, 10-01-02-EN, 10-01-03-EN, 10-01-04-EN and 10-01-05-EN data sheets.

Single mounting clips for vessel residential 1,8" - 2" membranes

- material PP;
- white colour.

REF.	
DE034	



2,8" - 3" membranes

- material PP white;
- connections:
 - feed, permeate and concentrate 3/8" NPT F (please, use our fittings ref. AV153 or elbows ref. AV159);
- max pressure 125 psi (8,6 bar);
- permeate tube seat diameter = 0,67";
- nominal dimension 2812 - 3012.



Membranes coupling:

- CSM 2,8" residential membranes, see 10-01-02-EN data sheet.

Single mounting clips for vessel residential 2,8" - 3" membranes

- material PP;
- white colour.

REF.	
DE006	



In-Line Cartridges



- IN LINE cartridges ¼" NPT F connections;
- Max pressure = 100 psi (7 bar);
- Max temperature = 35°C;
- D.M. n.174 dated 06/04/2004 compliant about materials suitable for contact with water for human consumption.

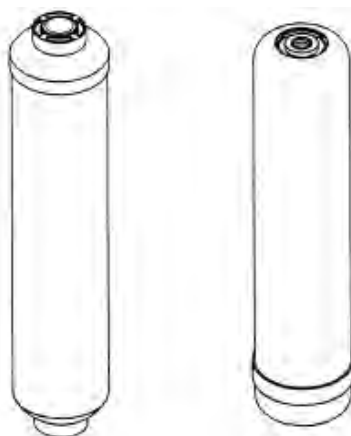

REF.	DIAMETER (inch)	LENGTH (inch)	VERSION	FLOW (gpm)	
DE028	2"	10"	Coconut Shell Activated Carbon	0,75	
DE029	2"	10"	Sediment	0,75	
DE030	2 ½"	11"	Coconut Shell Activated Carbon	1,00	
DE031	2 ½"	11"	Sediment	1,00	

R.O. compact assembly and accessories

REF.	DESCRIPTION	
DE100	Compact assembly empty	
DE101	Special membrane 50 GPD	
DE102A	Sediment / Carbon Block Prefilter cartridge	
DE103	GAC Postfilter cartridge	

(* available till it will be out-of-stock.

Permeate Pump for Residential R.O. Systems



- using the energy of the brine water of the R.O. system to pump the permeate into the pressure tank, increases the net operating pressure on the membrane and eliminate the negative effect of the pressure on the storage tank;
- hydraulic pump, does not require electricity;
- for residential R.O. systems with pressurized storage tank and membrane from 35 to 100 GPD;
- the permeate pump can increase up to 5 time the system recovery, reducing the water consumption and the refill time of the storage tank;
- no shut-off valve is needed;
- materials polypropylene/ EPDM;
- max operating pressure 6,8 bar;
- connections for 1/4" tubing;
- max drain flow rate 0,8 l/min.

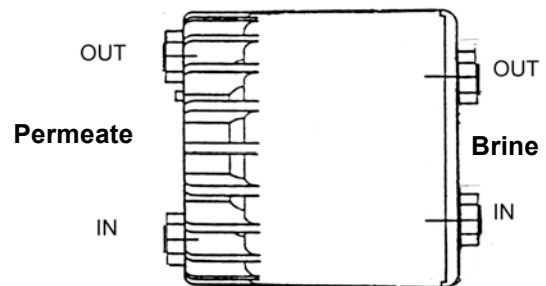

REF.	
DE120	

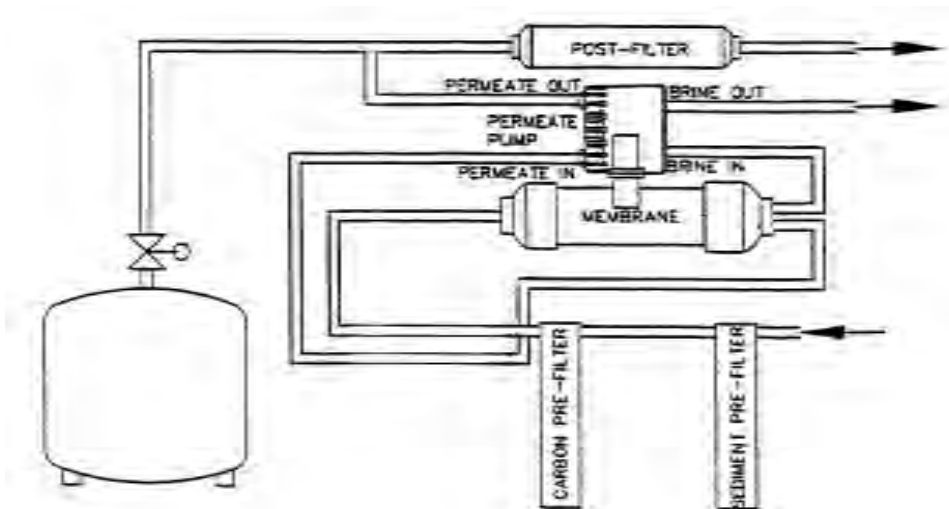

Typical system layout **ATTENTION**

Install the pump horizontal with both outlet ports in the highest position so that any air purges out automatically.

The concentrate flow restrictor has to be installed before the permeate pump inlet.

ACCESSORIE		
REF.	DESCRIPTION	
DE121	SINGLE MOUNTING CLIP	

Booster Pump for Residential R.O.



- booster pump and relevant accessories for residential R.O. Systems.
- membrane booster pump with transformer;
- transformer power supply 220 V – 50 Hz;
- IN/OUT connections 3/8" F.

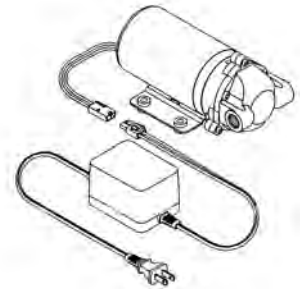

REF.	MODEL	POWER SUPPLY	FLOW (liters/min)	
			60 psi	100 psi
DE130	E36	24 VAC	0,8	0,6

Accessories:

High/low pressure switch

- pressure 30 – 50 psi;
- connections 1/4" tube.

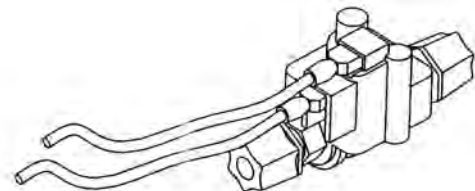

REF.	
DE140	

- to use as high pressure switch contacts C and NC;
- to use as low pressure switch contacts C and NO.

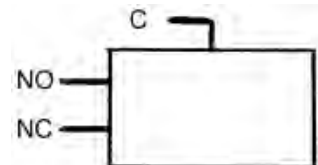

Typical system layout

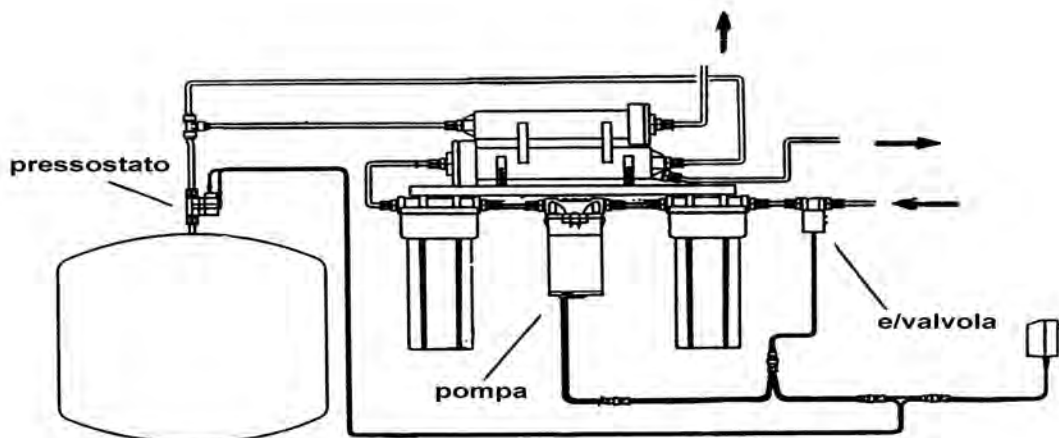

Two-Way Solenoid Valves for R.O. Systems



- two-way solenoid valve direct acting;
- body material plastic;
- connections 1/4" NPT;
- power supply 24 VAC;
- orifice diameter 2,5 mm.



REF.	
DE142	

- two-way solenoid valve direct acting;
- body material brass.



Ref. DE144



Ref. DE147

REF.	CONNECTIONS (inch)	POWER SUPPLY	ORIFICE DIAMETER (mm)	
DE144	1/4"	24 VDC	3,0	
DE147	3/8"	220 VAC	4,5	



Saddle Valve

- saddle valve self piercing for residential R.O and filtration systems;
- suitable for copper piping;
- connection for 1/4" tubing;
- material brass with aluminium clamp.

REF.	
DE041	



Needle Valves

- needle valve for residential R.O and filtration systems;
- for tube 1/2" M/F or 3/8" M/F;
- connection for 1/4" or 3/8" or 5/16" flexible tubing;
- material brass.



REF.	TUBE (inch)	FLEXIBLE TUBING (inch)	
DE039	1/2" M/F	1/4"	
DE050	1/2" M/F	3/8"	
DE050A	1/2" M/F	5/16"	
DE039A	3/8" M/F	1/4"	

Drain and Diverter Valves for R.O. Systems



- suitable for residential R.O and filtration systems.

Drain Clamp

- material ABS black.

REF.	CONNECTION (inch)	
DE040	¼" tubo	
DE049	¼" F NPT	



Diverter Valve with Swivel Collar

- connection for ¼" tubing;
- material chrome plated brass.

REF.	
DE042	



ADAPTER 15/16" – 27 X 55/64" – 27

- length 8 mm;
- material chrome plated brass.

REF.	
DE043	



Jaco Style Fittings



- Range of polypropylene fittings, white colour, for residential R.O. and filtration systems.

STRAIGHT			
REF.	THREADED CONNECTION (inch)	FOR TUBE (inch)	
DE063	1/8"	1/4"	
DE064	1/4"	1/4"	
DE068	1/4" F	1/4"	
DE069	3/8"	1/4"	

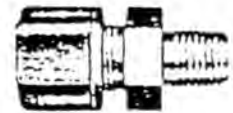

ELBOWS			
REF.	THREADED CONNECTION (inch)	FOR TUBE (inch)	
DE060	1/8"	1/4"	
DE062	1/8" F	1/4"	
DE061	1/4"	1/4"	
DE070	3/8"	1/4"	



TEES				
REF.	1/4" THREAD POSITION	THREADED CONNECTION (inch)	FOR TUBE (inch)	
DE065	LATERAL	1/4"	1/4"	
DE066	CENTRAL	1/4"	1/4"	
DE067	-	-	1/4"	

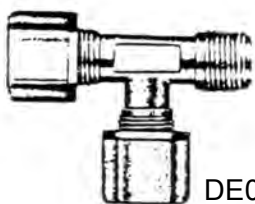

DE065

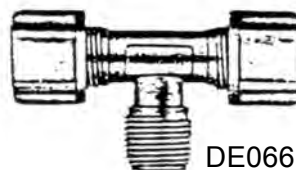

DE066



DE067

BULKHEAD UNION		
REF.	FOR TUBE (inch)	
DE085	1/4"	





In-Line Flow Restrictors

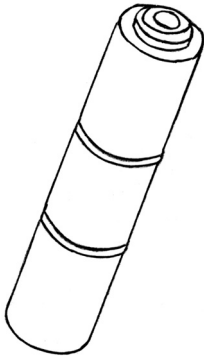

- Quick connections 1/4" tube.

REF.	Flow @ 60 psi (gpd)	Flow @ 60 psi (ml/min)	
DE105	60	150	
DE106	115	300	
DE107	150	400	
DE108	208	550	
DE109	227	600	
DE110	300	800	

JACO Style Check Valve

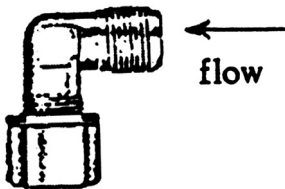

- Jaco style elbow 1/8" x 1/4" tube complete with AISI check-valve.

REF.	
DE079	

S.S. Check Valve

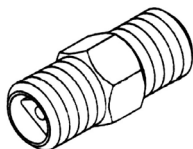

- Stainless steel check valve 1/8" x 1/8".

REF.	
DE048	



PP Storage Tanks

- pressurized storage tank for treated water;
- white colour;
- connection 1/4" NPT;
- min. operating pressure 1 bar.



REF.	CAPACITY (liters)	MATERIAL	DIAMETER (mm)	HEIGHT (mm)	MAX PRESSURE (bar)	
DE032	12	PP / acciaio	240	370	7,0	
DE051	15	PP	260	400	3,5	

Steel Storage Tanks

- pressurized storage tank for R.O water;
- material painted steel, white colour;
- connection 1" BSPP female;
- with threaded extension M 1" x 1/4", with elbowed ball valve with connection 3/8" tubing;
- min. operating pressure 1 bar;
- max operating pressure 7 bar.



REF.	CAPACITY (liters)	DIAMETER (mm)	HEIGHT (mm)	
DE096	41	390	575	
DE097	75	390	770	



Elbowed Ball Valve

- material white plastic;
- connections 1/4" F NPT x 1/4" tubing.

REF.	
DE052	



Automatic Shut-Off Valve

- material white ABS;
- connections 1/4" tubing;
- max pressure 125 psi (8,5 bar).

REF.	
DE038	

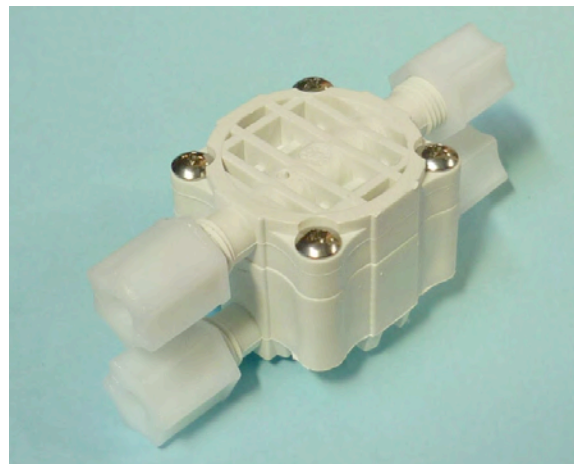

Mechanical Flow Meter

- adjustable setting;
- automatic shut-off based on volume;
- capacity 7000 litres;
- connections 1/4" NPT;
- operating pressure 1 ÷ 8,5 bar;
- material ABS, black colour.

REF.	
DE080	





Single Mounting Clips

- PP material;
- white colour.

REF.	DIAMETER (inch)	DIAMETER (mm)	
DE033	2"	50	
DE034	2 1/2"	60	
DE006	3"	90	



Double Mounting Clips

- PP material;
- white colour.

REF.	DIAMETER (inch)	DIAMETER (mm)	
DE035	2" x 2 1/2"	50 x 60	
DE036	2 1/2" x 2 1/2"	60 x 60	



Flexible 1/4" Tubing

- hanks of 50 m (100 m only for DE081).

REF.	DIAMETER (inch)	DIAMETER (mm)	
DE082	PVC	White	
DE083	PE	Blue	
DE084	PE	Black	
DE086	PE	Red	
DE081	PE	Clear	



Needle Valve In-Line Style

- brass material

REF.	TUBE CONNECTIONS	
DE098	1/4"	
DE098A	3/8"	



Insert for Flexible 1/4" Tubing

- CELCON material

REF.	
DE059	





Long Reach Faucet

- material chrome plated;
- connection for ¼" tubing;
- complete with installation kit;
- threaded tube length 50 mm.

REF.	
DE037	

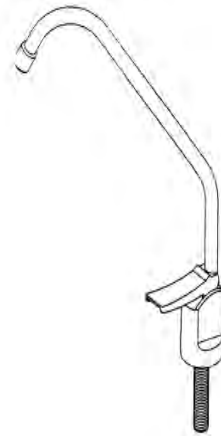

Quarter-Turn faucet

- metal and plastic chrome material;
- connection for ¼" tubing;
- complete with installation kit;
- threaded tube length 71 mm;
- wetted materials suitable for drinking water use;
- conform to the requirements of NSF/ANSI 61.

REF.	
DE116	



Single Handle Faucet with Drinking Nozzle

- monobloc, material chrome plated;
- adjustable necks;
- hot and cold water connections ½" with needle valves;
- treated water connection ¼" tube;
- complete with installation kit.

REF.	
DE087	

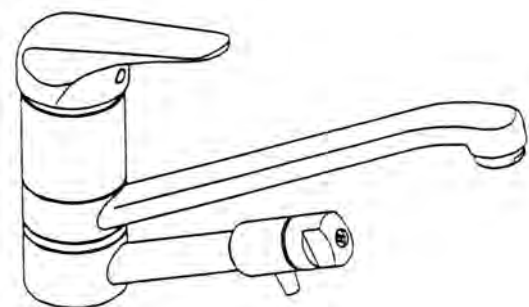



Pressure Gauge

- pressure set 0 ÷ 10 bar;
- connection 1/8" M;
- diameter 25 mm.

REF.	
DE077	



3 Ways Adapter for Pressure Gauge

- plastic material;
- connections 1/8" F x 1/8" M x 1/4" tube.

REF.	
DE078	



In Line Needle Valve

- plastic material;
- 1/4" tube quick connections.

REF.	
DE088	



Check Valve in Line

- plastic material;
- 1/4" tube quick connections.

REF.	
DE089	



Filter Housings for R.O. Systems



- suitable for residential R.O. and filtration systems;
- two pieces filter housing with fixable head;
- plastic material;
- IN-OUT connections 1/4" NPT;
- max operating pressure 7 bar;
- max operating temperature 35°C.



REF.	MODEL	LENGTH CARTRIDGE (inch)	SUMP MATERIAL AND COLOUR
DE020	AS 0514	5"	AS clear
DE021A	PP 1014	9 3/4"	PP white
DE016	AS 1014	9 3/4"	AS clear

Accessories

REF.	DESCRIPTION
FB004	PLASTIC WRENCH WHITE COLOUR

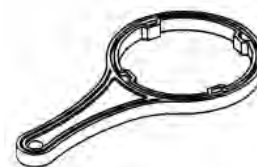

REF.	DESCRIPTION
DE019	PP 1/4" X 1/4" NIPPLE, LENGTH 38 mm, WHITE COLOUR



REF.	DESCRIPTION
FB007	BRACKET FOR SINGLE FILTER, MATERIAL WHITE COATED METAL

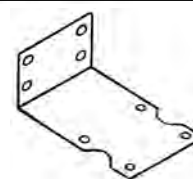

REF.	DESCRIPTION
DE025	BRACKET FOR DOUBLE FILTER, MATERIAL WHITE COATED METAL

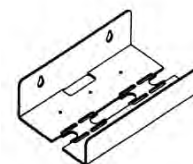

REF.	DESCRIPTION
DE026	BRACKET FOR TRIPLE FILTER, MATERIAL WHITE COATED METAL

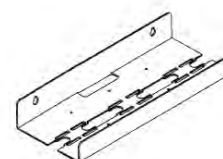

Flow Restrictor Linear Type



- capillary adjusting flow system with insertion in tube 1/4" diameter ($\varnothing=6,35$ mm);
- 200 mm standard length; you can change the length as required (please see the diagram below);
- PP material insert: PE material capillary tube;
- range of operating pressure 2 ÷ 8 bar.

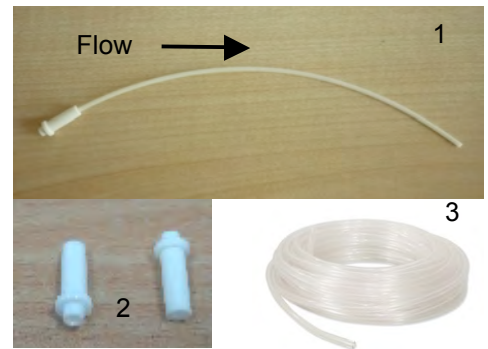

ITEM	DESCRIPTION	REF.	
1	FLOW RESTRICTOR LINEAR TYPE; L = 200 MM	DE122	
2	FLOW RESTRICTOR FRT-14P INSERT	DE124	
3	CAPILLARY TUBE (25 M ROLL)	DE125	
4	FLOW RESTRICTOR JACO DOUBLE INSERT OPEN	DE123	

WARNING: it is essential that the cutting of the capillary be net and tube perfectly circular (you can use an awl in order to restore the circular form), otherwise the flow rate value can be greatly altered. Observe the flow direction as shown in Picture n.1.

Flow restrictor linear type

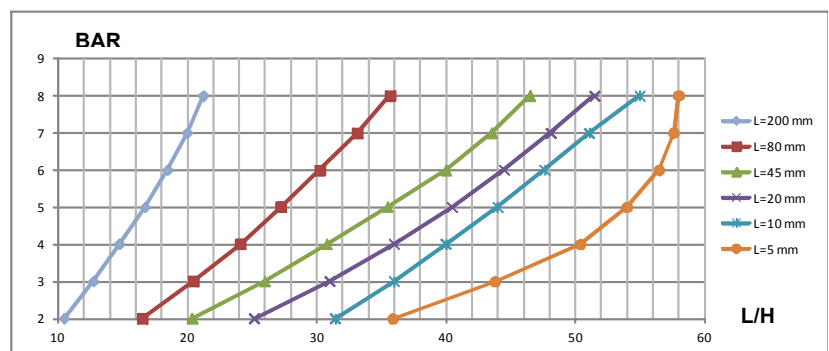

Flow restrictor Jaco 1/4" double insert open

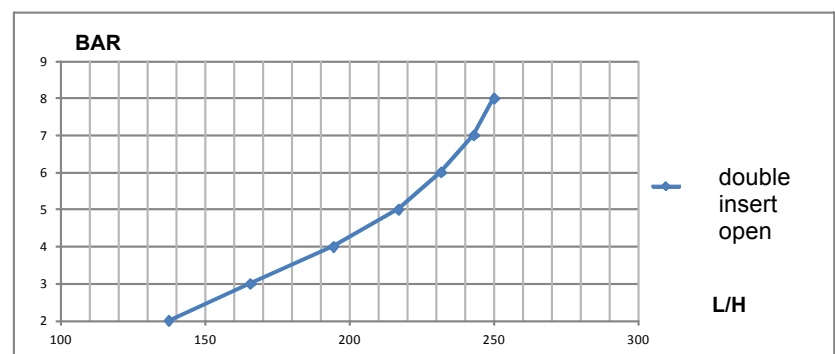

PRF-RO Reverse Osmosis System



- Suitable for residential and commercial application use;
- Compact and reliable system that better suits the flow requirements of small and mid-sized businesses;
- No storage tank needed;
- Works with Line Pressure;
- No Pump or Electricity;
- Very easy installation with quick connections;
- Virtually Maintenance Free (change cartridges fast and easy);
- Consisting of Nr.1 Carbon Pre-Filter, Nr.2 R.O. Membrane Elements and Nr.1 Carbon Post-Filter.



OPERATING CONDITIONS	MINIMUM	MAXIMUM
Inlet Pressure	2,8 bar (40 psi)	5,5 bar (80 psi)
Inlet Temperature (°C)	4	38
Inlet TDS (mg/l)	50	2.000
Inlet Hardness (°F)	0	20
Inlet Chlorine (mg/l)	0	1,0
Inlet Iron (mg/l)	0	0,1
Inlet Manganese (mg/l)	0	0,05

Salt Rejection: Minimum 90%, Medium 93%.

TUBING/FITTING DIMENSIONS	
Inlet Tubing (natural tubing)	1/2"
Concentrate Tubing (black tubing)	3/8"
Permeate Tubing (blue tubing)	3/8"
Drain Tubing (red tubing) for airgap installation	1/2"
Drain connection	3/8" or 1/2"
Carbon Post-Filter	3/8" quick disconnect fittings

Filter/Membrane Performance Specifications:

Filter Type	Length (mm)	Diameter (mm)	Flow Rate (lpm)	Flow Rate (gpm)	Average Life (months)
Carbon Pre-Filter	432	74	14,20	3,75	6 (or 19.000 liters)
RO Element	476	80	(*) 0,95	(*) 0,25	24 ÷ 48
Carbon Post-Filter	254	51	2,80	0,75	6 (or 19.000 liters)

(*) @ 3,44 bar T=25°C 750 mg/l NaCl 25% recovery 1 ppm Chlorine inlet

Ref.	P. N.	Description
DE904	4000462	Kit R.O. PRF-RO System with faucet
DE906	4000575	Kit R.O. PRF-RO System without faucet

PRF-RO Reverse Osmosis System



Outline Dimensions in Inches (mm):

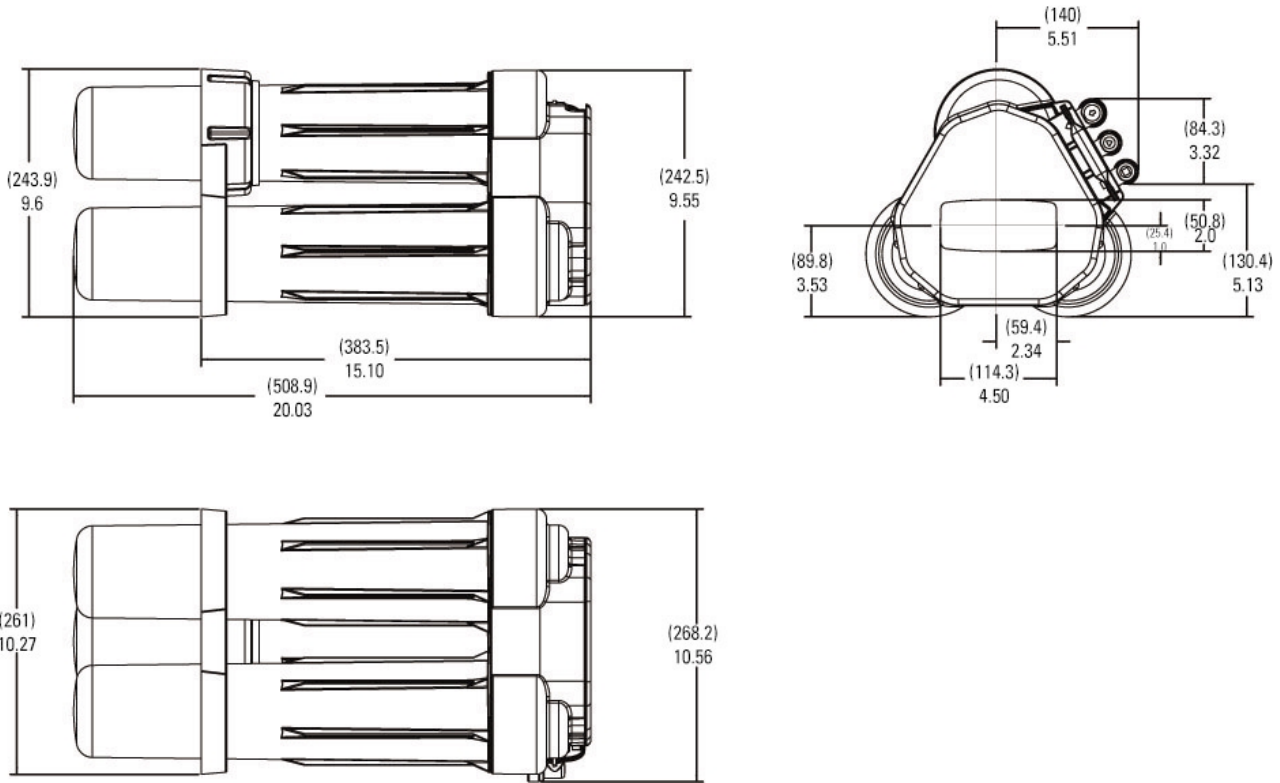

Performance – Flow Rate Characteristics (*)

Based on 750 ppm TDS Inlet Water

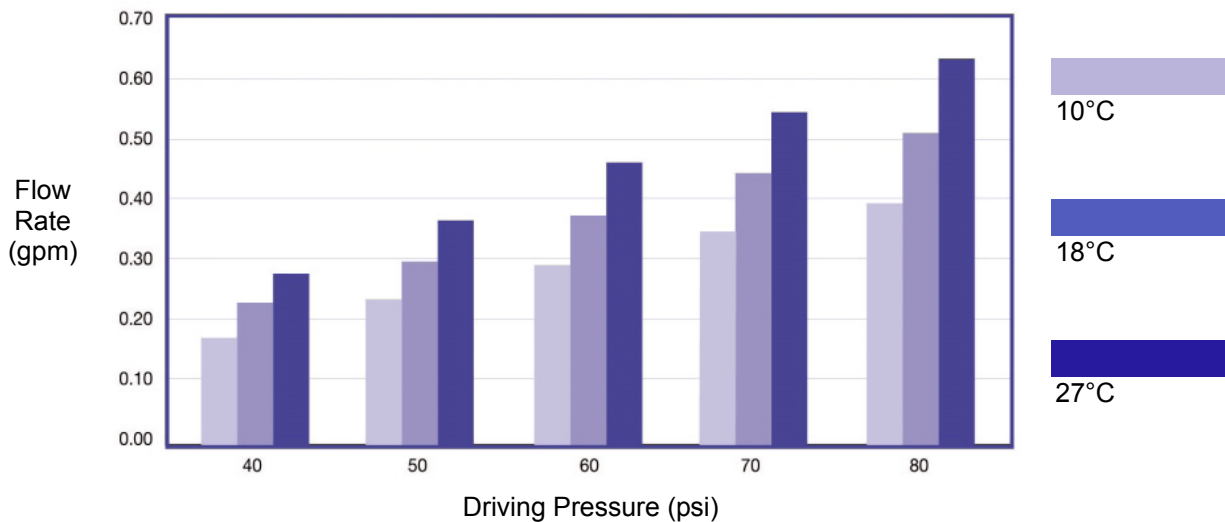

Flow Adjustment Based on TDS

(*) Estimated flow based on internal test data. Actual performance may vary.

PRF-RO Reverse Osmosis System



Spare parts of PRF-RO Reverse Osmosis System:

Ref.	P. N.	Description	
DE920	4000569	PRF-RO Membrane	
DE923	3038333	Carbon pre-filter	
DE924	1266690	Sediment pre-filter 10 micron	
DE926	255526-09	Carbon post-filter	
DE930	1239705	Sump	
DE932	1240326	Sump o-ring	
DE935	4000445	PRF-RO complete manifold	
DE937	3038021	PRF-RO Support Leg	
DE938	1240564	Drain boa kit	
DE941	3038026	Locking bar disconnect	
DE942	3020487	Air-gap faucet kit	
DE945	4000330	PRF-RO kit connection fittings	
DE946	1255736	Tubing install kit	
DE950	1240620	3/8" black tubing 152 m	
DE951	1240621	3/8" blue tubing 152 m	
DE952	1240622	1/2" natural tubing 76 m	
DE953	1240623	1/2" red tubing 76 m	
DE954	1264462	Fitting elbow concentrate 3/8" black	
DE955	12400117	Fitting elbow feed 1/2" white	
DE956	12400118	Fitting elbow permeate 3/8" blue	
DE960	3002791	Tds and temperature meter	
DE961	4000454	PRF-RO retro fit kit	

GENERAL SALE'S CONDITIONS

- Any other conditions different from the following will be valid, if accepted in writing.
- Sending the order, the Buyer knows and accepts the general sale's conditions.
- The prices are ex-warehouse, packing included.
- Catalogs and technical sheets can be modified in any moment.
- Eventual delays in delivery do not justify the order's cancellation neither any indenisation.
- Any risk during the delivery is taken by the Buyer. The Buyer has to check quantities and conditions at the reception of the goods; eventual complaints have to be made in writing within 8 days from reception.
- The products are guaranteed for a period of 12 months from the date of delivery, except the normal wear.
The goods considered defective, after our written authorization, have to be returned at Buyer's freight together with the information about the defect.
- We can accept return of material for any different reason than warranty claim only by previous authorization and within 90 days from invoice date. The value of goods will be decreased by 20% from purchase price for all the products except for cabinets that will be decreased by 30%.
- In case of delay in payments interest are due. The delay will cause the suspension of the guarantee and further supplies. The property of the delivered goods will remain to us until the complete payment of the invoices.
- We will not accept orders for net amount lower than 250 EURO.
- In case of controversy the Law – court of Milan (Italy) will be competent.



EUROTROL  [®]
WATER TREATMENT COMPONENTS

Eurotrol S.p.A.
Via Enrico Fermi, 23
20019 Settimo M.se (MI) - ITALY
Tel +39.02.335458 r.a.
Fax +39.02.33545814
e-mail: eurotrol@eurotrol.it
web: www.eurotrol.it